

RØDE[®]
MICROPHONES



STEREO VIDEOMIC PRO

INSTRUCTION MANUAL



www.rodemic.com



INTRODUCTION

Thank you for investing in the RØDE Stereo VideoMic Pro.

The Stereo VideoMic Pro boasts an impressive lineage as RØDE's latest addition to our celebrated on-camera microphone range. The now legendary RØDE VideoMic was released in 2004 during the MiniDV camera boom, the only microphone of its kind in a market that only offered either cheap inferior quality or high cost shotgun microphones which were not designed to integrate easily with the cameras.

RØDE has now been bridging this gap for years by providing microphones which feature broadcast audio quality and integrated shock mounting while maintaining an accessible price tag. The VideoMic has gone on to become the world's largest selling microphone for consumer cameras.

As innovative new video cameras are designed with increasing rapidity, we know the audio devices that match them must also adapt and grow with the technology. The Stereo VideoMic Pro has been designed for ambient audio recording with the latest consumer and prosumer cameras; incorporating remarkable stereo imaging and a more intuitive and resilient shock mounting system than ever before. Of course, the form factor has also been updated to a conveniently compact size, which is perfect for videographers who prefer wide angle lenses.

Please take the time to visit www.rodemic.com and register your microphone for a full ten year warranty.



Peter Freedman
RØDE Microphones
Sydney, Australia

CONTENTS

INTRODUCTION	2.
SPECIFICATIONS	3.
FEATURES	4.
WHAT'S IN THE BOX	4.
STEREO VIDEOMIC PRO STRUCTURE	5.
SETUP AND USE	
Installing the battery	6.
Mounting and connecting	7.
Stereo VideoMic Pro controls	8.
Replacing shock mount bands	10.
OPTIONAL ACCESSORIES	13.
SAFETY / CARE INSTRUCTIONS	15.
TROUBLESHOOTING / FAQ	16.
PRODUCT WARRANTY	18.
SUPPORT AND SERVICE	18.

SPECIFICATIONS

Acoustic Principle:	Pressure gradient
Frequency Range:	40 Hz ~ 20,000 Hz
Frequency Range: (High Pass Filter)	Selectable HPF @ 75 Hz / -10 dB /octave
Output impedance:	200Ω
Signal to Noise Ratio:	76 dBA
Equivalent Noise:	18 dBA SPL (as per IEC651)
Maximum SPL:	134 dB SPL
Maximum output:	4.2 dBu (@ 1kHz, 1% THD into 1K Ω load)
Sensitivity:	-38 dB re 1V/Pa (12.60 mV @ 94 dB SPL) ± 2 dB @ 1kHz
Dynamic Range:	102 dB SPL
Power requirements:	9 Volt/PP3
Output Connection:	3.5 Stereo mini jack Tip – left channel Ring – right channel
Battery Life:	Over 100 hours (alkaline) Over 10 hours on low battery life
Weight:	115g (0.253lb) without battery Packed weight: 240g (0.529lb)
Dimension (W x L x H):	66.0mm × 108.0mm × 130.0 mm (2.598in × 4.251in × 5.118in)

FREQUENCY RESPONSE

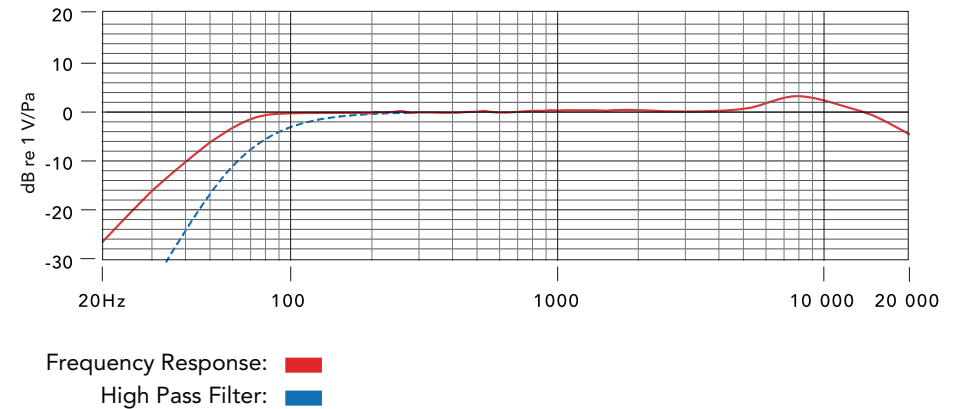

POLAR PATTERN

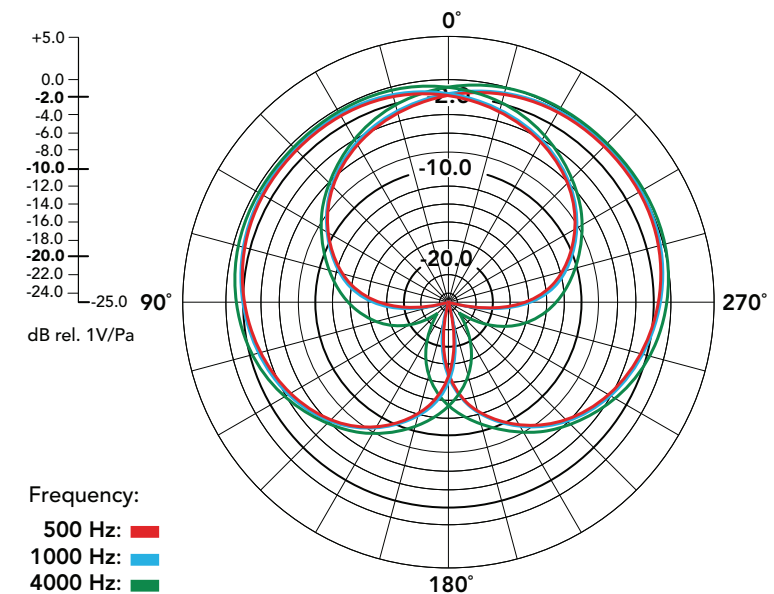

FEATURES

WHAT'S IN THE BOX

STEREO ON-CAMERA MICROPHONE

- X/Y Stereo recording configuration
- Broadcast recording quality
- Compact, lightweight body
- Integrated shock mount provides isolation from handling / mechanical noise
- Integrated foam windshield
- 3.5mm stereo mini jack output

DETAILED CONTROL

- Two step high-pass filter (0, 75 Hz)
- Three position level control (-10dB, 0dB, +20dB)
- LED on / off power indicator
- Integrated billeted metal camera shoe mount with 3/8" thread for easy boompole mounting

HIGH QUALITY PERFORMANCE

- 9V battery powered – over 100 hours use (alkaline)
- RF/EMI shielded cable and electronics for extremely low radio interference
- Low noise circuitry
- Australian designed and manufactured



- Stereo VideoMic Pro
- Spare shock mount bands (4 pieces)
- Stereo VideoMic Pro quick start guide
- Moisture absorbent crystals

STEREO VIDEOMIC PRO STRUCTURE

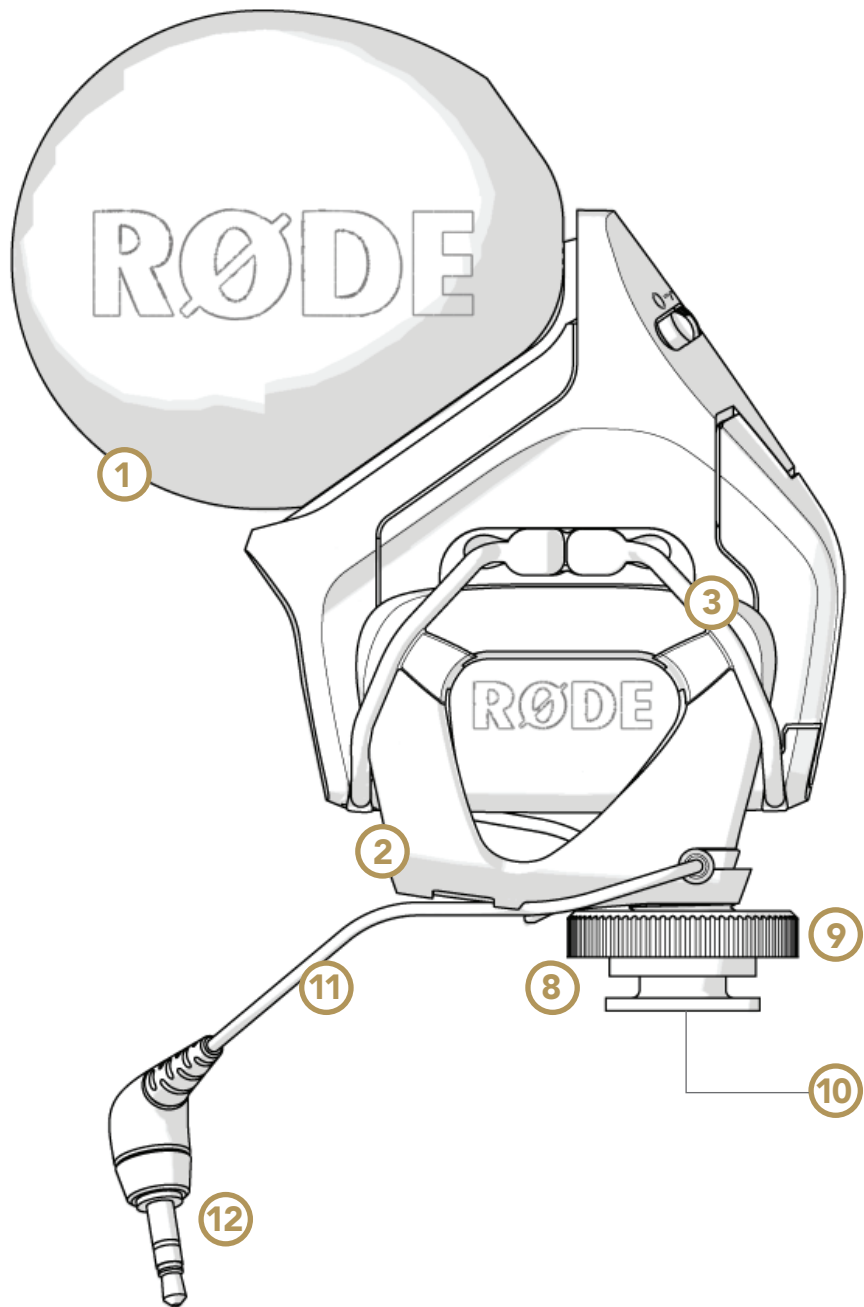

1. Foam windshield
2. Shock mount cradle
3. Shock mount band
4. Power / High Pass Filter switch
5. Level attenuation / boost switch
6. Power on / off LED indicator
7. Battery cover
8. Billeted metal camera shoe mount
9. Fastening ring
10. 3/8" thread mount
11. Signal output cable
12. 3.5mm stereo mini jack

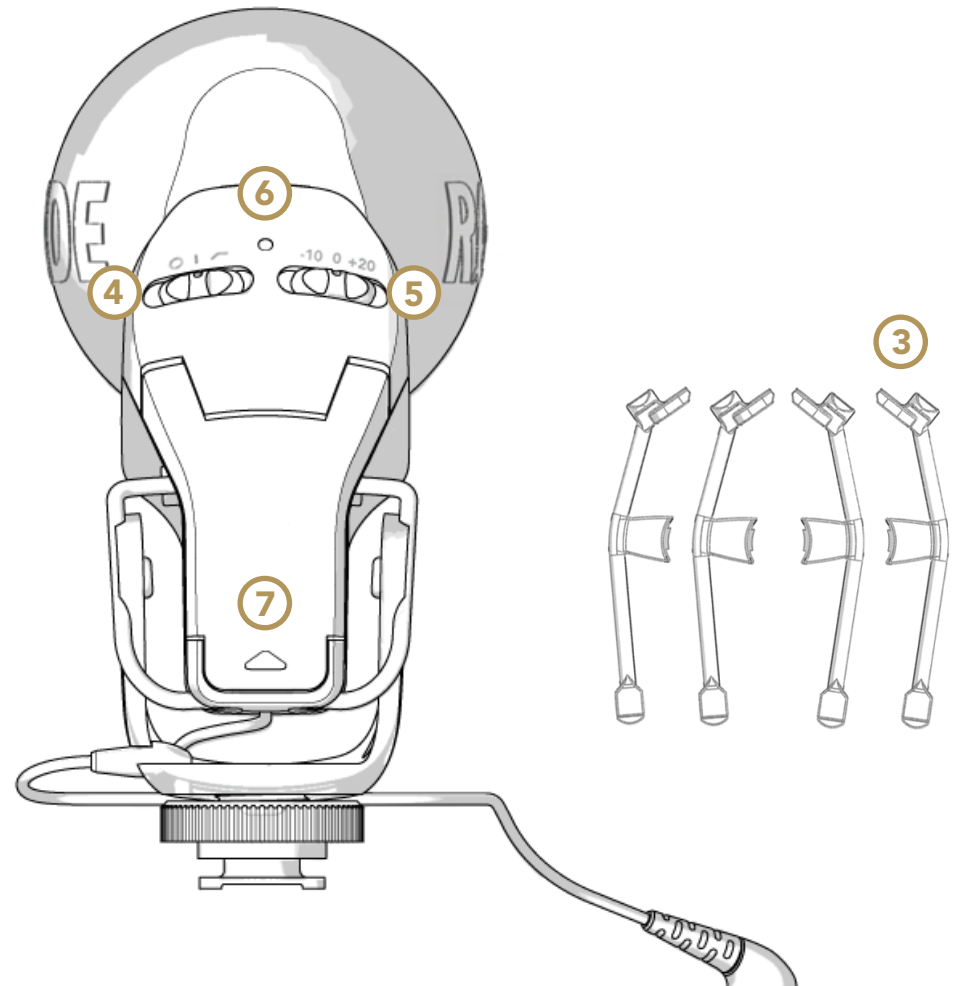

SETUP AND USE

INSTALLING THE BATTERY

Before you can record with your Stereo VideoMic Pro, you will need to install a standard 9V battery (ANS1:1604A or IEC:6LR61). RØDE recommends using a high quality lithium or alkaline battery to achieve the best possible battery life.

To install the battery, open the battery cover that is located on the back of the Stereo VideoMic Pro, just under the switch controls. To open, hold the microphone in one hand, and in the other hand hold the sides of the battery cover between your thumb and index finger. Pull the cover in an upwards motion until it clicks out of place.

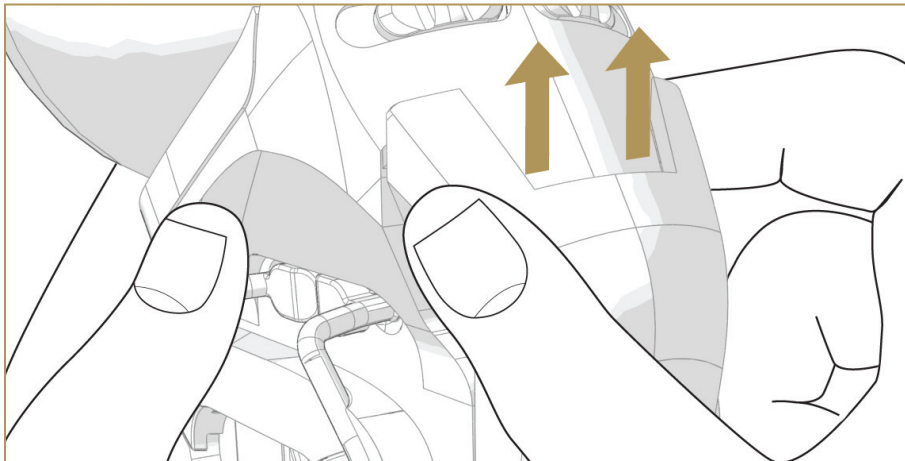

Hold the sides of the battery cover between thumb and index finger and pull upwards to remove

Insert the battery with the negative terminal (-) on top as shown in the next diagram. The correct battery orientation is also shown on the inside of the battery cover. If the battery orientation is incorrect the cover will not close fully.

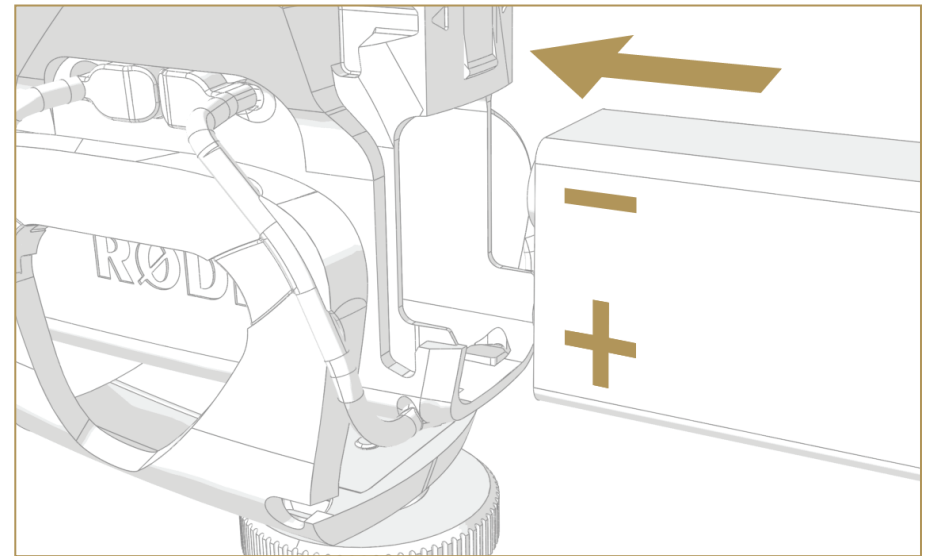

Insert the battery with the negative terminal on top

Replace the battery cover by sliding it into the clips at the bottom of the battery cavity using a downward motion. Press the cover down firmly to click it into place.

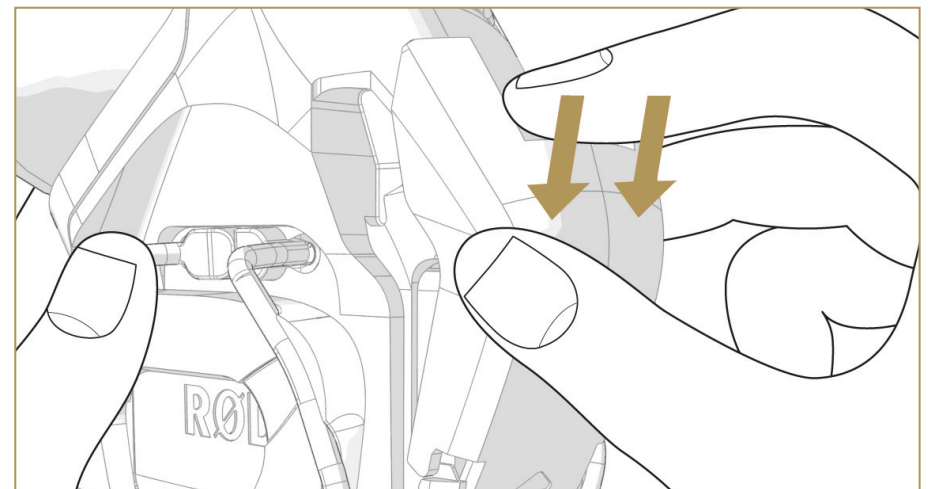

SETUP AND USE

The Stereo VideoMic Pro will run continuously for over 100 hours with a high quality alkaline or lithium battery. Battery performance may vary depending on ambient temperature and battery shelf life, so it is wise to always carry a spare battery. We suggest always installing a fresh battery when the application is critical, with no opportunity to re-shoot. Always remember to switch off the Stereo VideoMic Pro when not in use.

MOUNTING AND CONNECTING YOUR STEREO VIDEOMIC PRO

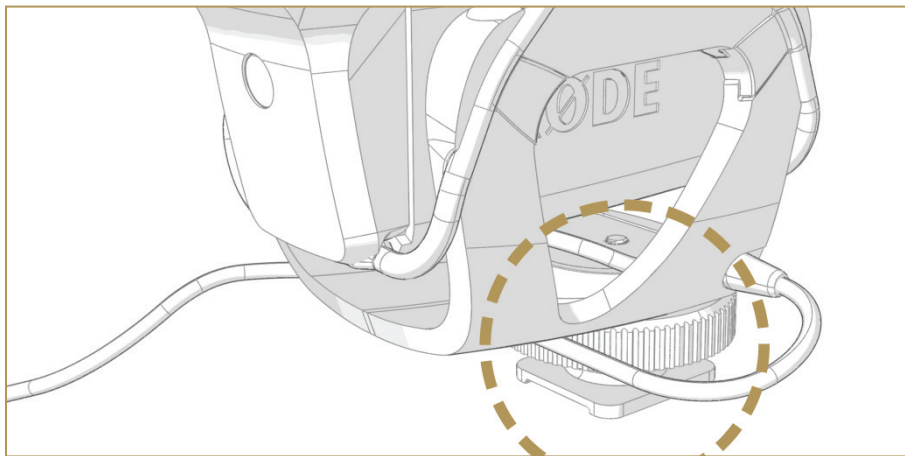

The standard shoe mount on the Stereo VideoMic Pro

The Stereo VideoMic Pro incorporates a standard camera shoe mount on the underside of the shock mount cradle.

Designed to reduce handling and mechanical noise being carried through from the camera to the microphone, the camera shoe mount also has a 3/8" thread at the bottom to allow mounting on tripods and boompoles.

Some older model and low cost cameras may produce a higher level of mechanical noise, which can be picked up by the Stereo VideoMic Pro. The integrated High Pass Filter should be switched on to reduce the resulting low frequency rumble.

(Refer to page 8 for more details on engaging the High Pass Filter.)

Before sliding the camera shoe into place, loosen the fastening ring by turning anti-clockwise until it is loose enough to fit easily into your camera's shoe mount. Once the shoe is in place, gently tighten by turning the fastening ring clockwise until the Stereo VideoMic Pro is seated firmly in place.

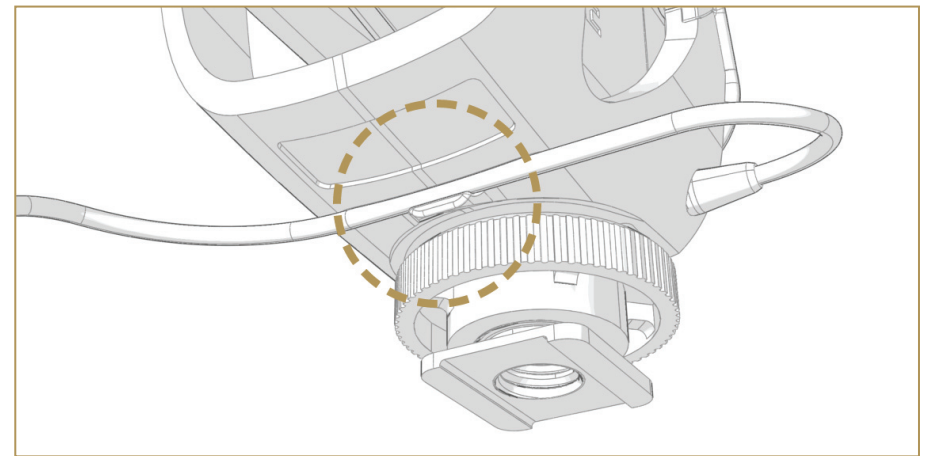

Press your cable into the cable management clip on the underside of the shock mount cradle

The Stereo VideoMic Pro has a small cable clip on the underside of the shock mount to secure the cable in place and prevent any unwanted movement noise. Simply press your cable into the clip / groove until the cable is secured in place.

SETUP AND USE

The Stereo VideoMic Pro delivers a mic level signal to the video camera via a stereo mini jack audio lead. The mini jack should be connected to the camera via the camera's "audio-in" socket – refer to your video camera user manual for the location of the socket on your camera model.

Now that you have the Stereo VideoMic Pro securely fastened to your camera and the audio output lead connected, you can switch the microphone on and start recording.

STEREO VIDEOMIC PRO CONTROLS

ON / OFF AND HIGH PASS FILTER SWITCH

The power / HPF switch is located on the back of the microphone body.

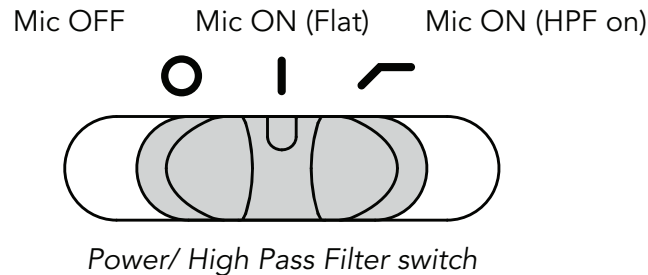

The High Pass Filter (HPF) is a low frequency cut-off setting, which you can use to reduce rumble and other low frequency noise picked up by the microphone while recording. It may affect the tone slightly but in some situations it is recommended.

For instance, it may be helpful to engage the High Pass Filter to cut out the sound of air conditioning, handling noise while adjusting

focus settings and distant traffic audible in the background. To engage the High Pass Filter, slide the power switch to the right hand position until it is pointing to where the HPF (↗) symbol is indicated.

LED POWER INDICATOR

The power indicator LED flashes RED briefly when the microphone is first turned on. This changes to GREEN indicating the battery has adequate charge.

When the battery runs low the LED will remain RED and you should replace the battery. The microphone will work for over ten hours once the RED indicator is lit, however with reduced performance. RØDE recommends changing the battery as soon as possible after the LED has turned red.

LEVEL CONTROL

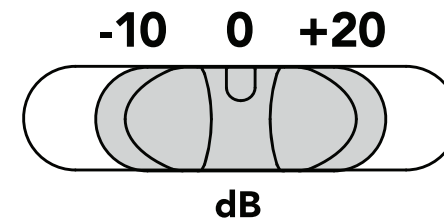

Three position level control switch

The Stereo VideoMic Pro features three settings to control the signal output level to your recording device. These are set via the right hand side selector switch on the back of the microphone.

SETUP AND USE

The left setting (-10) will reduce or attenuate the signal by 10dB, meaning that loud sound sources will be reduced and be less likely to overload or 'clip' the input of the camera.

The right setting (+20) will increase the signal level by 20dB. This is useful for recording quiet sound sources, or when your camera requires a higher input level for better signal to noise ratio (as in many digital SLR cameras).

Please note that when setting the input level you should always be mindful of your camera's internal audio level setting. If you have the +20dB level selected on the Stereo VideoMic Pro you may need to reduce the input level on your camera.

(For best results reduce the camera's input level as much as possible, selecting the +20dB input level on the Stereo VideoMic Pro and working downward until the appropriate input level is achieved. This will result in a much lower noise floor and an overall clearer recording when plugging the Stereo VideoMic Pro into the typically low quality mic preamps found on most DSLR cameras.)

The Stereo VideoMic Pro has been designed to work best with the camera's Auto Gain Control switched off. (see page 16 for more information on Auto Gain Control) As always it is recommended to test your audio first before recording anything of importance.

The Stereo VideoMic Pro has been RF/EMI shielded for very high rejection of radio frequency interference, but we suggest you keep all transmitters, cell phones, pagers etc. at least two metres away to reduce the possibility of interference affecting your recordings.



Loud sound levels can cause serious hearing damage.

Take care when setting the audio levels, especially while wearing headphones.

For additional recording tips and tricks, please visit the RØDE University – RØDE's free online microphone training website (www.rodeuniversity.com). Check out the Broadcast recording semester for tutorials most relevant to the Stereo VideoMic Pro.

For more entertaining videos, you may also wish to visit RØDE TV (www.rodetv.com) – featuring a wide range of demos, reviews, interviews and behind-the-scenes clips for anyone interested in music, audio and recording.

SETUP AND USE

REPLACING SHOCK MOUNT BANDS

The Stereo VideoMic Pro has been designed with an integrated suspension shock mount, reducing the amount of handling noise that is transmitted to the microphone while recording your audio.

This shock mount uses four elastomer suspension bands to hold the Stereo VideoMic Pro in its shock mount cradle. These bands have been created to be intentionally soft, again to minimise the transmission of mechanical and handling noise through this material.

If the Stereo VideoMic Pro is shaken vigorously or knocked during use, the microphone body may touch the sides of the shock mount cradle. This should be avoided as it may add unwanted noise.

During handling or transport, the bands attaching the Stereo VideoMic Pro to its shock mount cradle may become dislodged. They can easily be put back into place by hand. Also, if the bands should become damaged or worn over time, the old bands can be fully removed and replacement bands fitted. Please follow the instructions below to readjust or replace the bands as necessary.

Start by attaching your shock mount bands to the microphone body. The shock mount cradle will then slip easily up under the bands and support the microphone. You may then attach the microphone to the shock mount cradle by sliding the shock mount bands into place.

Consult the image to the right to determine which band to use on the relevant side of the microphone. There are four bands in total, two of each shape.

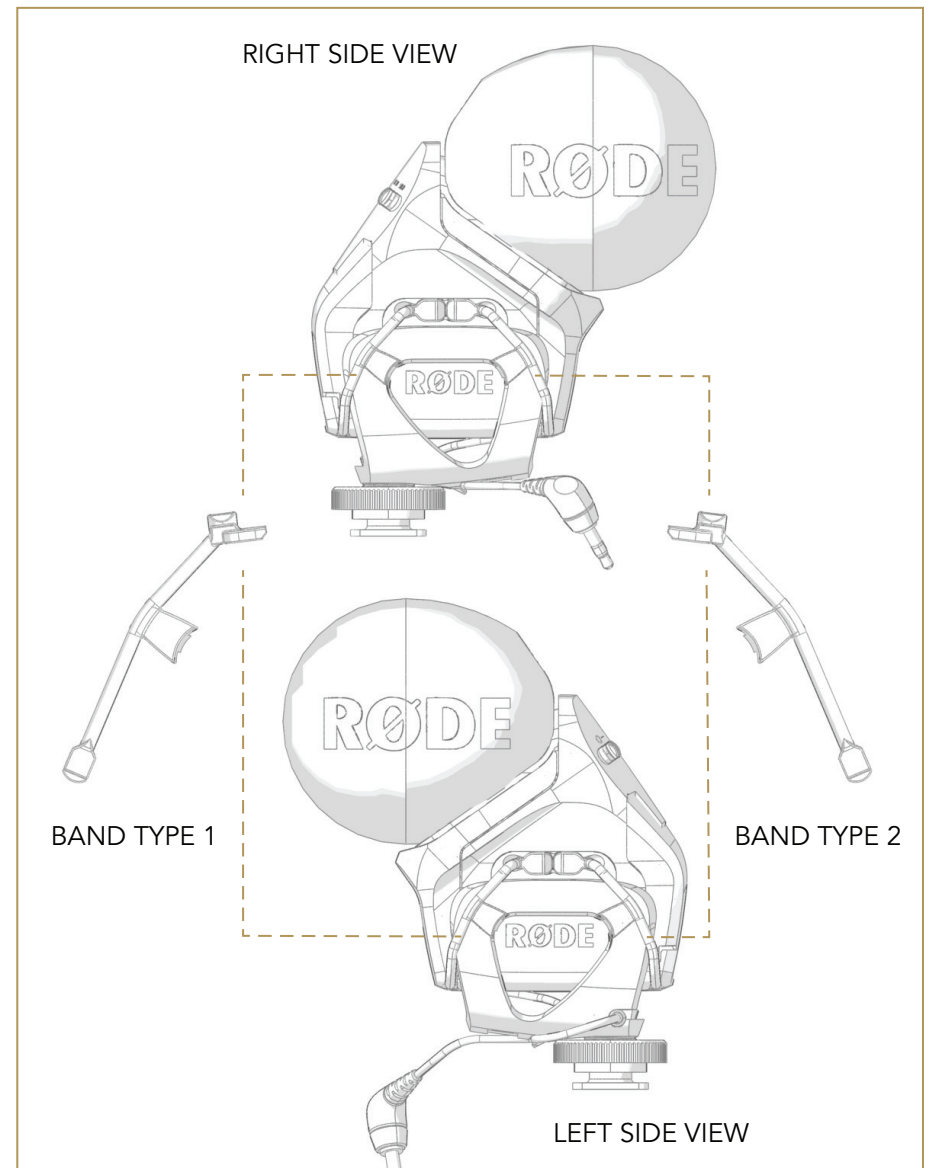

The Stereo VideoMic Pro shock mount bands come in two pairs. Check which shape corresponds to the part of the microphone you wish to attach to the shock mount.

SETUP AND USE

You will notice the bands have two square ends of different sizes. The larger end has a circular knob on one side. In the middle is a tapered square, also with a circular knob on one side.

To fit your band, match the shape of the band to the notches on the Stereo VideoMic Pro's body. The larger end of the band will fit into the notch near the top of the microphone body, and the smaller end of the band will fit into the notch on the underside of the microphone body. Ensure that the tapered square at the middle of the band has the knob side facing down, ready to press into the shock mount cradle.

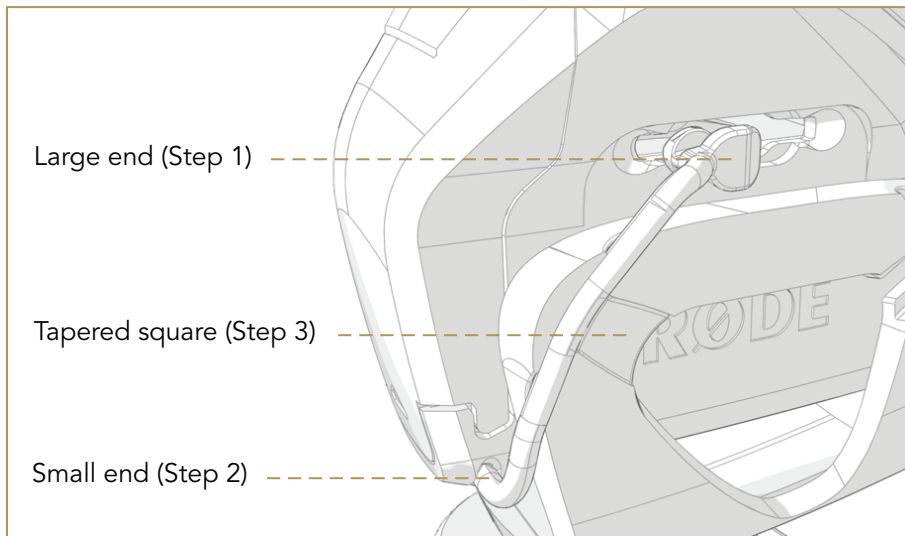

Match the shock mount band to the corresponding notches on the microphone and shock mount

Start with the larger end of the band and press into the notch near the top of the microphone body, ensuring the side featuring the circular knob is facing inward.

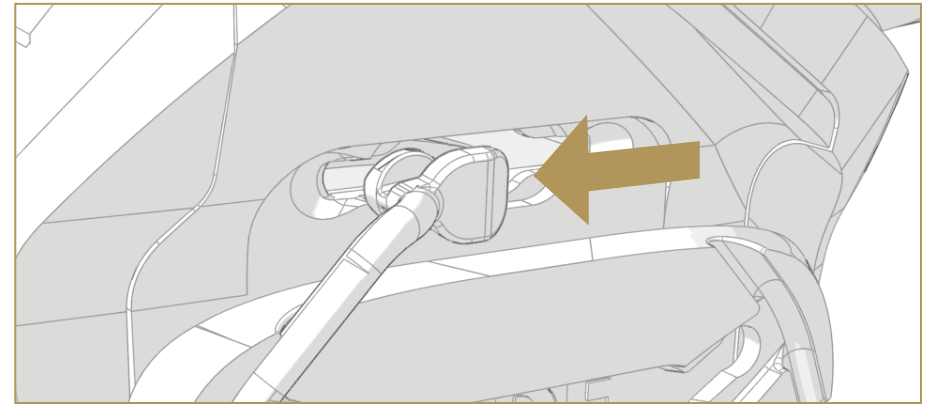

Pull until the knob on the band catches on the round end of the notch

Pull the band along the notch until you feel the knob catch into the round end of the notch.

Once the larger end is secured, press the smaller end of the band into the notch on the underside of the microphone body. The band should press in and hold easily. Repeat this process for all four shock mount bands.

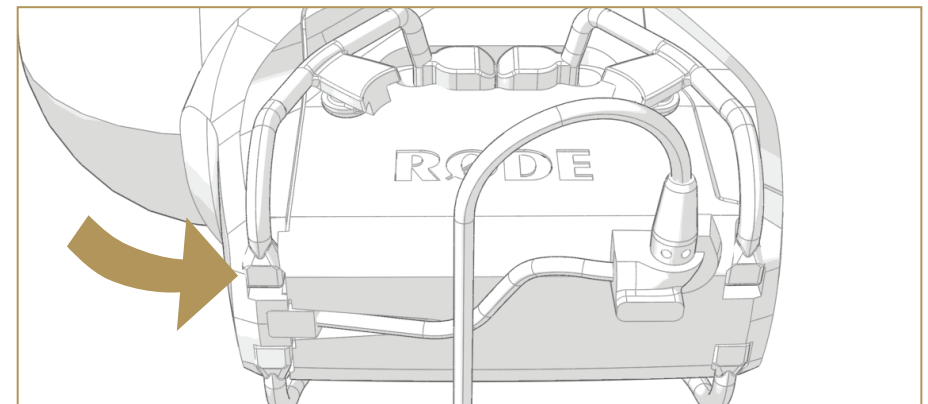

Press the smaller square end of the band into the notch on the underside of the microphone body

SETUP AND USE

Once all four bands are fitted on the microphone body, pull up the shock mount cradle underneath the bands. Note the correct alignment of the cradle will have the shoe mount on the cradle closer to the rear of the microphone.

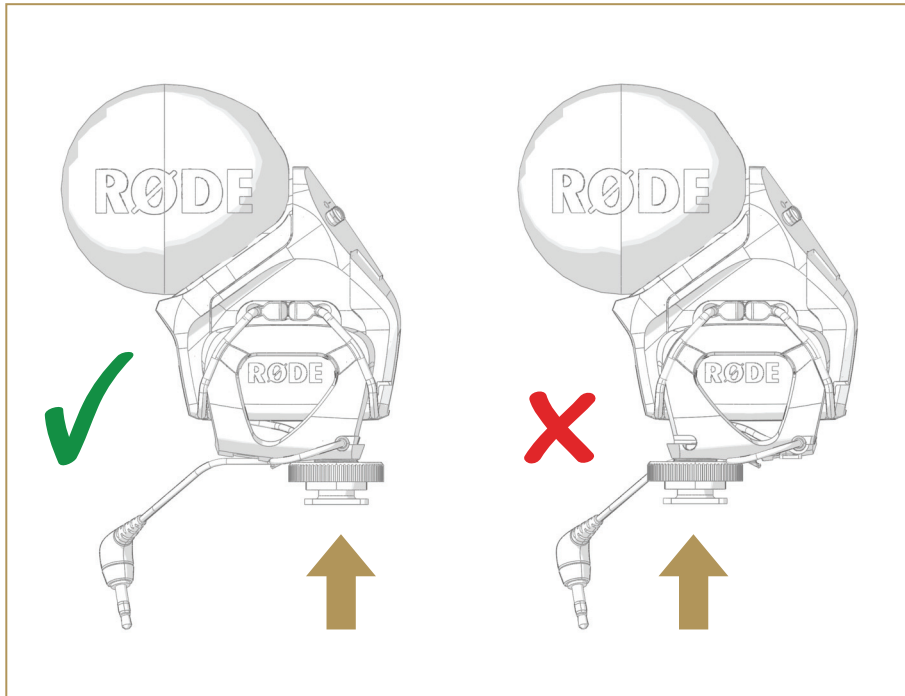

Check that the cradle is aligned so that the shoe mount is closer to the rear of the microphone

Next, slide the tapered square on the middle of the band into the notch on the shock mount. The circular knob on the inner side of the band will lock into the shock mount notch.

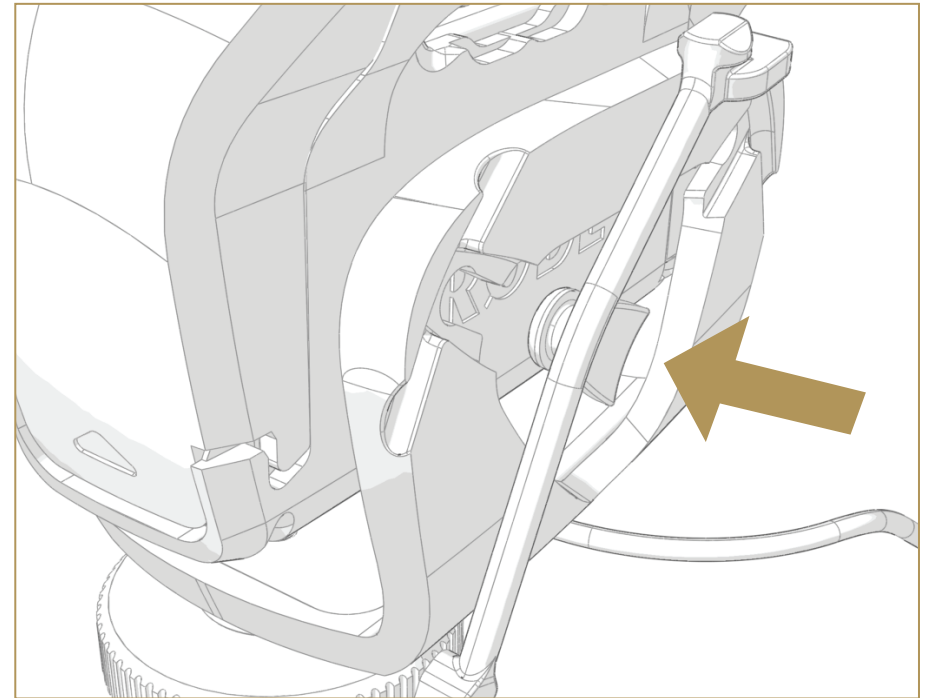

Slide the tapered square on the middle of the band into the notch on the shock mount

Repeat the process for all four bands, and the Stereo VideoMic Pro will be securely mounted to its shock mount cradle.

Note: The bands should press in and hold to the notches on the microphone body and shock mount cradle quite easily, as it is moulded to the shape of the notch required. If the band does not appear to fit well, you may have the wrong band shape for that area of the shock mount. Switch to the other band shape and try again.

OPTIONAL ACCESSORIES

DEAD KITTEN FURRY WINDSHIELD



For increased wind protection, an optional Dead Kitten furry windshield is available for the Stereo VideoMic Pro. The windshield is ideal for situations such as outdoor performances where wind noise may distort the audio quality of the microphone.

The Dead Kitten furry windshield fits over the foam windshield that comes pre-mounted on the Stereo VideoMic Pro. Do not remove the foam windshield before installing the Dead Kitten. To fit the Dead Kitten, use both hands to stretch the elastic opening and pull over the

Stereo VideoMic Pro's foam windshield. Ensure that the Dead Kitten is fitted right up to the edge of the microphone body and covers the full foam area, to prevent any leakage of wind noise. Finally, fluff up the Dead Kitten fur in all directions for optimum protection.

When removing the Dead Kitten windshield, keep hold of the foam underneath with one hand while using the other to gently pull away the Dead Kitten around the diameter of the elastic.

Please Note: After fitting the Dead Kitten for long periods of time, the foam windshield may appear squashed or disfigured. This is normal for high density acoustic foam and does not indicate damage – within a short period of time, the foam will regain its usual shape on its own. However if you wish you may gently remove the foam windshield and soak in cold water to reshape. Please ensure the foam is completely dry before refitting to your Stereo VideoMic Pro.

OPTIONAL ACCESSORIES

BOOMPOLES



The Stereo VideoMic Pro may be mounted on a Boompole, Mini Boompole or Micro Boompole via the 3/8" thread located at the bottom of the camera shoe mount. This allows you to move the microphone closer to your sound source independent of your camera.

To mount the microphone, match the thread on the Stereo VideoMic Pro to the screw at the tip of the boompole, and twist clockwise until securely fastened. The VC1 stereo extension lead will assist in connecting your microphone to your camera or sound recorder for remote use.

PG1 PISTOL GRIP



The Stereo VideoMic Pro can also be mounted on the PG1 pistol grip. This allows independent movement of the microphone from your video camera. The Stereo VideoMic Pro is mounted onto the PG1 via the shoe mount in the same way you would mount your microphone to your camera.

Before sliding the camera shoe into place, turn the fastening ring anti-clockwise to loosen and provide enough leeway. Slide the Stereo VideoMic Pro's camera shoe into the groove at the top of the PG1, rear first. Then twist the fastening ring clockwise to tighten until the microphone is fastened securely. The VC1 stereo extension lead will assist in connecting your microphone to your camera or sound recorder for remote use.

SAFETY / CARE INSTRUCTIONS

When not in use, always keep your Stereo VideoMic Pro in a cool, dry place, preferably in a camera bag or equivalent to protect from dust or damage. When not in use for long periods of time, remove the battery before storage. Do not expose the Stereo VideoMic Pro to rain or moisture.

It is recommended that the pre-fitted foam windshield be left on at all times possible to protect the microphone from dust and moisture.

In instances where the microphone has become exposed to the elements and the foam has become moist or dirty, it may be necessary to remove the foam gently and dry it separately to the microphone body to prevent moisture from damaging the microphone. Take care in this operation so as not to damage or tear the foam during removal. The foam windshield can be hand washed in cold water, then dried thoroughly in the sun before refitting.

Inside the Stereo VideoMic Pro box, you will find a sachet of moisture absorbent crystals. Please retain these crystals and store with the Stereo VideoMic Pro to keep the microphone in ideal condition.

Eventually this pack of crystals will need to be dried. This is indicated by the crystals turning pink in colour. They can easily be re-used by placing them in an oven at 100-150 degrees Celsius for approximately ten minutes. The crystals will operate effectively again once they have turned blue.

The Stereo VideoMic Pro has no internal user serviceable parts. Should you encounter a problem, please refer all servicing to qualified service personnel.



Loud sound levels can cause serious hearing damage.

Take care when setting the audio levels, especially while wearing headphones.

TROUBLESHOOTING / FREQUENTLY ASKED QUESTIONS

WHY DO I GET LOW-LEVEL BACKGROUND NOISE WHEN RECORDING ON MY CAMERA?

A low level background noise in your recordings is usually caused by Automatic Gain Control function (or AGC) on the camera.

This occurs when the camera cannot sense an audio input signal and automatically increases the gain (or level) of the audio input. When it is increased to the level that the noise floor in the camera microphone amplifier becomes audible, the low level sound will be present in your recording.

The Automatic Gain Control can be disabled on some camera models. This may sometimes require a firmware update to your camera. Please check with your camera manual or manufacturer for more information.

You can help combat this issue by engaging the +20dB level boost switch on your Stereo VideoMic Pro. This will increase the audio signal so that the camera is able to recognise a significant input level and reduce usage of Automatic Gain Control.

MY MICROPHONE DOESN'T FIT INTO THE SHOE MOUNT ON MY CAMERA

The RØDE cold shoe adaptor is a standard size adaptor, also known as a universal shoe mount. This standard shoe is suitable for the majority of camera attachments.

If your camera has a different, or custom adaptor, there are usually converters available, which can be used to connect your camera to accessories that use the universal shoe. Please contact your camera

manufacturer for information on the available converters for your camera model.

WHY CAN I HEAR A RATTLING NOISE FROM THE MICROPHONE WHEN IT IS MOVED / SHAKEN?

After a long period of use, the screw that fastens the camera shoe mount to the base of the Stereo VideoMic Pro may need to be tightened. A slight rattling noise when the Stereo VideoMic Pro is moved is an indicator the screw requires tightening. The screw is located inside the 3/8" thread mount cavity on the base of the shoe mount. Simply use a Phillips head screwdriver to tighten the screw.

If the screw on the base of the camera shoe mount is secure, make sure that the camera shoe fastening ring is screwed all the way down (Refer to page 7) and that battery cover is correctly installed. (Refer to page 6)

WHY DID RØDE USE A THIN CABLE ON MY STEREO VIDEOMIC PRO?

The Stereo VideoMic Pro has been designed with an ultra light, multi strand shielded dual core cable. This allows for far lower handling noise transference when compared to older style, thicker cables used in many video microphones currently on the market. The Stereo VideoMic Pro cable is incredibly strong and is rated to several thousand flex cycles, ensuring it will last a very long time.

Of course, the Stereo VideoMic Pro also comes with our industry leading 10 year warranty, ensuring complete peace of mind that your microphone is built to last.

TROUBLESHOOTING / FREQUENTLY ASKED QUESTIONS

WHERE CAN I ORDER REPLACEMENT SHOCK MOUNT BANDS FOR MY STEREO VIDEOMIC PRO?

The elastomer shock mount bands are available to order as a pack through your local RØDE distributor.

Please visit www.rodemic.com/wheretobuy to find your nearest distributor's contact details.

PRODUCT WARRANTY

RØDE Microphones prides itself on designing and manufacturing microphones of the highest quality and performance.

Our state-of-the-art engineering and manufacturing techniques, combined with decades of experience in professional audio and recording has resulted in microphones that will last a lifetime.

All RØDE Microphones are guaranteed for one year from the date of purchase. The Stereo VideoMic Pro warranty may be extended to a full ten year period. Extending your warranty is completely free of charge – simply register your purchase details on the RØDE website at [**www.rodemic.com/warranty***](http://www.rodemic.com/warranty*)

The warranty covers parts and labour that may be required to repair the microphone during the warranty period. The warranty excludes defects caused by normal wear and tear, modification, shipping damage, or failure to use the microphone as per the instruction guide.

The RØDE Microphones 10 Year Warranty gives you the peace of mind that your investment is protected for many years to come.

*subject to terms & conditions - see rodemic.com/warranty for full details

SUPPORT AND SERVICE

If you experience any problem, or have any questions regarding your microphone, first contact the dealer who sold it to you.

If the microphone requires a factory authorised service, return will be organised by that dealer.

We have an extensive distributor/dealer network, but if you have difficulty getting the advice or assistance you require, do not hesitate to contact us directly.

Technical Support

For information and technical support questions please visit www.rodemic.com/support