

NEXO

RS

Ray Sub Series

RS15 Subwoofer



User Manual

RaySub Series User Manual V1.01
Date: 10/12/2007

GOING ONE STEP FURTHER IN LOW FREQUENCY CONTROL: RAY SUB TECHNOLOGY

Radiation control of low frequencies is hard to achieve due to wavelength being larger than cabinet size. Consequently, most of current subwoofers available on the audio-professional market are omnidirectional.

Drawbacks in using omnidirectional subwoofers are known by experienced engineers:

- Low Frequency sound pressure level is typically higher on stage than over the audience; high-pass filters are mandatory in almost all microphones inputs to avoid feedback from the microphones to the subwoofers. Moreover, gain from microphone to speakers is highly limited due to that feedback (reinforcing a double-bass can be an enormous challenge);
- Indoor environments typically have much higher reverberation time in the Low Frequency range than in the mid and high Frequencies. This characteristic is emphasized by the omnidirectional pattern of conventional subwoofers (all sound engineers experienced kick drum lasting forever);
- Many outdoor shows occur nearby residential areas where noise constraints are very restrictive; in such cases, low frequencies levels over the audience have to be limited so that environment criterias are fulfilled (possibly leading to unacceptable wideband limitations).

Gradient subwoofers provide an elegant solution to the above issues, based on a technology that is a simple transposition to sound sources of what has been applied for decades in microphones: radiated field derives from pressure differences generated from two (or more) sources:

- Rear radiation is lowered by more than 12 dB, which benefits to stage as well as to neighbours;
- Direct to reverberant ratio is increased by nearly 6 dB in the low frequency range (which potentially gives back a kick drum its original "punch").

However, there are efficiency limitations: gain in lower bandwidth is reduced when sources become too close in relation to wavelength, and pattern control is limited in upper bandwidth when both sources interfere destructively in the radiation axis. Operating bandwidth where efficiency combines with pattern control is around 2 octaves.

Poor correlation between cabinet design and targeted specifications leads to two (and eventually more) drivers in directional mode producing less energy than one driver in omnidirectional mode, which is not acceptable for simple practical aspects such as weight and volume.

It is now 5 years that NEXO has released its first gradient subwoofer - the CD12 -, complemented since then with the CD18 and the GEO SUB. These have been quickly adopted worldwide as standards, and are considered today as state of the art subwoofers. This success is a consequence of proper cabinet design and optimized definition of phase relations through sophisticated DSP algorithms leading to high directional control and SPL output.

With RAY SUB patent pending technology, NEXO is again moving one step forward. RAY SUB technology is about optimizing positioning and phase relationship of radiating surfaces in vented enclosures, so that acoustic distance from rear to front sections always increases as frequency decreases; consequently, rear and front section always sum up efficiently - typically 5 dB gain from rear section in the forward direction - and cancel in the rearward direction.

Used as a single cabinet, RAY SUB Technology allows the same cabinet to be configured for any polar pattern, omnidirectional as a standard direct radiating subwoofer when speakers are facing the audience, or highly directional when cabinet is rotated speakers sideways or upwards.

Used in arrays, RAY SUB subwoofers can be set back to back, front to front, in vertical columns, and beam-steered upwards or downwards provided column length is sufficient.

NEXO RAY SUB technology brings a never achieved low frequency directional control to the sound reinforcement industry, raising one more time NEXO standards.

SAFETY ISSUES

IMPORTANT NOTICE CONCERNING HIGH SOUND PRESSURE LEVELS



Exposure to extremely high noise levels may cause a permanent hearing loss. Individuals vary considerably in susceptibility to noise-induced hearing loss, but nearly everyone will lose some hearing if exposed to sufficiently intense noise for a sufficient of time. The U.S. Government's Occupational and Health Administration (OSHA) has specified the following permissible noise level exposures: Sound Duration Per

Day In Hours	Sound Level dBA, Slow Response
8	90
6	92
4	65
3	97
2	100
1 ½	102
1	105
½	110
¼ or less	115

According to OSHA, any exposure in excess of the above permissible limits could result in some hearing loss. Ear plugs or protectors to the ear canals or over the ears must be worn when operating this amplification system in order to prevent a permanent hearing loss, if exposure is in excess of the limits as set forth above. To ensure against potentially dangerous exposure to high sound pressure levels, it is recommended that all persons exposed to equipment capable of producing high sound pressure levels such as this amplification system be protected by hearing protectors while this unit is in operation.

SYSTEM RIGGING SAFETY RULES



Before use of RS Subwoofers, please ensure that anyone involved in system deployment understands the rigging and stacking Safety rules as described in the "RS15 HARDWARE, SAFETY FIRST" section. Failure to do this exposes people to potential injury or death.

ELECTRICAL SAFETY

WARNING ! GEO S12 TDCONTROLLER, NX242 DIGITAL CONTROLLER, NXAMP4x1 AND NXAMP4x4 POWERED CONTROLLERS ARE CLASS 1 APPARATUS AND MUST BE EARTHED.



The green and yellow wire of the mains cord must always be connected to an installation safety earth or ground. The earth is essential for personal safety as well as the correct operation of the system, and is internally connected to all exposed metal surfaces.

TABLE OF CONTENTS

1	Introduction	8
2	RS15 General Instructions	10
2.1	“RS15 Left” and “RS15 Right”	10
2.1.1	RS15 LEFT	10
2.1.2	RS15 RIGHT	10
2.2	Mounting Optional Accessories.....	11
2.2.1	RS15 Handles	11
2.2.2	RS15 Flying Plates with handles (touring applications)	11
2.2.3	RS15 Wheels.....	12
2.2.4	RS15 Dolly.....	13
2.3	Speaker connection	14
2.3.1	Configuring Connector and Owner plates	14
2.3.2	RS15 connectors	14
2.3.3	Cabling.....	15
2.3.4	Example.....	15
3	Amplifier selection for use with RS15	16
3.1	RS15 recommended amplification	16
3.1.1	Current rating.....	16
3.1.2	Amplifier settings	16
3.2	RS15 and NXAMP TDControllers	18
3.2.1	NXAMP connectors	18
3.2.2	RS15 and NXAMP recommended configurations	18
4	RS15 Setups on NEXO TD Controllers	19
4.1	Analogue GEOS12 TDController	19
4.2	Digital NX242-ES4 and NXAMP TDControllers	19
5	Connection diagrams	20
5.1	RS15 with GEOS12 TDController (Mono Omni Mode).....	20
5.2	RS15 with NX242-ES4 TD Controller (Stereo Omni Mode)	21
5.3	RS15 with NX242-ES4 TD Controller (Stereo Directional Mode).....	22
5.4	RS15 with NXAMP (Stereo Omni Mode)	23
5.5	RS15 with NXAMP (Stereo Directional Mode).....	24

6	RS15 Rigging Instructions	25
6.1	SAFETY FIRST	25
6.1.1	Flown Systems Safety	25
6.1.2	Ground Stacking Safety	26
6.1.3	Contacts	27
6.2	Flying RS15 arrays	28
6.2.1	Hoist Rating	28
6.2.2	Connecting first RS15 to bumper	28
6.2.3	Adjusting rigging point for horizontality	29
6.2.4	Flying the second RS15	30
6.2.5	Flying subsequent RS15's	31
6.3	Testing and Maintenance of the RS15 flying system	32
7	General guidelines for subwoofer design	33
7.1	Low Frequency Issues	33
7.2	Gradient Subwoofers benefits	34
7.3	Monophonic Design	34
7.4	Stereo Design	35
8	RAY SUBs implementation	36
8.1	Omnidirectional Mode	36
8.1.1	Single RS15	36
8.1.2	RS15 arrays	36
8.2	Directional Mode	36
8.2.1	Single RS15	36
8.2.2	RS15s pair	37
8.2.3	RS15s arrays	39
8.3	Steered RS15s arrays	39
8.3.1	Steering technique	39
8.3.2	Delay values implementation	40
8.3.3	Coverage result	41
8.4	Aligning RS15s with main system	41
8.4.1	NEXO systems acoustic reference point	41
8.4.2	Precautions	42
8.4.3	Alignment with distance measurement	42
8.4.4	Alignment with phase measurement	43
8.5	Recommended installation tools and equipment	43

9	RS15 System Check List	44
9.1	Are the NX Digital TDcontrollers properly configured?	44
9.1.1	NX settings	44
9.2	Are the amplifiers properly configured?	44
9.3	Are the amps and the NX properly connected?	44
9.4	Are the speakers properly connected?	44
9.5	Final Pre-Sound Check Check.....	45
10	RS15 Technical Specifications	46
10.1	System specifications	46
10.2	Dimensions.....	47
10.3	Diagrams	47
10.3.1	Frequency Response and Impedance	47
10.3.2	Polar plots.....	48
10.4	RS15 Accessories	50
10.4.1	RS15-BUMPER	50
10.4.2	RS15-FPLATES	50
10.4.3	RS-15 HANDLES	50
10.4.4	RS15-WHEELS	51
10.4.5	RS15-DOLLY.....	52
10.4.6	RS15 Push-Pins (BLGEOS).....	52
10.5	GEO S12 Analogue TDController	53
10.5.1	Specifications	53
10.5.2	Front and Rear Panel view	53
10.6	NX242 Digital TDController with NX-Tension Card	54
10.6.1	Specifications	54
10.6.2	Front and Rear Panel view	54
10.7	NXAMP4x1 & NXAMP4x4 Powered Digital TDControllers	55
10.7.1	Specifications	55
10.7.2	Front and Rear Panel view	56
11	RS15 Parts & Accessories List	57
11.1	Modules & Control Electronics List	57
11.2	Accessories List	57
12	USER NOTES	58

1 INTRODUCTION

Thank you for selecting a NEXO RS15 Subwoofer System. This manual is intended to provide you with necessary and useful information about your RS System, which includes the following products:

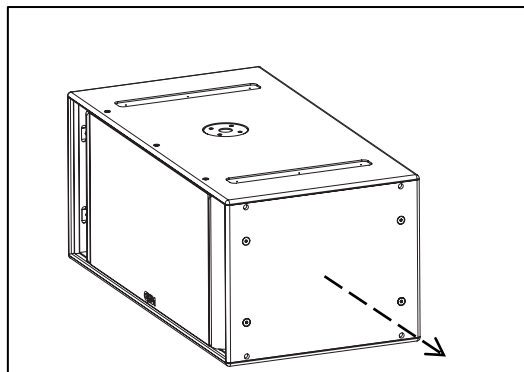
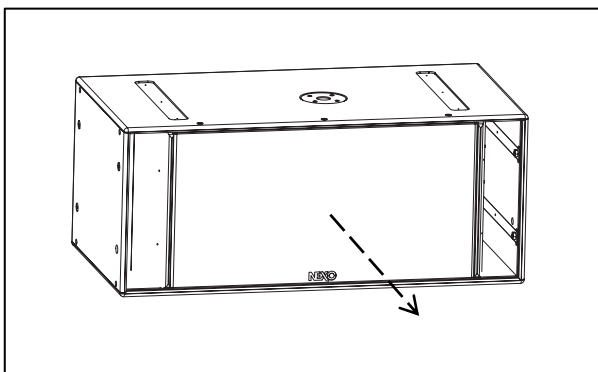

- RS15 is a Directivity Configurable Subwoofer, which comprises two 15" (38cm) long excursion Neodymium direct radiating drivers mounted in a dual volume vented enclosure with aerodynamic profiled vents; its coverage ranges from omnidirectional to highly directional and its frequency response extends from VLF to LF ranges (35Hz-200Hz). Painted and Carpeted versions are available.
- a full range of accessories that provides safe, flexible and simple means of transporting and installing RS15 subwoofers in fixed installation as well as in touring applications. These include flying hardware and dolly.

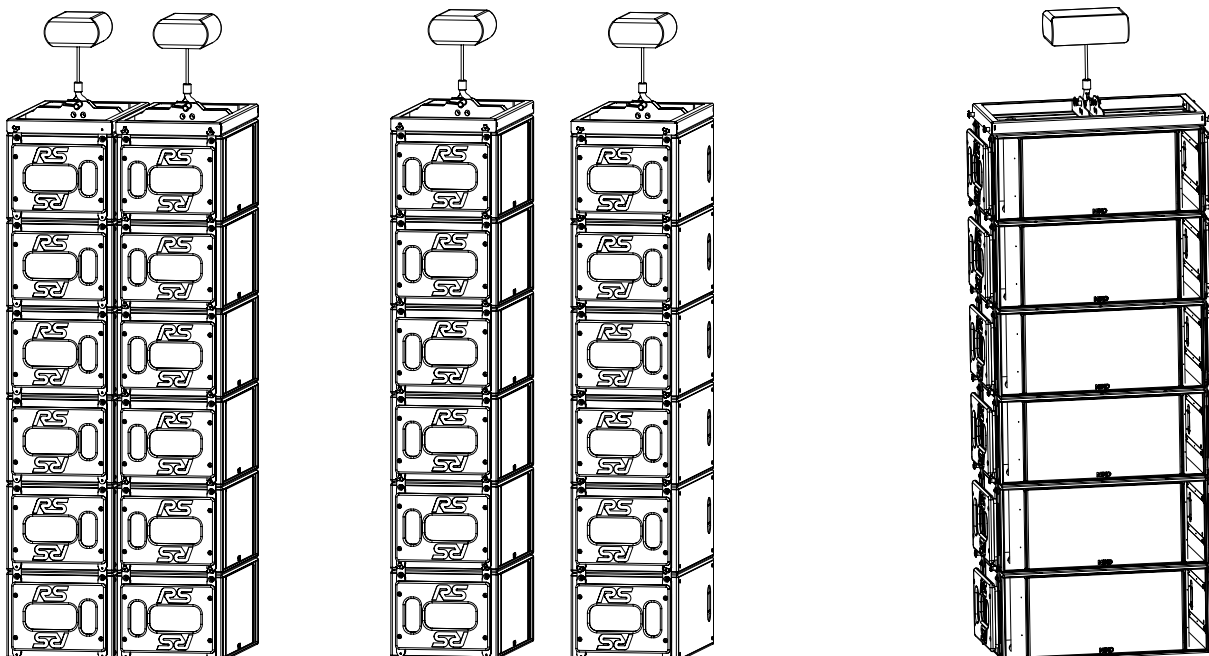

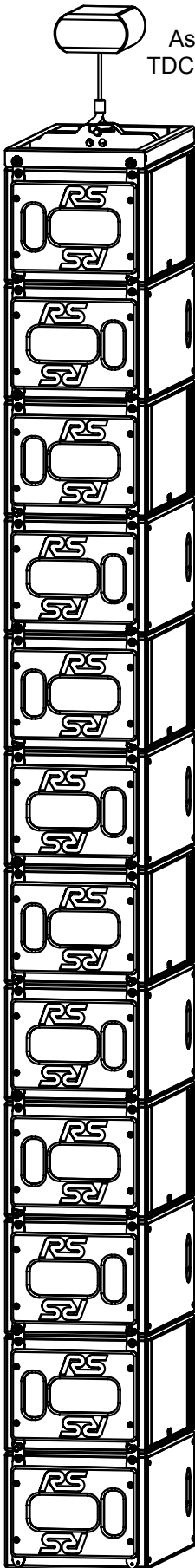

As for all NEXO systems, the RS15 is controlled, powered and monitored by dedicated NEXO TDControllers:

- GEO S12 TDController is based on PS analogue TDController design, and provides full control for RS15 in omnidirectional mode associated to Geo S12. It has 2 analogue inputs (Left and Right) and 3 analogue outputs (RS15 Mono Omni, GeoS12 Left and GeoS12 Right);
- NX242-ES4 Digital TDController provides comprehensive control of RS15 loudspeakers in multiple configurations. It allows Ethersound™ digital audio networking, as well as remote control for all units in the network. It has 2 analogue / 4 digital inputs and 4 analogue / 4 digital outputs;

IMPORTANT : NX242 must be equipped with NX-Tension Card (ES4 or CAI) to access RS15 setups

- NXAMP4x1 and NXAMP 4x4 are Powered Digital Controllers, providing full control and amplification for RS15 in multiple configurations. Both devices feature 4 analogue inputs and 4 speaker outputs. When equipped with optional card, 4 digital inputs in Ethersound™ digital audio network format as well as remote control for all units in the network become available.

For a complete description of these controllers, please refer to User Manuals. The NX242 and NXAMP DSP algorithms and parameters are fixed in software and updated regularly: Please consult the NEXO web site (www.nexo.fr) for the latest software releases.

Please devote your time and attention to reading this manual. A comprehensive understanding of RS15 specific features will help you to operate your system at its full potential.

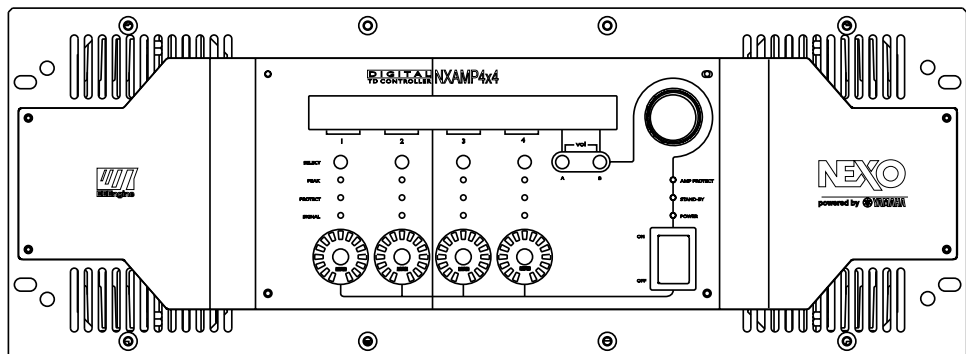
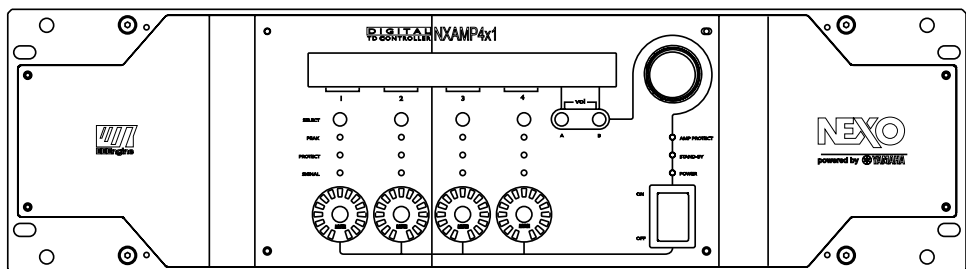
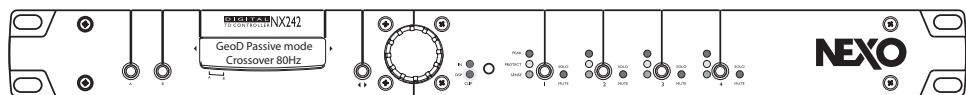
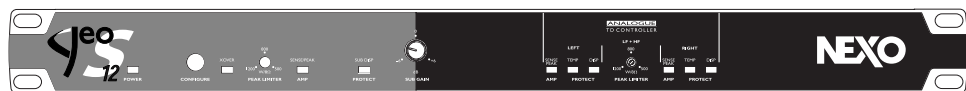

2 RS15 GENERAL INSTRUCTIONS

2.1 “RS15 Left” and “RS15 Right”

NEXO RS15 Subwoofer is delivered with a pair of skids to be mounted on the cabinet.

NEXO recommends to create pairs of “RS15 LEFT” and “RS15 RIGHT” for optimized flexibility.

Benefits of such recommendation are related to directional use in array configurations, where RS15s are to be positioned back to back, face to face or in vertical columns alternating speaker side.

However, users might prefer to have all RS15s configured identically, in which case they should all be “RS15 RIGHT” so that skids are opposite to pole stand hole.

Tools: TORX #25 and ALLEN key 6mm

2.1.1 RS15 LEFT

Mounting skids on the pole stand hole side defines a “RS15 LEFT”.

In such a case, front grid must be removed, flipped over and reinstalled so that NEXO logo appears on the same side than the skids.

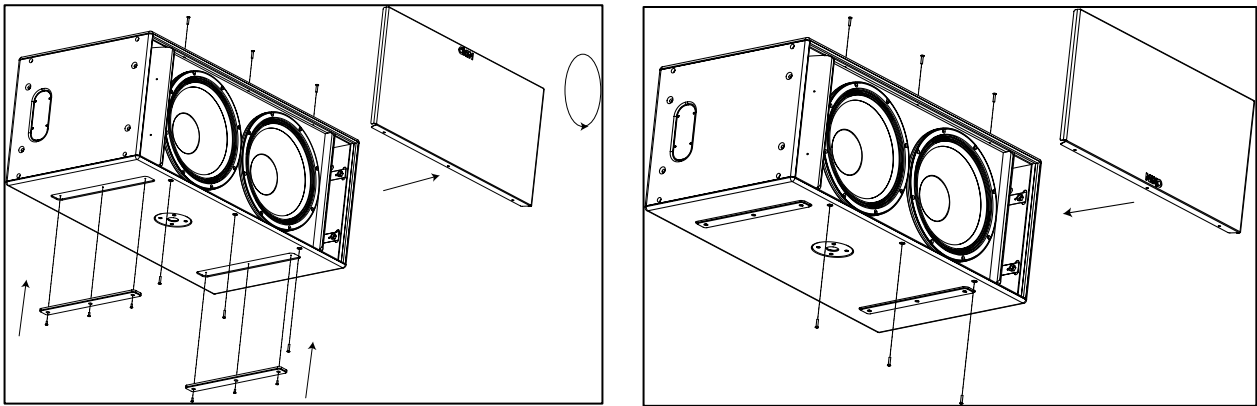

CONFIGURING RS15 AS LEFT

2.1.2 RS15 RIGHT

Mounting skids opposite to the pole stand hole side defines a “RS15 RIGHT”.

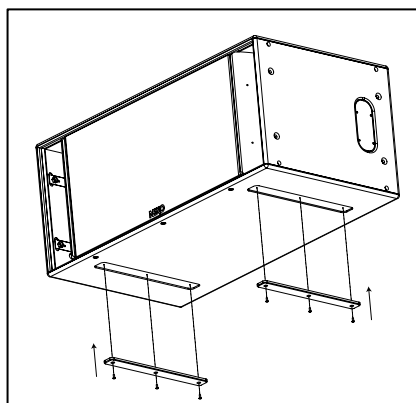

CONFIGURING RS15 AS RIGHT

2.2 Mounting Optional Accessories

IMPORTANT

IN ORDER TO PREVENT SCREWS FROM GETTING LOOSE, USE BLOCKING LIQUID LOCTITE™ 243 OR EQUIVALENT FOR ALL SCREWS USED WITH RS15 ACCESSORIES.

2.2.1 RS15 Handles

- Tools: TORX #50
- Remove the four screws on each side of RS15
- Fill each screw hole with Loctite 243 or equivalent;
- Position spacers and handles according to below drawing (vertical opening must be aligned with connector panel or owner's plate)
- Insert the four washers and screws provided with the RS15-HANDLES kit and tight them.

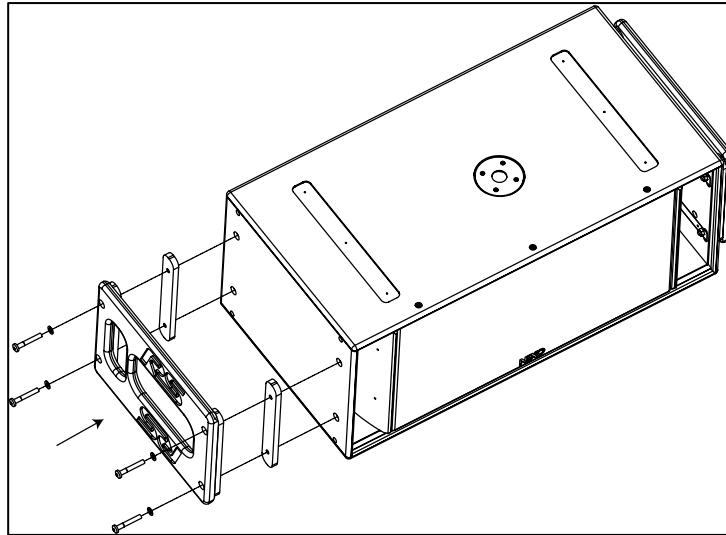

INSTALLING RS15 HANDLES

IMPORTANT

RS15 handles must not be used to fly RS15's (through illegal use of straps for example)

2.2.2 RS15 Flying Plates with handles (touring applications)

IMPORTANT

- Tools: TORX #50
- Remove the four screws on each side of RS15;
- Fill each screw hole with Loctite 243 or equivalent;
- Position flying bars so that articulated link bars are opposite to skids, ie at the top of the cabinet;
- Position handles according to below drawing (vertical opening must be aligned with connector panel or owner's plate);
- Insert the four washers and screws provided with the RS15-FLPLATES kit and tight them (torque value must be 10 Nm minimum).

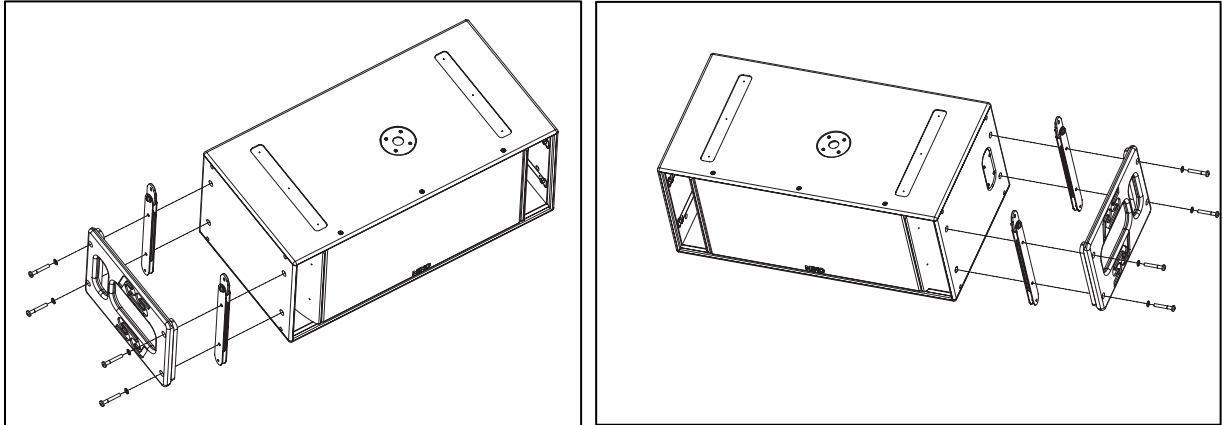

INSTALLING RS15 FLYING PLATES AND HANDLES

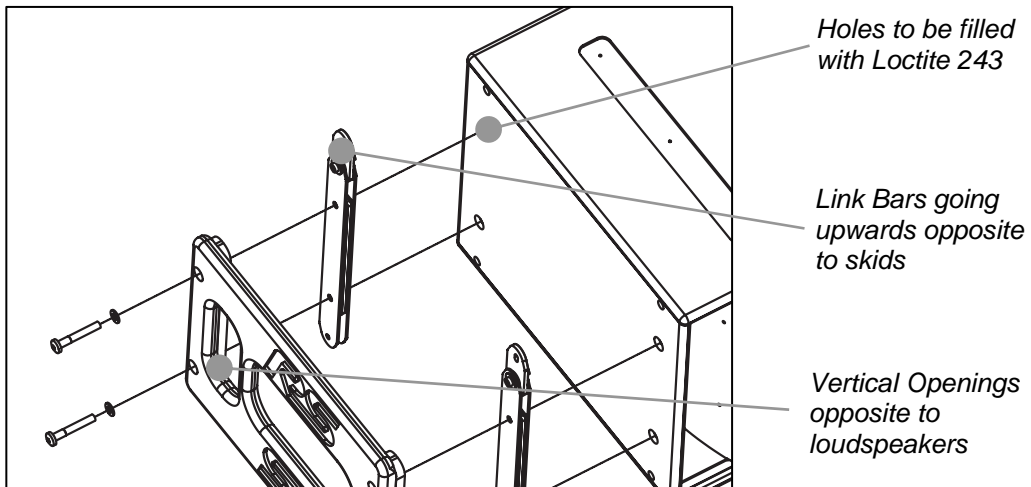

2.2.3 RS15 Wheels

- Tools: HEXE #13
- Remove the four screws on RS15 back panel;
- Fill each screw hole with Loctite 243 or equivalent;
- Position wheels according to below drawing;
- Insert the 8 washers and 4 screws provided with the RS15-WHEEL kit (see detail in below drawing) and tight them.

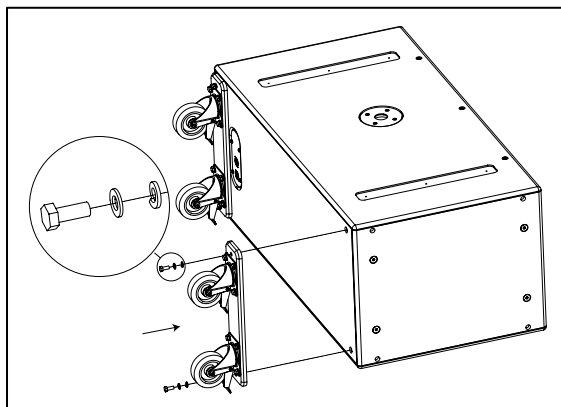

2.2.4 RS15 Dolly

IMPORTANT

- 1- TRANSPORTING RS15 ON DOLLY REQUIRES THAT FLYING PLATES ARE INSTALLED ON ALL CABINETS SO THAT RS15'S CAN BE SECURED TOGETHER:
- 2- RS15 DOLLY IS DESIGNED FOR UP TO 3 RS15'S AND BUMPER;
NEVER EXCEED THESE QUANTITIES.

- The first RS15 must be locked to the RS15 dolly using four push-pins according to below drawing;
- Subsequent RS15s are stacked on top using four push-pins per additional cabinet to secure the assembly;
- Bumper is to be attached to the top cabinet.

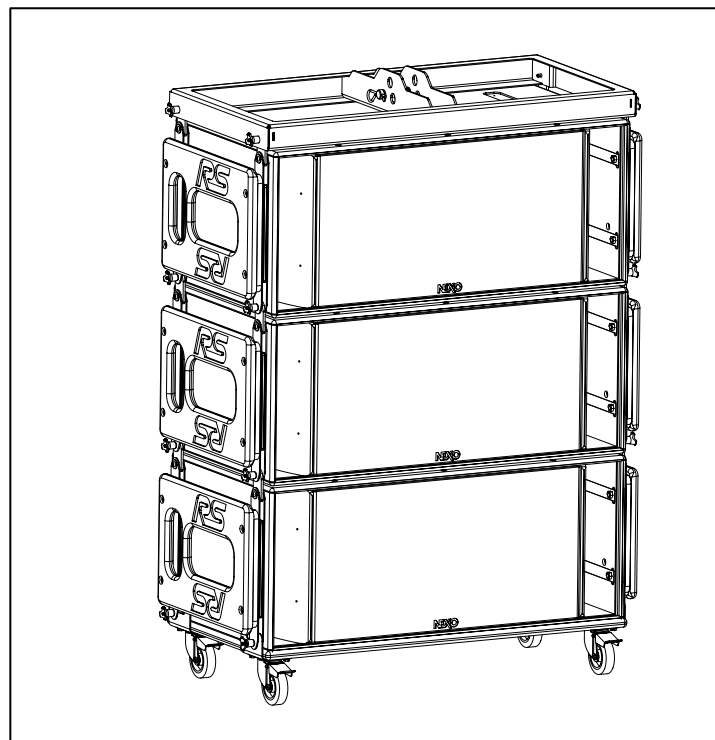
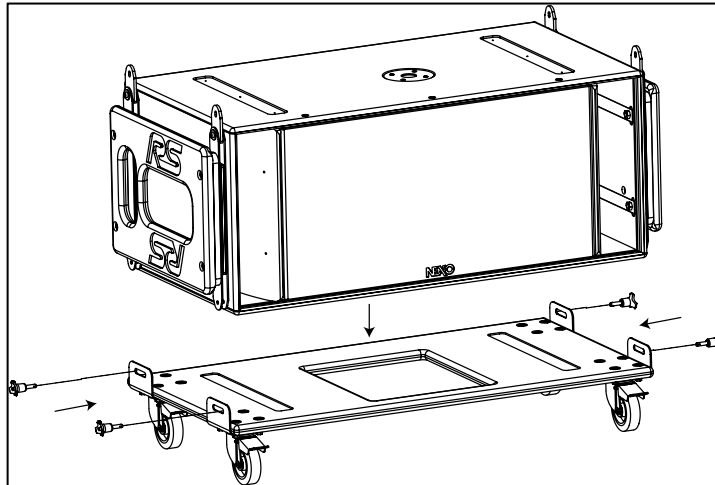

2.3 Speaker connection

2.3.1 Configuring Connector and Owner plates

Owner and Connector plates can be exchanged depending on chosen directional configuration

Please note that the connector plate can pass through the holes, no unsoldering is therefore required.

- Directional Mode : it is recommended to install the connector panel on the side which supports the rigging plates;
- Omni Mode: it is recommended to install the connector panel on the side opposite to the drivers (factory default configuration)

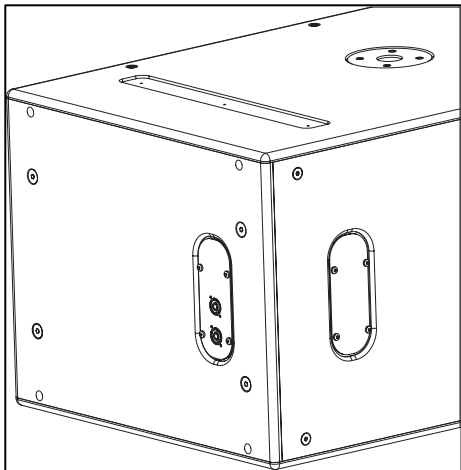

CONNECTOR PLATE IN DIRECTIONAL MODE

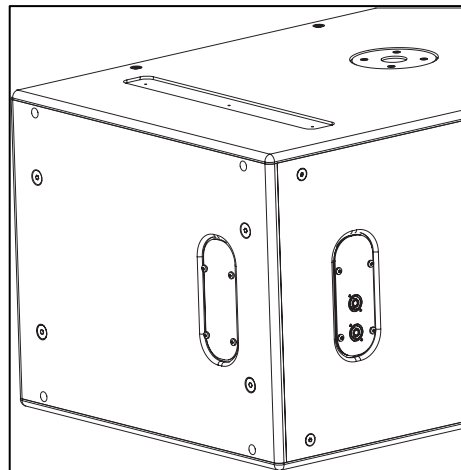

CONNECTOR PLATE IN OMNI MODE

2.3.2 RS15 connectors

RS15 is connected through Speakon NL4FC plugs (not supplied). A wiring diagram is printed on the connection panel located on the back of each cabinet.

The 4 pins of the 2 Speakon sockets are connected in parallel within the enclosure.

Either connector can be used to connect an amplifier or to link to an additional RS15 cabinet.

Connectors are wired as follows:

Speakon NL4F Connectors		Omni Mode	Directional Mode	Comment
1(-)	⇒	15'' driver Right (-)	15'' driver Rear (-)	Driver Next to Connector Panel
1(+)	⇒	15'' driver Right (+)	15'' driver Rear (+)	
2(-)	⇒	15'' driver Left (-)	15'' driver Front (-)	Driver Opposite to Connector Panel
2(+)	⇒	15'' driver Left (+)	15'' driver Front (+)	

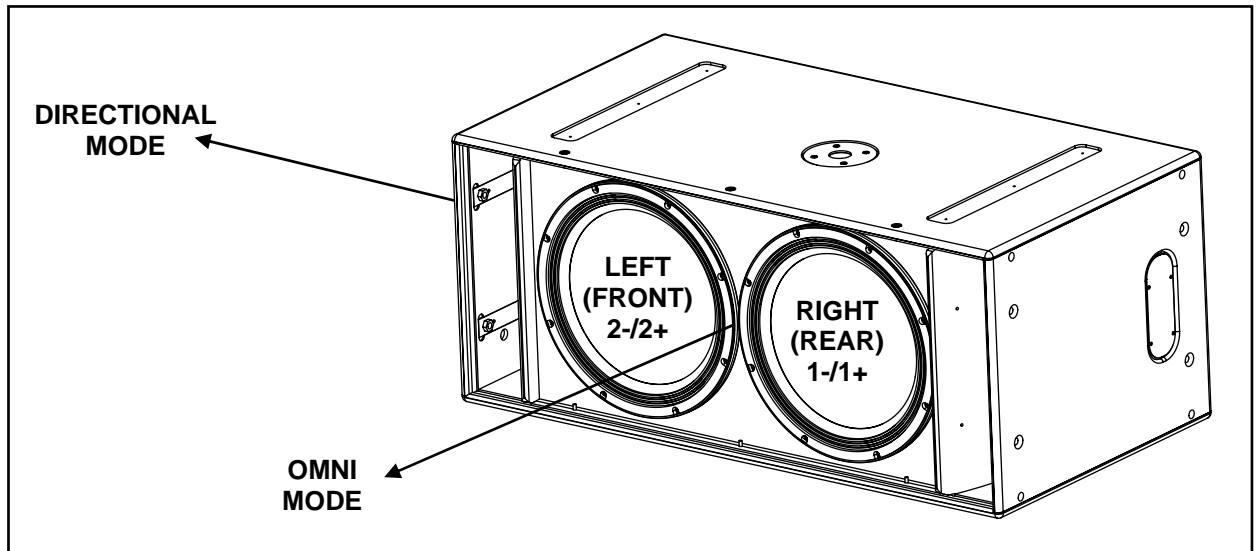

2.3.3 Cabling

NEXO recommends the exclusive use of multi-conductor cables to connect the system: the cable kit is compatible with all the cabinets, and there is no possible confusion between Front and Rear drivers.

Cable choice consists mainly of selecting cables of the correct sectional dimension (size) in relation to the load resistance and the cable length. Too small a cable section will increase both its serial resistance and its capacitance; this reduces the electrical power delivered to the loudspeaker and can also induce response (damping factor) variations.

For a serial resistance less or equal to 4% of the load impedance (damping factor = 25), the maximum cable length is given by:

$$L_{\max} = Z \times S \quad S \text{ in mm}^2, Z \text{ in Ohm, } L_{\max} \text{ in meters}$$

The table below indicates these values, for 3 common sizes.

Load Impedance (Ω)	2	4	8
Cable section	Maximum Length (meters)		
1,5 mm ² (AWG #14)	3	6	12
2,5 mm ² (AWG #12)	5	10	20
4 mm ² (AWG #10)	8	16	32

2.3.4 Example

- Each RS15 driver has a 8 Ohms nominal impedance; in omni mode, both loudspeakers can be driven in parallel on one amplifier channel, presenting therefore a $8/2 = 4$ Ohms load impedance. The maximum acceptable 2×2.5 mm² (AWG #12) cable length L_{\max} for RS15 with its 2 drivers in parallel is 10 meters.
- When driven in directional mode, RS15 requires 2 amplifier channels, presenting therefore two independent 8 Ohm load impedances. The maximum acceptable 4×1.5 mm² (AWG #14) cable length L_{\max} for RS15 with its 2 drivers driven independently is 12 meters.

IMPORTANT

Long speaker cables induce capacitive effects - up to hundreds of pF depending on the quality of the cable - with a high-pass effect on high frequencies. If long speaker cables must be used, ensure that they do not remain coiled while in use.

3 AMPLIFIER SELECTION FOR USE WITH RS15

NEXO recommends high power amplifiers in all cases. Budget constraints are the only reason to select lower power amplifiers. A lower power amplifier will not reduce the chances of driver damage due to over-exursion, and may actually increase the risk of thermal damage due to sustained clipping. If an incident occurs on an installation without protection, the fact that amplifiers only generating half their rated output power (-3dB) are used will not change anything in respect of possible damage. This is due to the fact that the RMS power handling of the weakest component in the system is always 6 to 10 dB lower than the amplifier rating.

3.1 RS15 recommended amplification

RS15 is rated for very high power handling and has a 2x8 Ohms nominal impedance.

These impedance value allow connection of up to 4 cabinets in parallel for each amplifier channel.

Nexo recommends amplifiers in agreement with table below:

Recommended Amplifier#	OMNI MODE	DIRECTIONAL MODE
1 x RS15	2 x 700 Watts to 1200 Watts / 8 Ohms or 1 x 1400 Watts to 2400 Watts / 4 Ohms (*)	2 x 700 to 1200 Watts / 8 Ohms
2 x RS15	2 x 1400 Watts to 2400 Watts / 4 Ohms or 1 x 2800 Watts to 4800 Watts / 2 Ohms (*)	2 x 1400 Watts to 2400 Watts / 4 Ohms
4 x RS15	2 x 2800 Watts to 48000 Watts / 2 Ohms	2 x 2800 Watts to 4800 Watts / 2 Ohms

(*) driving both drivers in parallel requires dedicated speaker cable

3.1.1 Current rating

It is very important that the amplifier behaves correctly under low load conditions. A speaker system is reactive by nature: on transient signals like music it will require four to ten times more instantaneous current than its nominal impedance would indicate. Amplifiers are generally specified by continuous RMS power into resistive loads; however the only useful information about current capacity is the specification into a 2 Ohm load. It is possible to perform an amplifier listening test by loading the amps with twice the number of cabinets considered for the application (2 speakers per channel instead of one, 4 instead of 2) and running the amps up to the onset of clipping. If the signal does not noticeably deteriorate, the amplifier is well adapted (overheating after approximately ten minutes is normal but thermal protection must not operate too quickly after starting this test).

3.1.2 Amplifier settings

Gain value

Gain is the key to correct alignment of the system. It is especially important to know the gain of all amplifiers used in your set-up. The tolerance should be about ± 0.5 dB. In practice this can be difficult to achieve because:

- Some amplifier brands have an identical input sensitivity for models of different power rating (this infers a different voltage gain for each model). For example, a range of amplifiers with different power outputs, all having a published input sensitivity of 775mV/0dBm or 1.55V/+6dBm, will have a wide range of actual gains – the higher the power, the greater the gain.
- Various other brands may offer constant gain but only within a given product range, for example they may fit fixed input sensitivity only on their semi-professional amps.
- Even if a manufacturer applies the constant gain rule to all models, the value selected will not necessarily be the same as that chosen by other manufacturers.
- Some products can exhibit manufacturing tolerances for the same model of ± 1 dB or more. Some amplifiers may have been modified, possibly without any label indicating the new values. Others may have gain switches fitted internally where it is impossible for the user to verify the actual setting without opening the amplifier casing.

- In cases where you don't know the gain of your amplifier (or want to check it) please follow this procedure:
 - 1) Unplug any loudspeakers from the amplifier outputs
 - 2) With a signal generator, feed a sine wave at 1000Hz at a known voltage (say 0.5V) to the input of the amplifier under test
 - 3) Measure the voltage at the output of the amplifier
 - 4) Calculate the gain using the formula $\text{Gain} = 20 * \text{LOG}_{10}(\text{Vout}/\text{Vin})$.

Some examples:

Vin / Gain	20dB	26dB	32dB	37dB (1.4V sensitivity / 1350Wrms)
0.1 V	1 V	2 V	4 V	7.1 V
0.5 V	5 V	10 V	20 V	35.4 V
1 V	10 V	20 V	40 V	70.8 V

Remember that constant sensitivity settings will give a different gain value when the amplifier power is different.

NEXO recommends low gain amplifiers: +26dB is recommended, as it is at the same time adequately low and quite common amongst amplifier manufacturers. This gain setting improves signal to noise ratio and allows all preceding electronic equipment, including the NX242 TDcontroller or GEO S12 TDController, to operate at optimum level. Remember that using a high gain amplifier will raise the noise floor proportionally.

Operating Mode

Most two channel amplifiers available on the pro-audio market have the following operating modes:

- **Stereo:** two fully independent channels deliver identical power into identical loads
- NEXO recommends Stereo Mode for all amplifier channels feeding RS15's.
- **Bridge-Mono:** the second signal channel processes the same input as the first channel, but with reversed phase. The (single) load is connected between the two positive channel outputs using a suitable connection. While the total output of the amplifier remains the same, the available output voltage, the minimum impedance that can be connected and the voltage gain are doubled as compared with stereo operation. Typically, only channel 1 input is active. Positive and negative output connections vary depending on amplifier manufacturers.
- NEXO does not recommend Bridge Mono Mode unless amplifier power is clearly not sufficient.

IMPORTANT

When in Bridge-Mono mode, check your amplifier user manual for proper connection of outputs 1(+) and (2+) in relation to input phase.

- **Parallel-mono:** the output terminals of the two channels are configured in parallel using an internal relay. The (single) load is connected either to the output of channel 1 or to that of channel 2 (as if in stereo). While the total output of the amplifier remains the same the output voltage level is also the same as in stereo mode. The minimum impedance that can be connected is reduced by half due to the fact that current capability is doubled. Typically, only channel 1 input is active.
- NEXO does not recommend Parallel-Mono Mode for RS15 amplification.

Warning on amplifiers signal processing features

Some high-end amplifiers may include signal processing functions similar to those found in the NX242 TDcontroller or in GEO S12 TDController ("loudspeaker offset integration", "limiter", "compressor," etc.). Moreover, when this processing is digital, computation latency time can introduce a few milliseconds delay from input to output. These functions are not adapted to specific system requirements and may interfere with the complex protection algorithms used in the NX242.

NEXO do not advise using other protection systems in conjunction with the NX242 and they should be disabled.

IMPORTANT

For proper system protection, no latency time or non-linear devices should be inserted between the output of GEO S12 TDController or NX242 TDController and the input of loudspeakers through use of DSP modules such as internal amplifier signal processing.

3.2 RS15 and NXAMP TDControllers

NEXO Powered TDControllers NXAMP 4X1 & 4X4 are integrated solutions for Control and amplification for all NEXO speaker ranges.

NXAMP4x1 and NXAMP4x4 power capability is listed in the table below:

Mode	4 Channels	Bridge Stereo
NXAMP4x1	4 x 650 Watts / 8 Ohms	2 x 1800 Watts / 8 Ohms
	4 x 900 Watts / 4 Ohms	2 x 2600 Watts / 4 Ohms
	4 x 1300 Watts / 2 Ohms	
NXAMP4x4	4 x 1900 Watts / 8 Ohms	2 x 6800 Watts / 8 Ohms
	4 x 3400 Watts / 4 Ohms	2 x 8000 Watts / 4 Ohms
	4 x 4000 Watts / 2 Ohms	

3.2.1 NXAMP connectors

NXAMP4x1 and NXAMP4x4 rear panels feature:

- 4 analog inputs / outputs (links) on XLR3 connectors;
- 4 digital inputs / outputs on RJ45 connectors with optional card;
- 4 speaker level outputs on NL4FC connectors.

Figure below shows connectors implementation on the rear panel.

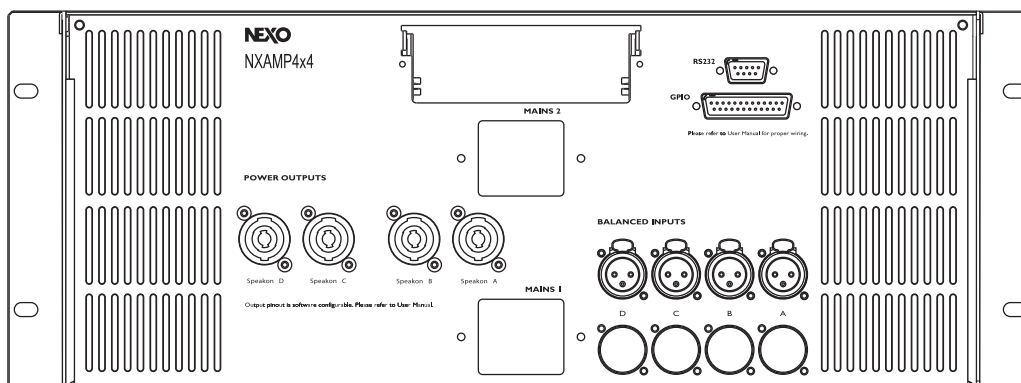

3.2.2 RS15 and NXAMP recommended configurations

	OMNI MODE	DIRECTIONAL MODE
1 x RS15	1 channel of NXAMP4x1 in Bridge Stereo Mode	2 channels of NXAMP4x1 in 4 channels Mode 2 channels of NXAMP4x1 in Bridge Stereo Mode
2 x RS15	2 channels of NXAMP4x1 in Bridge Stereo Mode 1 channel of NXAMP4x4 in 4 channels mode	2 channels of NXAMP4x1 in Bridge Stereo Mode 2 channels of NXAMP4x4 in 4 channels mode
4 x RS15	2 channels of NXAMP4x4 in 4 channels mode	2 channels of NXAMP4x4 in 4 channels mode
8 x RS15	4 channels of NXAMP4x4 in 4 channels mode	4 channels of NXAMP4x4 in 4 channels mode

4 RS15 SETUPS ON NEXO TD CONTROLLERS

4.1 Analogue GEOS12 TDController

GEO S12 TDController parameters have been optimized for 1 x RS15 (omni mode, mono) used in conjunction with 2 x GEO S1210's or 2 Geo x S1230's (mono or stereo).

4.2 Digital NX242-ES4 and NXAMP TDControllers

At RS15 release time (November 2007), 46 setups combining RS15 with NEXO speakers are available in NX242 / NXAMP load 2.43. Please consult www.nexo-sa.com for upgrade releases.

RS15	- 4 x RS15 omni 33Hz-90Hz; - 2 x RS15 cardio 33Hz-90Hz;
PS8	- 2 x RS15 omni 35Hz-90Hz + 2 x PS8 Wideband - 1 x RS15 cardio 35Hz-90Hz + 2 x PS8 Wideband - 2 x RS15 omni 35Hz-90Hz + 2 x PS8 X-Over - 1 x RS15 cardio 35Hz-90Hz + 2 x PS8 X-Over
PS10	- 2 x RS15 omni 35Hz-90Hz + 2 x PS10 Wideband - 1 x RS15 cardio 35Hz-90Hz + 2 x PS10 Wideband - 2 x RS15 omni 35Hz-90Hz + 2 x PS10 X-Over - 1 x RS15 cardio 35Hz-90Hz + 2 x PS10 X-Over
PS15	- 2 x RS15 omni 35Hz-90Hz + 2 x PS15 Passive Wideband - 1 x RS15 cardio 35Hz-90Hz + 2 x PS15 Passive Wideband - 2 x RS15 omni 35Hz-90Hz + 2 x PS15 Passive X-Over - 1 x RS15 cardio 35Hz-90Hz + 2 x PS15 Passive X-Over
GEO S830	- 2 RS15 omni 35Hz-90Hz + 2 S830 Wideband - 1 x RS15 cardio 35Hz-90Hz + 2 x S830 Wideband - 2 RS15 omni 35Hz-90Hz + 2 S830 X-Over - 1 x RS15 cardio 35Hz-90Hz + 2 x S830 X-Over
GEO S805	- 2 RS15 omni 35Hz-90Hz + 2 S805 Wideband - 1 x RS15 cardio 35Hz-90Hz + 2 x S805 Wideband - 2 RS15 omni 35Hz-90Hz + 2 S805 X-Over - 1 x RS15 cardio 35Hz-90Hz + 2 x S805 X-Over
GEO S1230	- 2 RS15 omni 35Hz-90Hz + 2 x S1230 Passive Wideband - 1 x RS15 cardio 35Hz-90Hz + 2 x S1230 Passive Wideband - 1 x RS15 cardio 35Hz-90Hz + 1 x S1230 Active Wideband - 2 RS15 omni 35Hz-90Hz + 2 x S1230 Passive X-Over - 1 x RS15 cardio 35Hz-90Hz + 2 x S1230 Passive X-Over - 1 x RS15 cardio 35Hz-90Hz + 1 x S1230 Active X-Over
GEO S1210	- 2 RS15 omni 35Hz-90Hz + 2 x S1210 Passive Wideband - 1 x RS15 cardio 35Hz-90Hz + 2 x S1210 Passive Wideband - 1 x RS15 cardio 35Hz-90Hz + 1 x S1210 Active Wideband - 2 RS15 omni 35Hz-90Hz + 2 x S1210 Passive X-Over - 1 x RS15 cardio 35Hz-90Hz + 2 x S1210 Passive X-Over - 1 x RS15 cardio 35Hz-90Hz + 1 x S1210 Active X-Over

5 CONNECTION DIAGRAMS

5.1 RS15 with GEOS12 TDController (Mono Omni Mode)

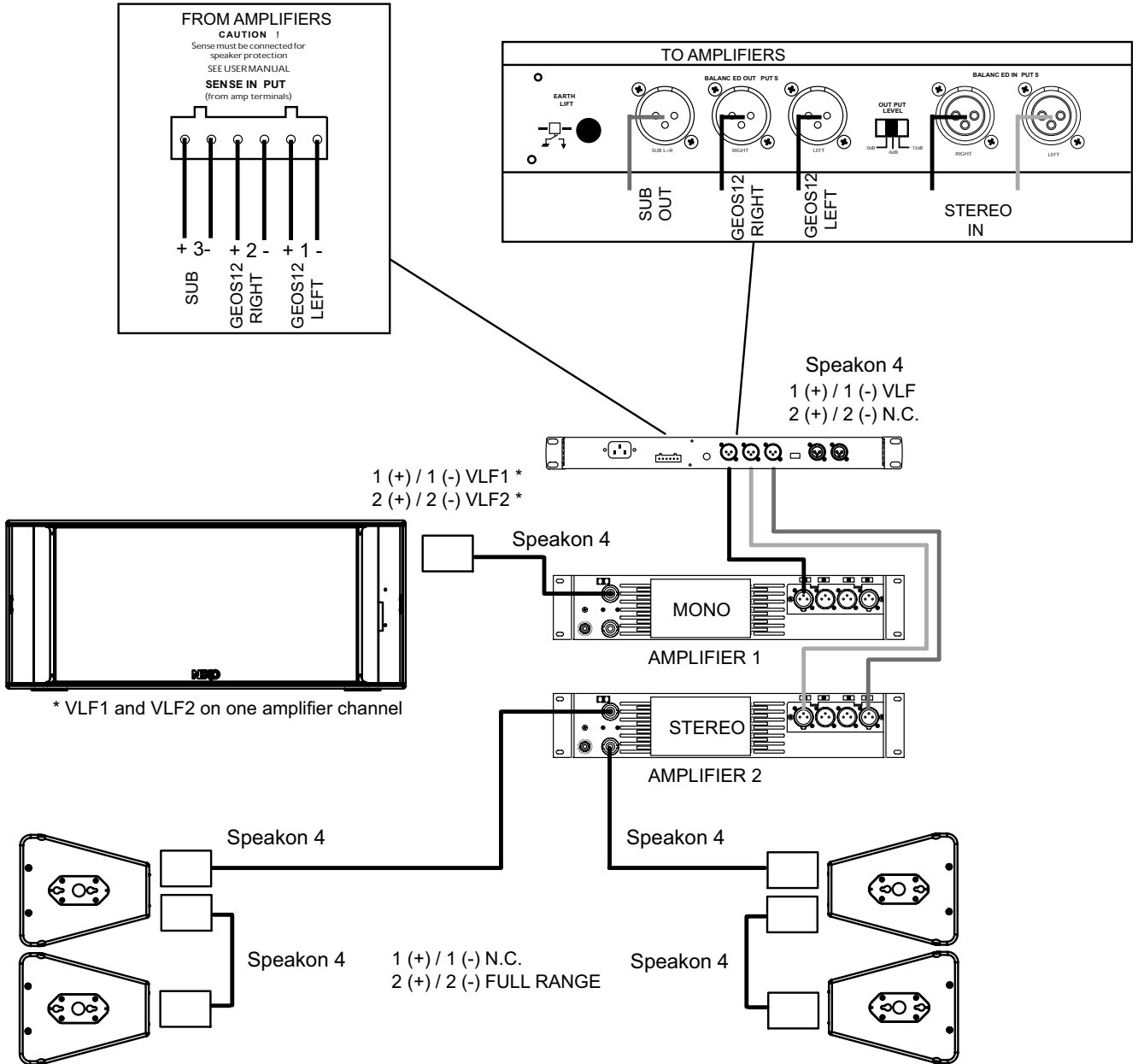

5.2 RS15 with NX242-ES4 TD Controller (Stereo Omni Mode)

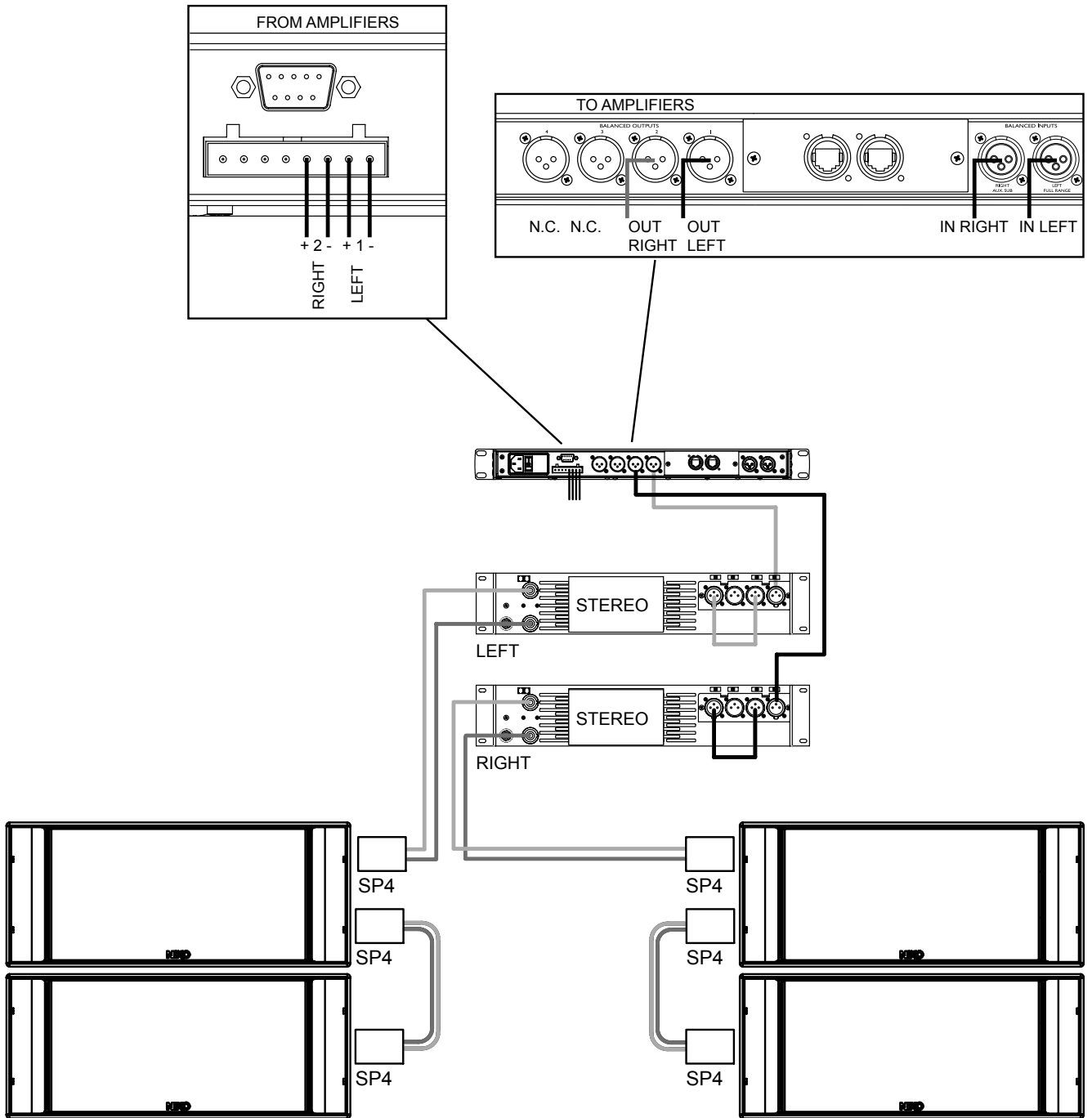

5.3 RS15 with NX242-ES4 TD Controller (Stereo Directional Mode)

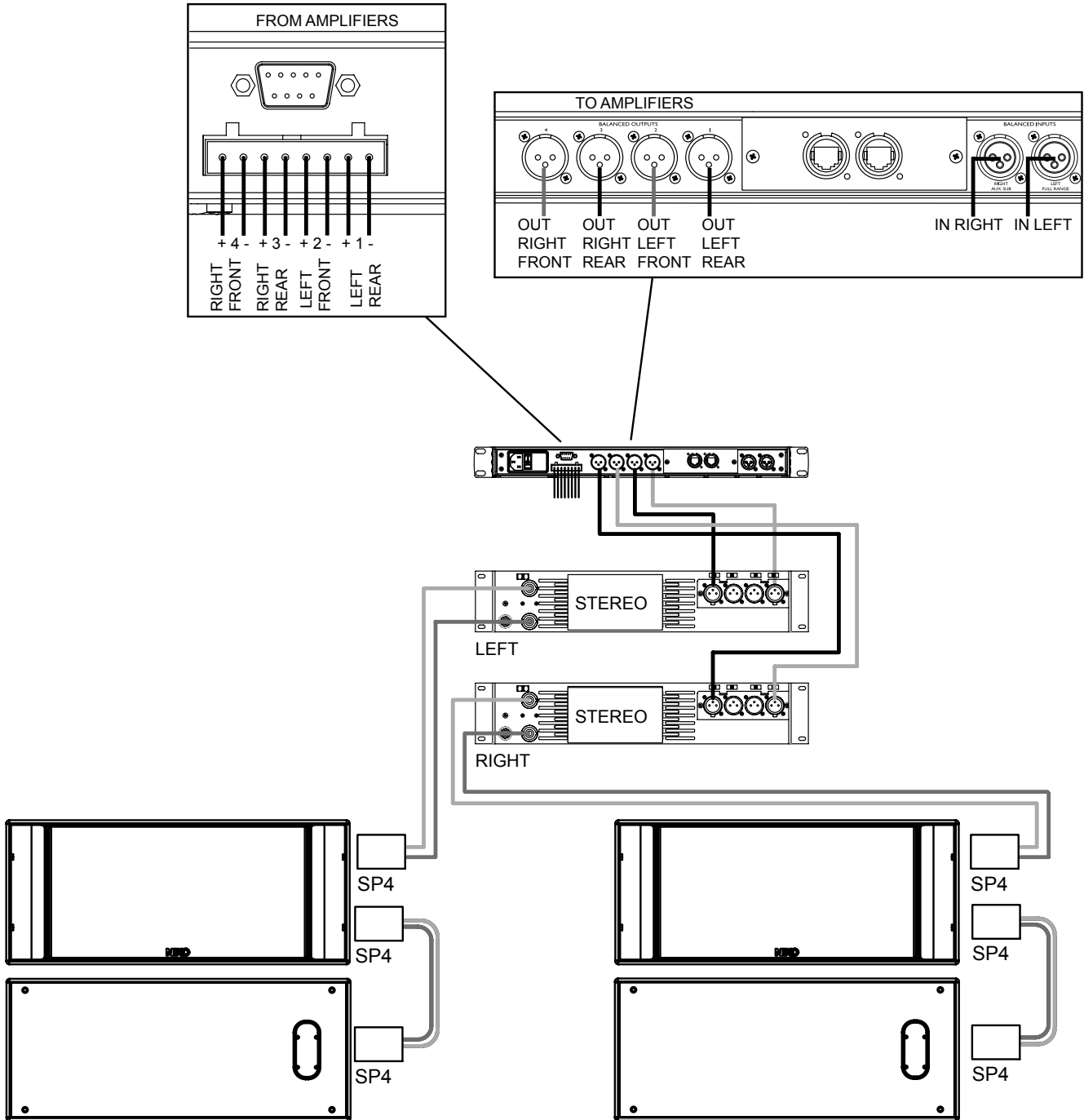

5.4 RS15 with NXAMP (Stereo Omni Mode)

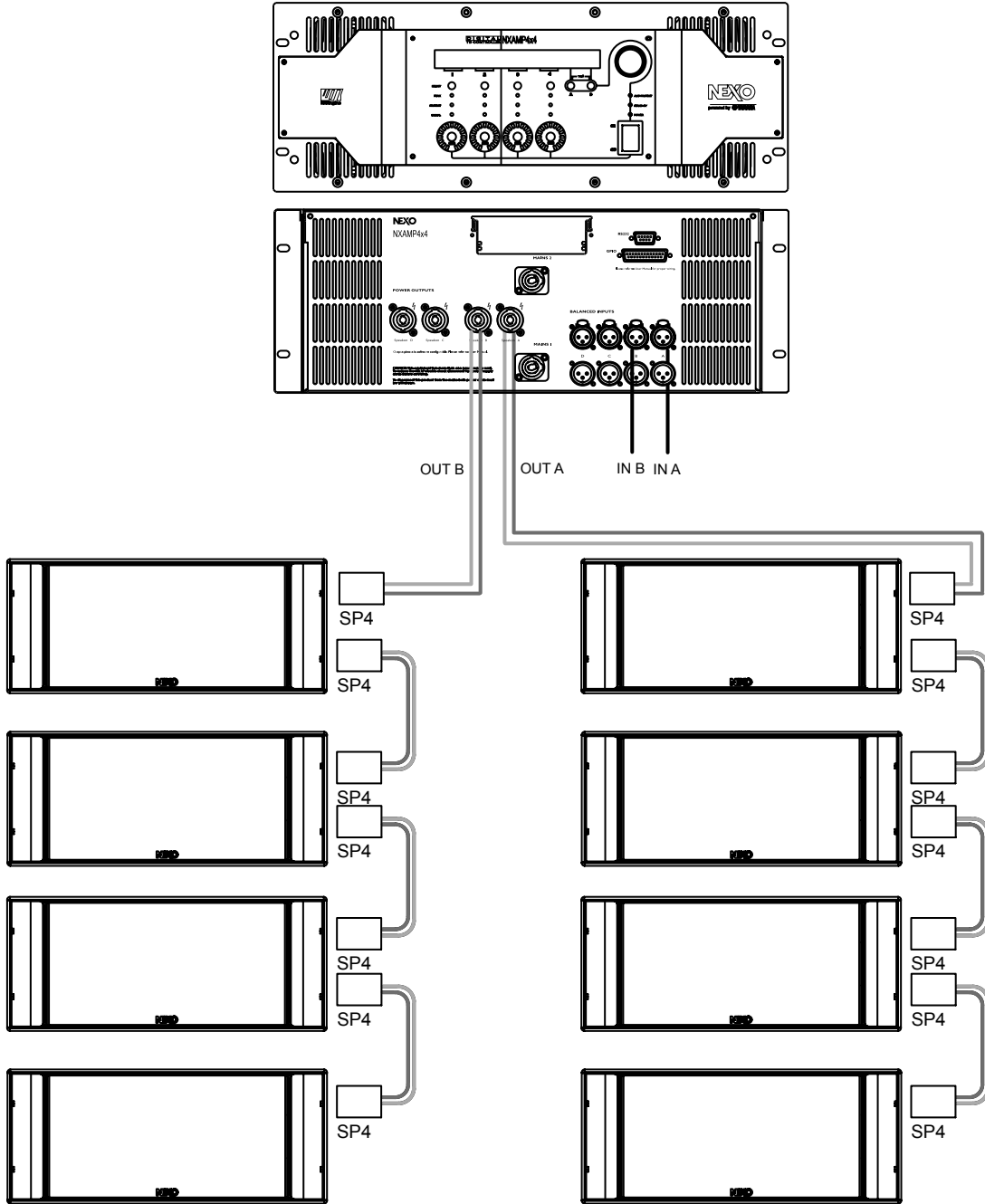

5.5 RS15 with NXAMP (Stereo Directional Mode)

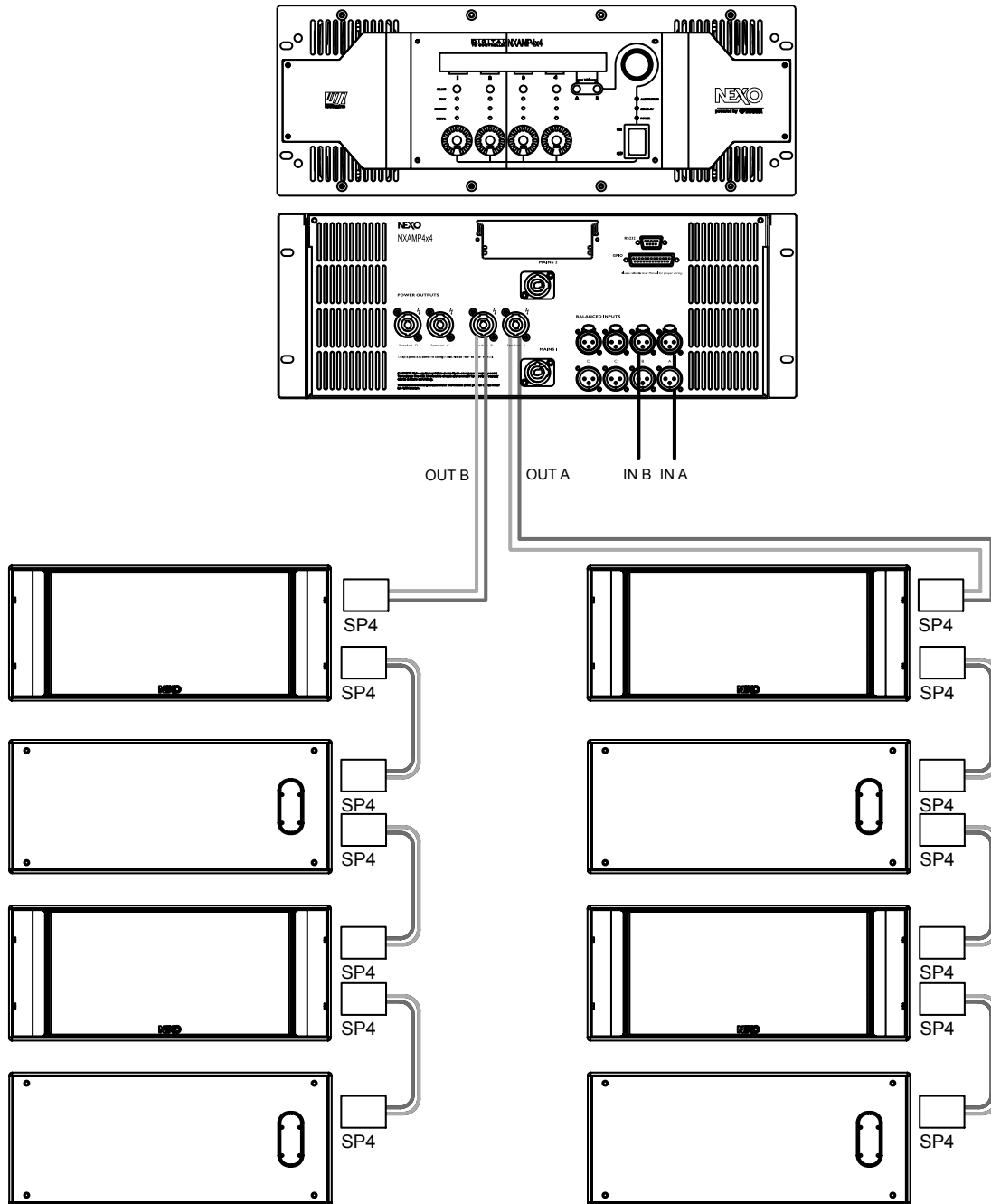

6 RS15 RIGGING INSTRUCTIONS

Before proceeding with assembly of RS15 arrays, please ensure that the components are present and undamaged. A component list is appended to this manual. In the event of any shortage, please contact your supplier.

For maximum efficiency the RS15 rigging system requires three experienced persons for set-up: typically one motor hoist operator, and one RS15 operator per side of the array. Good synchronisation and crosscheck between the operators are key elements for a reliable and safe set-up.

6.1 SAFETY FIRST

RS15 Rigging System structural computations and related documents are available in Geosoft2 or at Nexo (info@nexo.fr) upon request.

We include this section to remind you of safe practice when flying the RS15 system. Please read it carefully. However, user must always apply his or her knowledge, experience and common sense. If in any doubt, seek advice from your supplier or NEXO agent.

This manual offers guidance only for RS15 RAYSUB systems. References in this manual to other rigging equipment such as motor hoists, steels, shackles etc. are made to clarify the description of RS15 procedures. The user must ensure that operators are properly trained by other agencies in the use of these items.

The RS15 Rigging System has been optimised for the deployment of vertical arrays of RS15 loudspeakers. No angle adjustment is allowed between cabinets.

The RS15 Rigging System is a professional precision tool set, and should be handled with extreme care. Only persons who are fully conversant with the operation of the RS15 Rigging System and provided with suitable safety equipment should deploy RAYSUB Arrays. Misuse of the RS15 Rigging System could lead to dangerous consequences.

Used and maintained correctly, the RS15 Rigging System will give many years of reliable service in portable systems. Please take the time to read and understand this manual.

6.1.1 Flown Systems Safety

- Always inspect all the rigging components and cabinets for damage before assembly. Pay special attention to the lifting points, and safety clips. If you suspect that any of the components are damaged or defective, DO NOT USE THE AFFECTED PARTS. Contact your supplier for replacements.
- Read this manual carefully. Also be familiar with the manuals and safe working procedures for any ancillary equipment that will be used with the RS15 Rigging System.
- Ensure that all local and National regulations regarding the safety and operation of flying equipment are understood and adhered to. Information on these regulations can usually be obtained from Local Government Offices.
- When deploying a RS15 system always wear protective headwear, footwear and eye protection.
- Do not allow inexperienced persons to handle a RS15 system. Installation personnel should be trained in loudspeaker flying techniques and should be fully conversant with this manual.
- Ensure that motor hoists, hoist control systems and ancillary rigging components are currently certified as safe and that they pass a visual inspection prior to use.
- Ensure that the public and personnel are not allowed to pass beneath the system during the installation process. The work area should be isolated from public access.
- Never leave the system unattended during the installation process.
- Do not place any object, no matter how small or light, on top of the system during the installation procedure. The object may fall when the system is flown and is likely to cause injury.

- Secondary safety steels must be installed once the system has been flown to the operating height. Secondary steels must be fitted irrespective of requirements of the local safety standards applicable to the territory.
- Ensure that the system is secure and prevented from pivoting around the motor hoist.
- Avoid any form of excessive dynamic loading to the assembly (structural computations on RS15 Rigging System are based on a 1/1.2 factor for hoist or motor acceleration).
- NEVER attach any item to the RS15 system other than the RS15 accessories.
- When flying outdoor systems ensure that the system is not exposed to excessive wind or snow loads and is protected from rainfall.
- The RS15 Rigging System requires regular inspection and testing by a competent test centre. NEXO recommend that the system is load tested and certified annually or more frequently if local regulations require.
- When de-rigging the system ensure that the same duty of care is given to the procedure as for the installation. Pack RS15 components carefully to prevent damage in transit.

6.1.2 Ground Stacking Safety

Statistically, many more injuries occur due to unstable ground stacked PA systems than those associated with flown systems. There are several reasons for this fact, however the message is clear:

- Always survey the supporting structure upon which a ground stack is to be built. Always look beneath PA wings to inspect the deck support and if necessary ask for the stage scrims and dressings be removed to allow access.
- If the stage surface slopes, as it does in some theatres, ensure that the system is prevented from sliding forwards due to vibration. This may require the fitting of timber battens to the stage floor.
- For outdoor systems ensure that that the system is protected from wind forces which might cause the ground stack to become unstable. Wind forces can be huge, especially upon large systems, and should never be underestimated. Observe meteorological forecasts, calculate the “worst case” effect upon the system prior to erection and ensure that the system is secured appropriately.
- Take care when stacking cabinets. Always employ safe lifting procedures and never attempt to build stacks without sufficient personnel and equipment.
- Never allow anyone, whether operators, artists or members of the public to climb onto a ground stacked PA system. Anyone who needs to climb over 2m (6 ft) high should be fitted with suitable safety equipment including a clip-on harness. Please refer to local Health and Safety legislation in your territory. Your dealer can help with advice on access to this information.
- Apply the same attention to all safety matters when de-stacking systems.
- Be aware that safety procedures are as important in the truck and in the warehouse as they are at the venue.

IMPORTANT

- All RS15 Accessories are specifically rated in agreement with structural computations.
- Never use other accessories - including push-pins - when assembling RS15 cabinets than the ones provided by NEXO: NEXO will decline responsibility over the entire RS15 accessory range if any component is purchased from a different supplier.

6.1.3 Contacts

Correct training is fundamental to safe practise when working with loudspeaker flying systems. NEXO recommend that users contact local industry associations for information on specialist courses.

Information for International training agencies can be obtained by contacting either:

The Production Services Association
(PSA),
School Passage,
Kingston-upon-Thames,
KT1 SDU Surrey,
ENGLAND
Telephone: +44 (0) 181 392 0180

Rigstar Training and Testing Center
82 Industrial Dr. Unit 4
Northampton, Massachusetts 01060 U.S.A.
Phone: 413-585-9869 -- Fax: 413-585-9872
school@rigstar.com

ESTA
Entertainment Services & Technology Association
875 Sixth Avenue, Suite 1005
NEW YORK, NY 10001 USA
Phone: 212-244-1505 – Fax: 212-244-1502
info@esta.org

6.2 Flying RS15 arrays

IMPORTANT

- Maximum allowed RS15 quantity to be flown is 12;
- RS15 bumper rigging point must be adjusted so that bumper always remains horizontal;
- RS15 flying system forbids angles between adjacent cabinets.

IMPORTANT

RS15 bumper is designed to be flown from one rigging point only.
Motor hoist must be rated to support entire cluster weight.

Required items

- 1 x Bumper (RS15-BUMPER);
- N Pair of RS15 Rigging Plates (RS15-FPLATES) for N cabinets;
- 4xN Quick release pins (BLGEOS) for N cabinets;
- 1 hoist (not provided).

6.2.1 Hoist Rating

N being RS15 quantity within cluster, cluster weight is given by:

$$W_{\text{cluster}} = (17\text{kg}/38\text{lbs}) + N \times (70\text{kg}/154\text{lbs})$$

NB: this formula includes cable weight up to 5kg/11lbs per RS15

Typical cases are:

- 3 RS15 cluster = ¼ ton hoist;
- 6 RS15 cluster = ½ ton hoist;
- 12 RS15 cluster = 1 ton hoist.

6.2.2 Connecting first RS15 to bumper

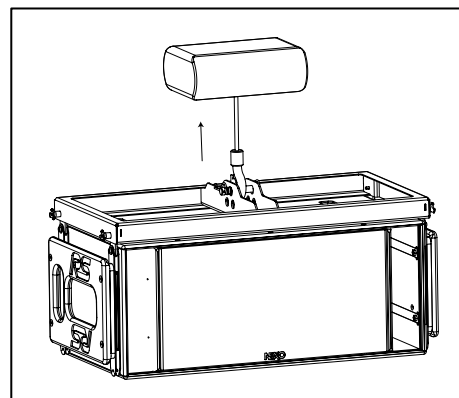
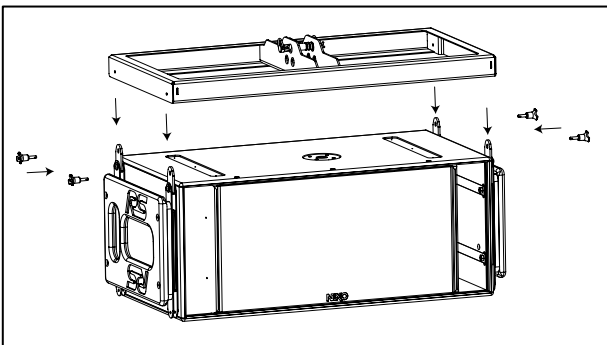

- Connect bumper to first RS15 flying system link plates; ensure quick release pins are properly locked;
- Insert axis in center hole and secure it with provided "R" clips;
- Connect hoist hook to bumper axis and lift assembly so that RS15 is off the ground.

6.2.3 Adjusting rigging point for horizontality

Before connecting a second cabinet, bumper angle has to be adjusted for perfect horizontality.

This requires that the rigging point is adjusted in the two horizontal directions so that the bumper remains horizontal within $\pm 1^\circ$. Adding cabinets will reduce this tolerance.

Adjusting 0° along the cabinet depth

Adjusting horizontality along cabinet depth is done by properly selecting bumper hole:

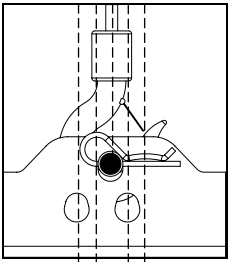
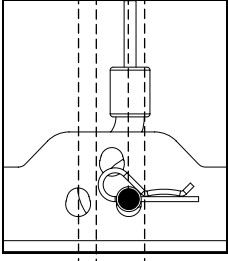
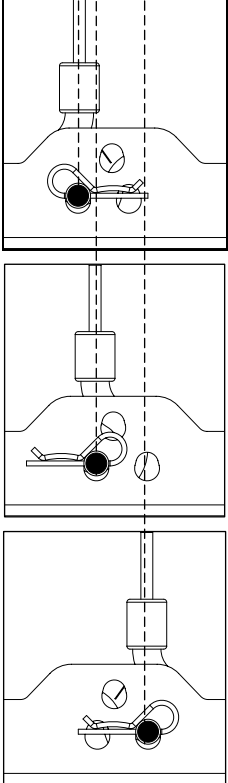
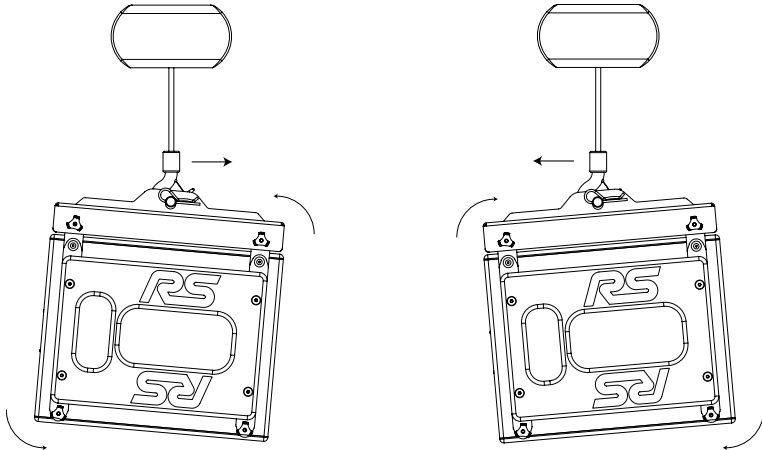
Case Description	
	<p><u>Top center bumper rigging point centered geometrically (0mm):</u></p> <ul style="list-style-type: none"> - RS15 equipped with wheels clusters (gravity center of a single RS15 with wheels precisely matches geometrical center); - RS15 alternate clusters (speakers facing alternatively left and right, with or without wheels, gravity center always matches geometrical center).
	<p><u>Top center bumper rigging point 17mm ahead of geometrical center:</u></p> <ul style="list-style-type: none"> - RS15 without wheels clusters (all speakers facing same direction, gravity center of a single RS15 is precisely 17mm ahead of geometrical center).
	<p><u>Other available rigging point positions:</u></p> <p>Cable weight influence over gravity center position cannot be precisely anticipated. Additional rigging point configurations are available so that the RS15 bumper is always set horizontally. These rigging point positions are:</p> <ul style="list-style-type: none"> - 34mm behind geometrical center; - 17mm behind geometrical center (<i>requires flipping the bumper horizontally</i>); - 34mm ahead geometrical center (<i>requires flipping the bumper horizontally</i>). <div style="text-align: center;">  </div>

Adjusting 0° along the cabinet width

Adjusting horizontality along cabinet depth is done by properly adjusting the bumper axis as described in drawings below:

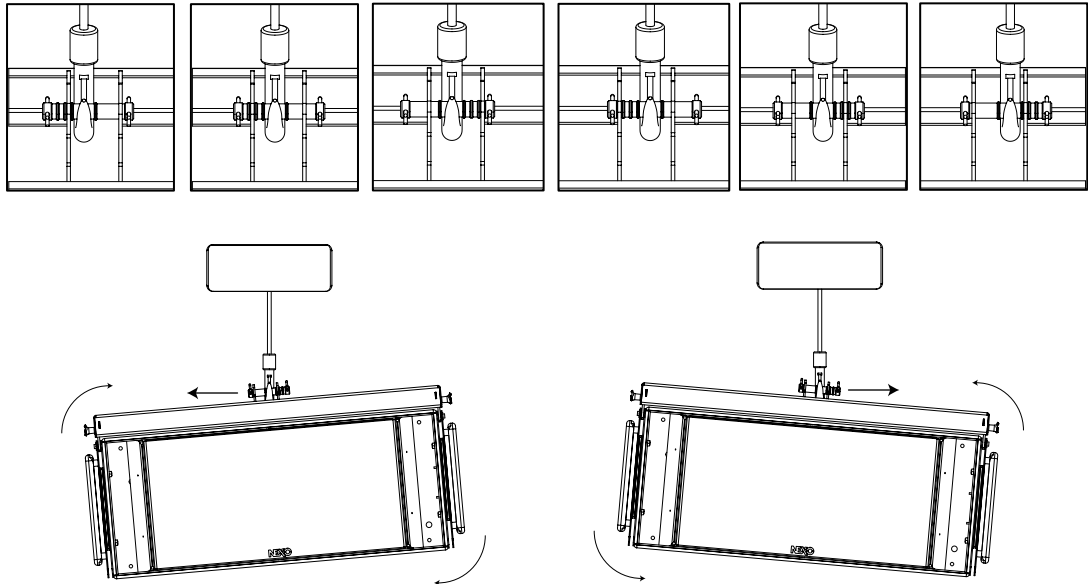

Do not forget to secure the axis with "R" clips once horizontality is achieved. Assembly is now ready for second RS15 connection.

6.2.4 Flying the second RS15

- Lift assembly to sufficient height in order to connect a second RS15;
- Connect second RS15 to first RS15 flying system link plates; ensure quick release pins are properly locked;

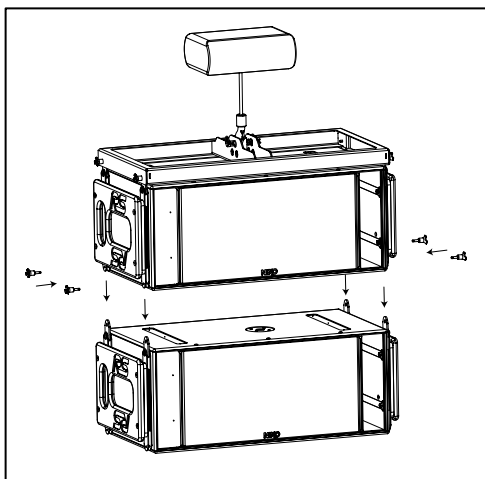

OMNI MODE

DIRECTIONAL MODE / BACK TO BACK /

DIRECTIONAL MODE / FACE TO FACE

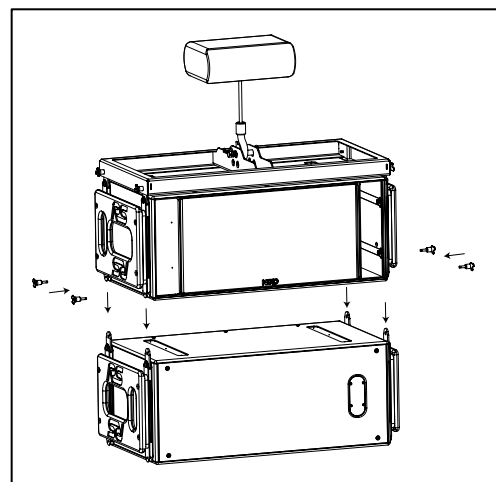

DIRECTIONAL MODE / ALTERNATE

6.2.5 Flying subsequent RS15's

- Repeat above steps for subsequent RS15's
- Lift cluster defined rigging height, secure cluster horizontally to prevent it from rotating;

IMPORTANT

Do not attempt to make any change to the bumper rigging point once the cluster is lifted

- Secure bumper with secondary safety steel.

IMPORTANT

The requirements for secondary safety systems vary with territories. However, the secondary safety steel **MUST** have a SWL equivalent or greater than that of the rigging system

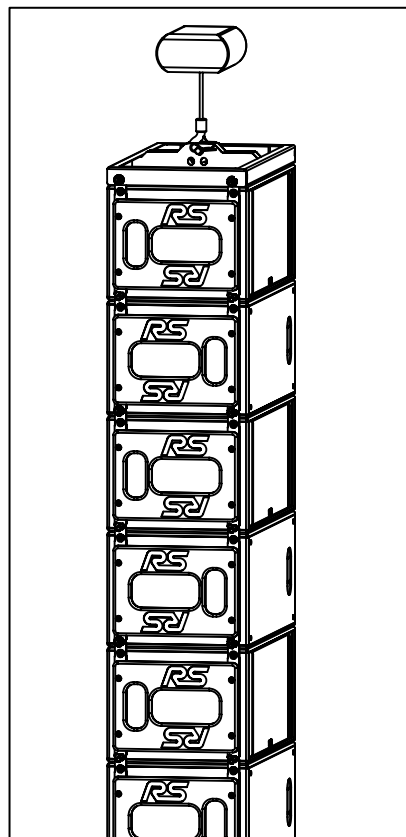
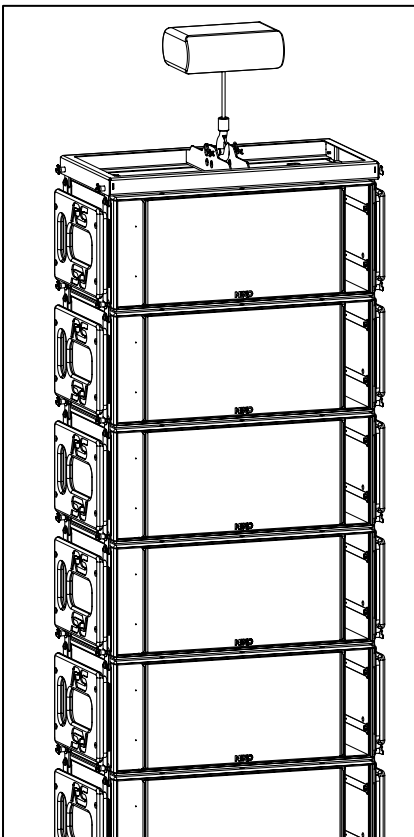
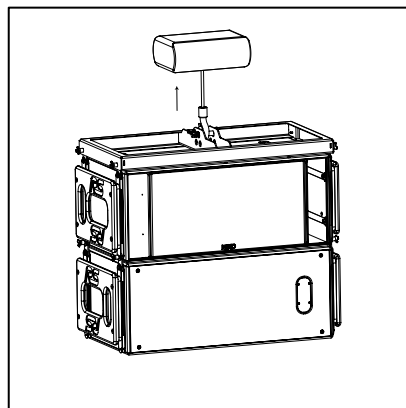
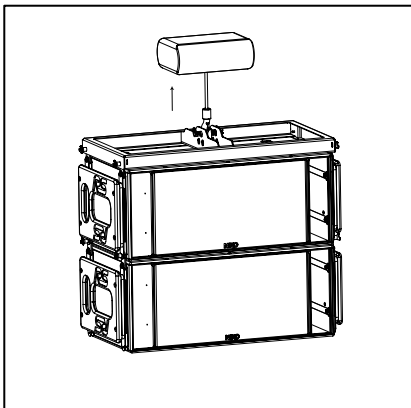

6.3 Testing and Maintenance of the RS15 flying system

- General: please keep regular maintenance attention to the RS15 flying system in order to provide long and reliable service. NEXO recommends regular testing of loudspeaker rigging components, preferably using a suitable test rig coupled with a visual inspection.
- Fasteners: there are several critical points in the RS15 cabinets; primary concerns are:
 - the grid screws attaching the grid to the cabinet;
 - the screws attaching the connecting plates to the cabinet.
- These fasteners should be regularly checked and tightened as necessary.
- Cleaning: The exterior of the cabinet and the rigging system can be cleaned with a damp cloth soaked in mild soapy water. On no account use solvent based cleaners , which may damage the finishing of the cabinet
- After cleaning, the rigging system must be treated with a suitable lubricant to prevent rusting. NEXO recommends the use of Scottoil FS365 or equivalent which is a water-based lubricant with a mixture of machine oil, surfactant and anti-rust treatment.

7 GENERAL GUIDELINES FOR SUBWOOFER DESIGN

7.1 Low Frequency Issues

Even low frequency coverage is amongst the toughest issues in sound system design. Common issues that are faced in design are as follow:

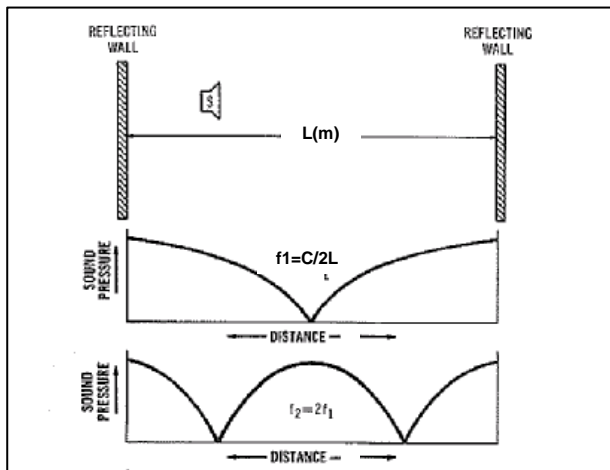
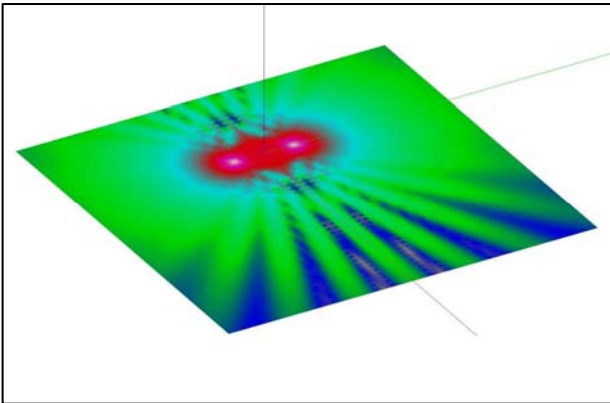
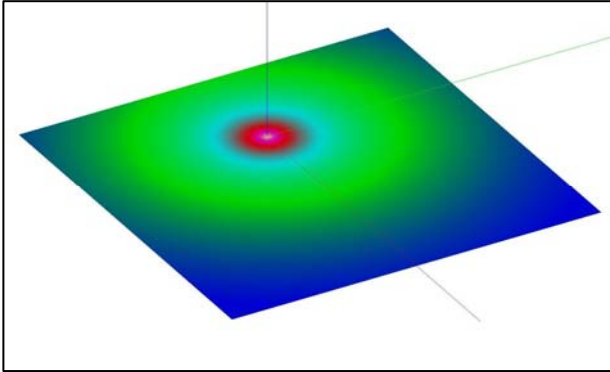

- Low frequency radiation is hard to control efficiently because of wavelength becoming large (10m / 30ft at 34 Hz) in relation to sources; and most of available subwoofers are omnidirectional; this results in important low frequency feedback on stage, environmental problems in outdoor venues and increased reverberation time in indoor venues;
- Stereophonic implementation of subwoofers introduces very strong interference patterns; these are related to Left and Right path length difference to listener location while pressure levels are comparable for Left and Right arrays; while always maximum at the center – where distance to Left and Right arrays are equal –, pressure level can severely drop at locations where path length equals half the wavelength of frequency of interest. This effect is well-known from audio-engineers, and often referred to as “Power Alley”;
- In closed venues, room eigen modes (nulls and max) are dominant over source location; because these modes depend on accurate characterization of boundary surfaces (walls, ceiling, floor), audience coverage is very hard to predict.

To overcome these difficulties, some common sense rules can help.

7.2 Gradient Subwoofers benefits

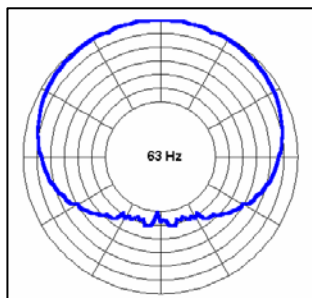

Gradient subwoofers can provide up to 15 dB front to rear average attenuation (Please refer to Ray Sub technical note for in-detail explanation on gradient subwoofers).

Low frequency level on stage is therefore significantly reduced on stage, and in the neighbouring environment in open air venues.

Because of their directional pattern, Gradient subwoofer are also less sensitive to room eigen modes.

7.3 Monophonic Design

Left and Right subwoofer arrays can be merged into a monophonic system so that interferences no longer exist.

When using few cabinets, this can be done by installing these cabinets at the centre front stage. If cabinets are set on the ground in front of the stage, level discrepancy from first to last rows will be important. Flying cabinets above centre stage will reduce first to last rows discrepancies significantly.

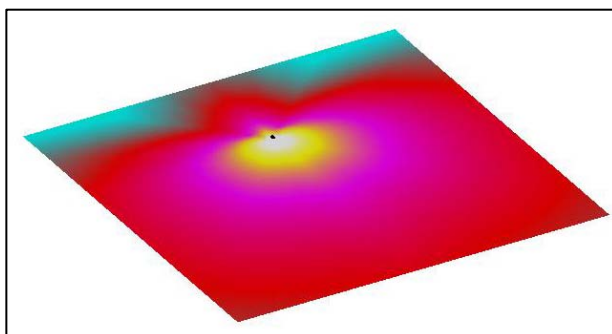

CENTRE STACKED DIRECTIONAL SUBWOOFER

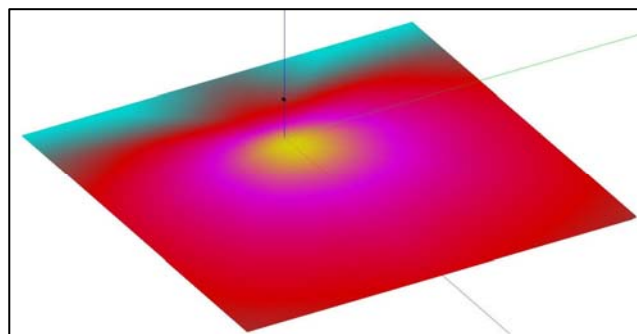

CENTRE FLOWN DIRECTIONAL SUBWOOFER

When using a larger amount of cabinets, these can then be installed all across the stage provided distance between units does not exceed half the wavelength of the upper frequency limit (1.7m/5.6ft at 100 Hz). Array coverage can then be adjusted geometrically (by curving the array horizontally so that it matches the audience area, which creates an asymmetrical front stage to rear stage pattern with a "hot" point on stage) or electronically (by implementing a delay that increase from the centre to the sides, which creates a symmetrical pattern front to rear). In both cases, omnidirectional subwoofers should be avoided so low frequency that level on stage does not exceed level in the audience.

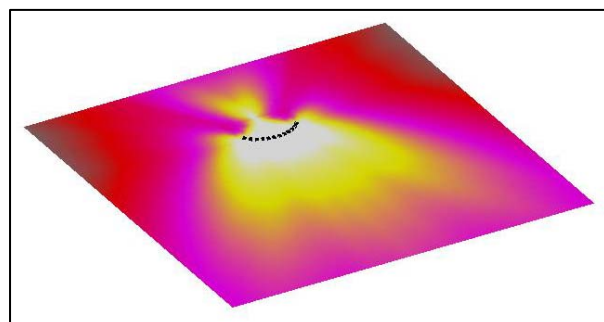

CURVED SUBWOOFER ARRAY ACROSS STAGE

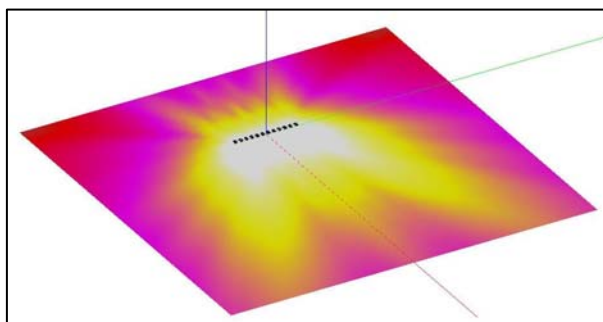

STRAIGHT DELAYED SUBWOOFER ARRAY ACROSS STAGE

Main drawback of monophonic designs as the ones described above is inconsistent phase relationship between subwoofer arrays and main systems over the audience area (lack of impact in the 80Hz-125Hz bandwidth).

7.4 Stereo Design

If stereophonic implementation has to be maintained, then Left and Right array coverage patterns have to be as independent as possible – ie coverage overlap from Left to Right has to be minimized.

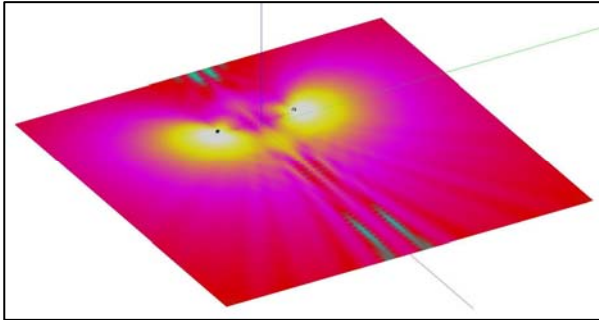

When using few cabinets, minimizing overlap can only be achieved with directional devices by rotating the subwoofers 30° to 45° outwards (rotating an omnidirectional subwoofer makes no difference in the coverage pattern).

When using a larger amount of cabinets, Left and Right subwoofers arrays must be designed so that level drops as much as possible inwards, and is maintained as going outwards. Therefore, main axis efficiency must be orientated outwards (through use of delays or curving the array outward as in below figure). Such arrays must be experimented playing one side only to check if above condition is fulfilled, and then summed left and right for interference evaluation (see below drawings). Although pressure level will still drop in the centre vicinity, overall level in the audience area is comparable to what occurs at the centre.

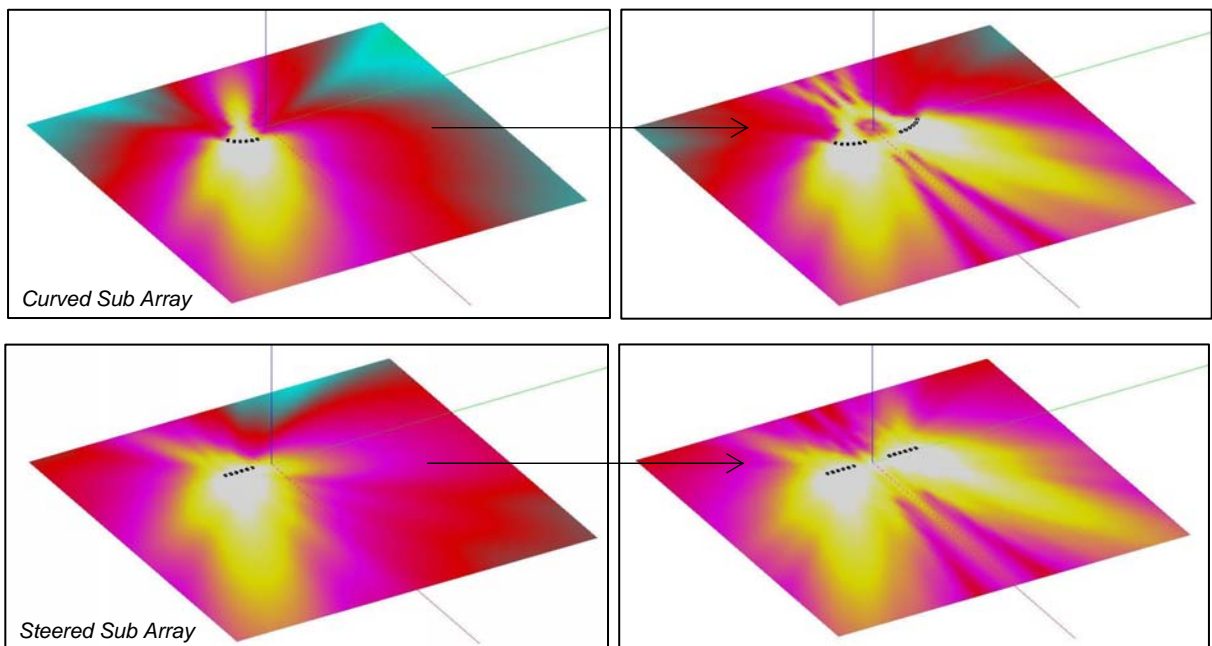

LEFT IMPLEMENTATION MINIMIZING RIGHT COVERAGE

LEFT AND RIGHT SUM

Advantage of stereo design as oppose to mono design is much improved phase relationship between subwoofer arrays and main systems since distance between them is greatly reduced.

However, it is essential to keep in mind that stereo subwoofer array design always leads to strong interferences in the centre alley vicinity (a couple of steps left and right of mixing position).

A successful design requires minimizing the audience area over which these interferences occur, and therefore lots of on-site experimentation.

8 RAY SUBS IMPLEMENTATION

8.1 Omnidirectional Mode

8.1.1 Single RS15

Omnidirectional Mode implementation should be favoured in configurations where:

- sufficient depth is not available for directional implementation (proscenium, front stage etc...);
- strong rear radiation is not critical.

Although wide in both cases, coverage is slightly narrower along RS15's width than height (see drawings below).

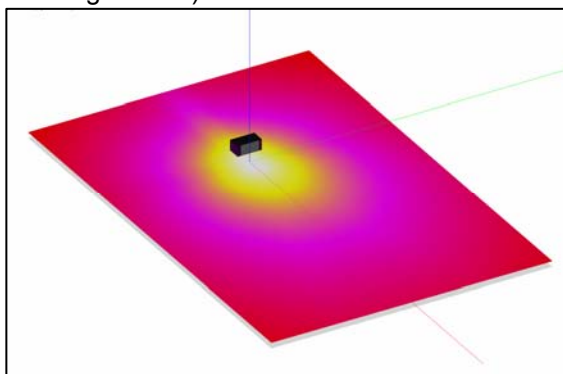

HORIZONTAL COVERAGE IN OMNI MODE (100 HZ)

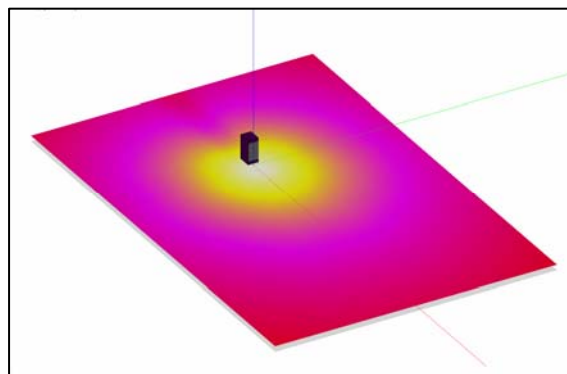

VERTICAL COVERAGE IN OMNI MODE (100 HZ)

8.1.2 RS15 arrays

IMPORTANT

RS15s arrays must be installed with bumper set horizontally and all cabinets at 0°.

Design procedure should be in agreement with what has been described in the preceding section.

See following section on Steered Arrays

8.2 Directional Mode

IMPORTANT

RS15 can be installed "Left" or "Right" (see section 2.1):

- "Left" means grid is Left when looking from front;
- "Right" means grid is right when looking from front.

Whenever possible, NEXO recommends symmetrical designs.

8.2.1 Single RS15

Single RS15 have an asymmetrical pattern in the horizontal plane (ie speakers on the side), which is tilted 30° off-axis towards speakers direction; vertical pattern (ie speakers facing up or down) is symmetrical).

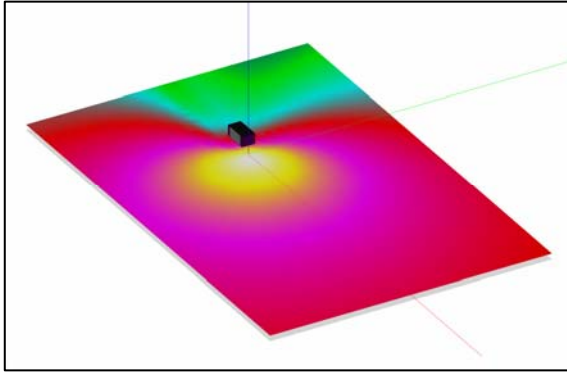

HORIZONTAL COVERAGE IN DIRECTIONAL MODE (100 HZ)

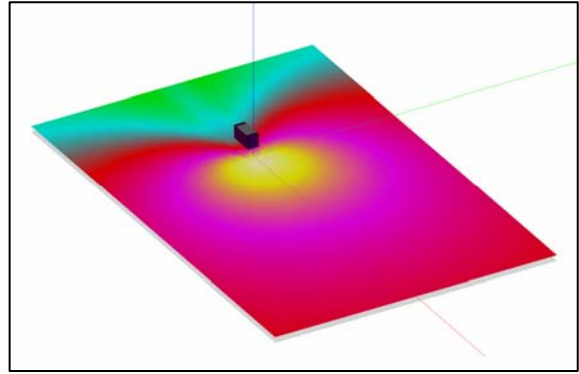

VERTICAL COVERAGE IN DIRECTIONAL MODE (100 HZ)

IMPORTANT

So that directional behaviour and acoustic load are not altered, no reflecting surface should be at less than 50cm (20") from the RS15 side walls and drivers.

In case of stereo configurations, NEXO recommends that speaker side is set outwards to minimize interference region in stereo designs (ie "RS15s LEFT" should be installed Left and "RS15s RIGHT" should be installed Right).

8.2.2 RS15s pair

There are three ways of using pairs of RS15s in directional mode: "alternate", "back to back" and "face to face" (50cm / 20" between grids)

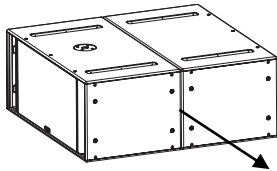

"BACK TO BACK" CONFIGURATION

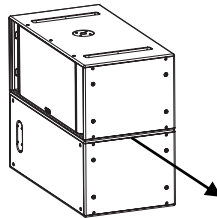

"ALTERNATE" CONFIGURATION

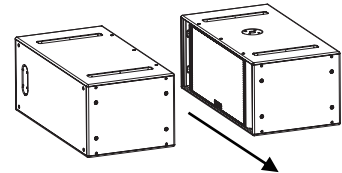

"FACE TO FACE" CONFIGURATION

All of these configurations have symmetrical patterns with a smooth 15dB attenuation at the rear over the entire RS15 bandwidth, but significantly different horizontal coverage.

- "back to back" configuration has a -3dB coverage which decreases from 120° at 31.5 Hz to 60° at 100Hz;
- "alternate" configuration has a constant -3dB coverage of 120° from 31.5Hz to 100Hz;
- "face to face" configuration has a -3 dB coverage which increases from 120° at 31.5 Hz to 180° at 100 Hz.

Detailed coverage information on these configurations is available in section 9.3.2 of this manual.

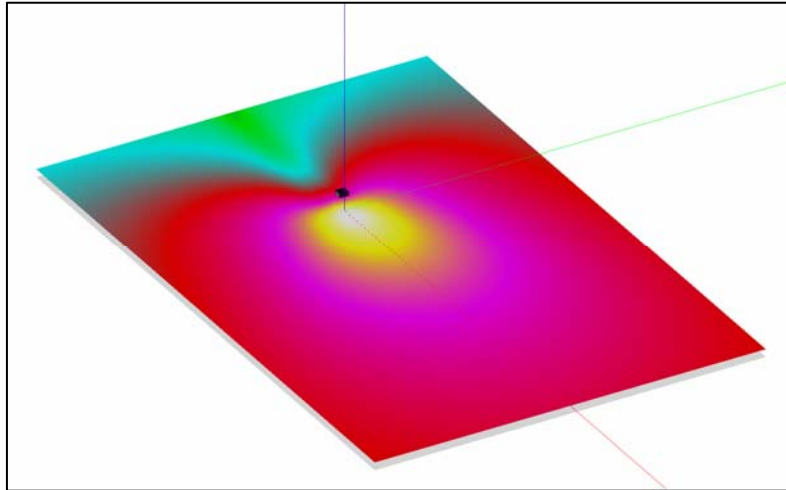

"BACK TO BACK" CONFIGURATION AT 100 HZ

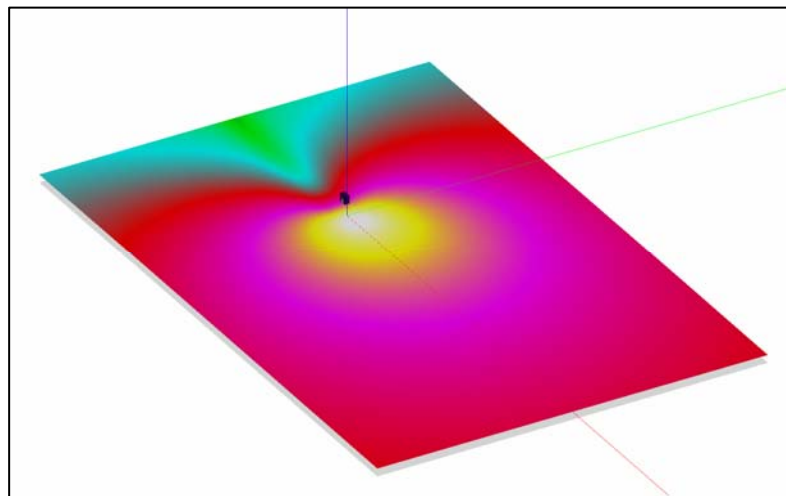

"ALTERNATE" CONFIGURATION AT 100 HZ

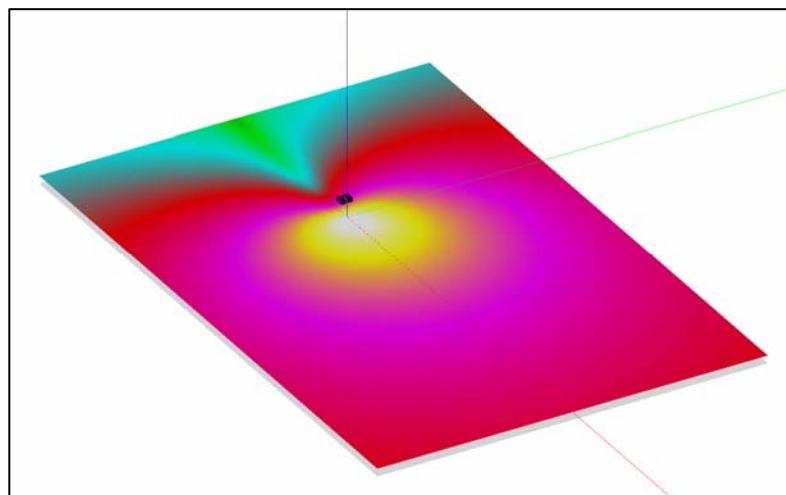

"FACE TO FACE" CONFIGURATION AT 100 HZ

8.2.3 RS15s arrays

IMPORTANT

RS15s arrays must be installed with bumper set horizontally and all cabinets at 0°.

Flying RS15s columns can significantly improve low frequency coverage in the vertical plane, and therefore over audience depth provided height is sufficient.

A 12 RS15 cluster flown at 10m/30ft will provide a +/- 3dB pressure level deviation at 100Hz over an audience area 75m/200ft deep while maintaining 15 to 20dB attenuation on stage (see figure below).

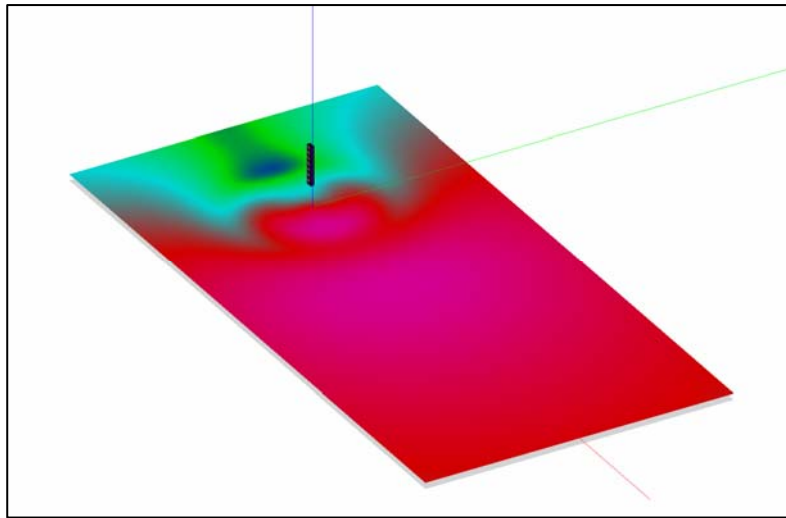

12 RS15 "ALTERNATE" CLUSTER OVER 75M/200FT

8.3 Steered RS15s arrays

8.3.1 Steering technique

RS15s arrays must be flown vertically with bumper set horizontally and all cabinets at 0°.

Coverage adjustments can be efficiently implemented through the "steering" technique, which consists in implementing delays in cabinets to tilt coverage up or down.

IMPORTANT

- "Steering" techniques should not be applied to clusters of less than 4 RS15;
- Coverage control through steering technique increases with cluster height.

Steering can be applied by group of 2, 3 or 4 RS15s in Omni Mode as well as in Directional Mode.

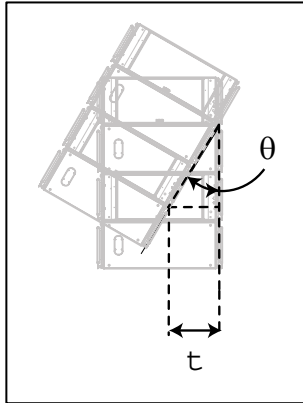

GROUP OF 2 RS15S STEERING

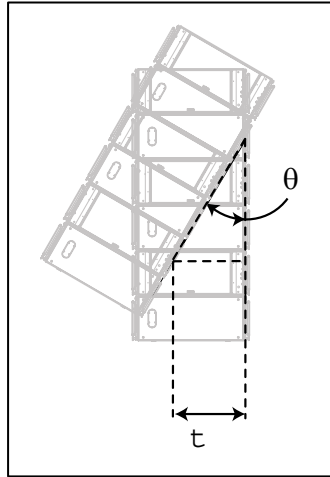

GROUP OF 3 RS15S STEERING

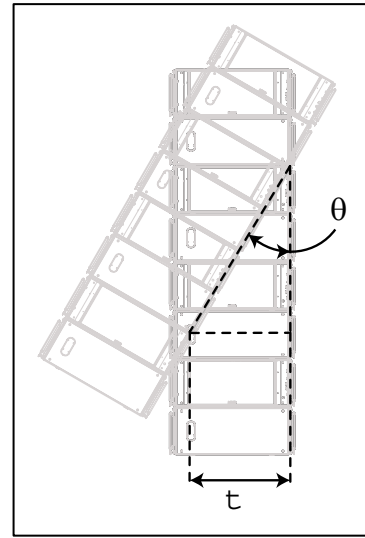

GROUP OF 4 RS15S STEERING

“Steering” delays values for the pairs can easily be computed according to following formula:

$$\tau = h \cdot \sin(\theta) / C \quad (\text{metric})$$

τ is the value to be applied to the second pair

h is the height of tilted elements (0.91m for 2 RS15s, 1.365m for 3 RS15s, 1.82m for 4 RS15s)

C is the speed of sound (= 343m/s)

8.3.2 Delay values implementation

- If the coverage is to be tilted down, then top group delay should be set at 0ms and delay should progressively increase on lower groups.
- If the coverage is to be tilted up, then lower group delay should be set at 0ms and delay should progressively increase on upper pairs.
- Delay value for first group is always 0ms.
- Delay value for second group is τ
- Delay values for subsequent groups are 2τ , 3τ etc...

Table below lists these values for typical angle values:

TILT ANGLE		0°	5°	10°	15°	20°	25°	30°	35°	40°	45°
GROUP 2 RS15s	DELAY τ (ms)	0.0	0.2	0.5	0.7	0.9	1.1	1.3	1.5	1.7	1.9
	DISTANCE (cm)	0.0	7.9	15.8	23.6	31.1	38.5	45.5	52.2	58.5	64.3
GROUP 3 RS15s	DELAY τ (ms)	0.0	0.3	0.7	1.0	1.4	1.7	2.0	2.3	2.6	2.8
	DISTANCE (cm)	0.0	11.9	23.7	35.3	46.7	57.7	68.3	78.3	87.7	96.5
GROUP 4 RS15s	DELAY τ (ms)	0.0	0.5	0.9	1.4	1.8	2.2	2.7	3.0	3.4	3.8
	DISTANCE (cm)	0.0	15.9	31.6	47.1	62.2	76.9	91.0	104.4	117.0	128.7

8.3.3 Coverage result

Below figure shows coverage control over distance with a “steering” delay sequence corresponding to a 15° tilt down.

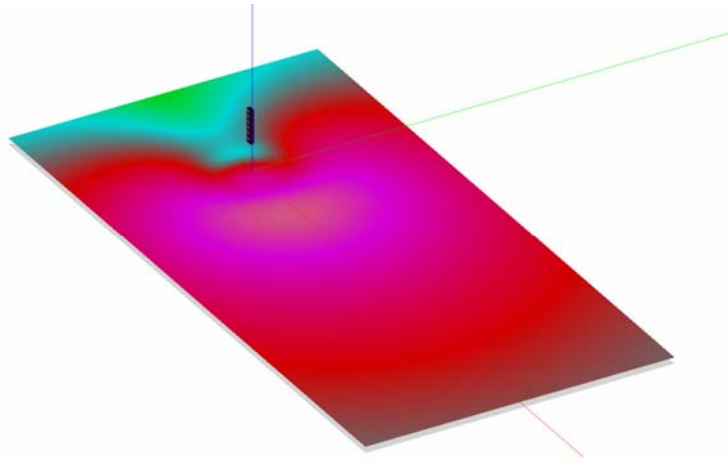

12 RS15 “ALTERNATE” CLUSTER OVER 75M/200FT, STEERED 15° DOWN

8.4 Aligning RS15s with main system

8.4.1 NEXO systems acoustic reference point

The NX TDControllers factory presets are optimised to provide the best possible crossover between the RS15's and PS8/PS10/PS15, GeoS8/Geo12 systems. These crossover algorithms are defined for speaker acoustic reference points being aligned.

The acoustic reference point on all NEXO products is the front of each cabinet, therefore:

- RS15's reference point in Omni Mode is center of the front grid
- RS15's reference point in Directional Mode is center of the face opposite to connector panel.

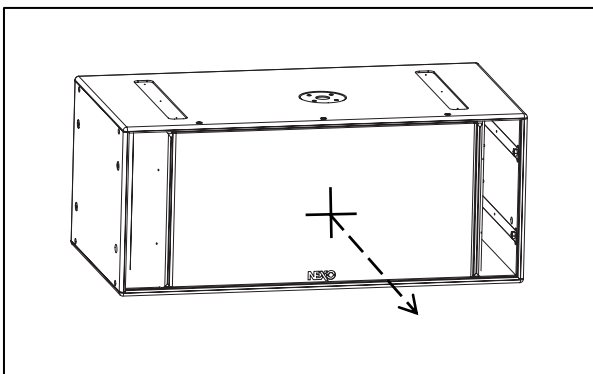

RS15 REFERENCE POINT IN OMNI MODE

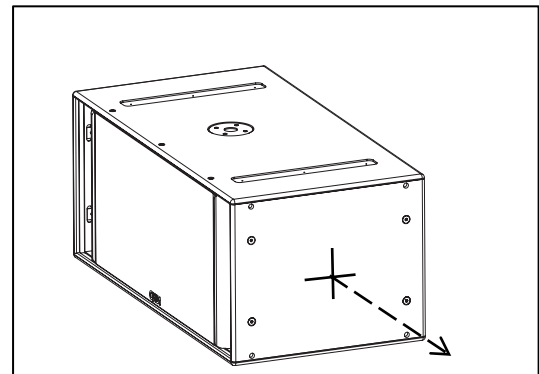

RS15 REFERENCE POINT IN DIRECTIONAL MODE

8.4.2 Precautions

It is common to use the AUX send of a mixing desk to drive the Sub section of a PA system. This gives the mixing engineer more flexibility to set the level of the subbass relative to the main PA, apply special effects, or to use a different EQ on the Sub. However, it also raises some serious issues for the performance & safety of the system (mostly time alignment).

At NEXO, great care is taken to design optimum phase alignment from one octave above to one octave below the crossover frequency point. By doing so, drivers are working perfectly together and providing the best efficiency possible. It is then up to the user to adjust the delay on the NX TDControllers to match the physical path difference of the different systems. It is thus possible to get a well adjusted system, even without measuring instruments.

If RS15s are driven from an AUX output, NX TDController is fed with two signals coming from different sources. If those two sources (MAIN output & AUX send) are not exactly in phase, delay is introduced into the crossover between GEO S12 array and RS15s. It is then mandatory to use proper measurement tool to optimize phase response.

IMPORTANT

- Before using different outputs of a mixing desk, ensure that MAIN and SUB outputs are in phase;
- Never add additional low pass filtering on the SUB output or high pass filtering on the MAIN output;
- Always apply identical processing (EQ etc...) on both outputs, so that the phase relationship between MAIN and SUB is not altered;

8.4.3 Alignment with distance measurement

The fastest way to align RS15 arrays to a main system is simply to measure distance difference from listening point to RS15 and main system reference points.

r_1 being the distance from GEO S12 array to listener position, and r_2 being the distance from RS15 to listener position, the distance difference is then $r_1 - r_2$ (specified meters or feet).

- $r_1 > r_2$, the delay should be set on the RS15 TDcontroller channel.
- $r_1 < r_2$, the delay should be set on the GEO S12 TDcontroller channel
- $\Delta t = (r_1 - r_2)/C$ gives conversion from distance to delay r_1, r_2 in meters, $C = 343$ m/s.

NEXO recommends that main system and subwoofer systems are adjusted so that arrivals from RS15 and PS/GEOS are coincident at a fairly distant listening position (mixing position or further).

Because of proper acoustic reference point definition in NEXO TDControllers DSP setups, this method is highly reliable.

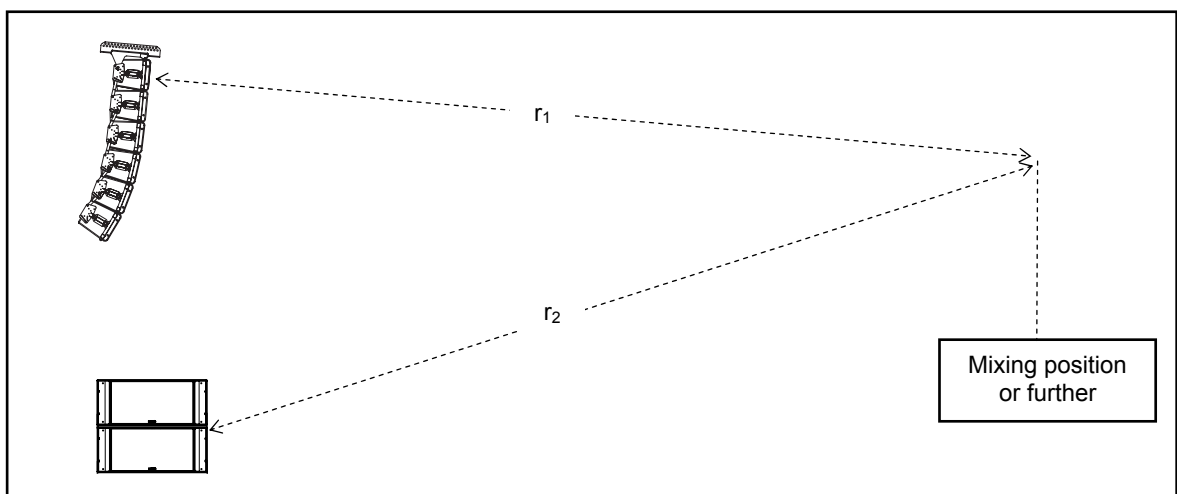

8.4.4 Alignment with phase measurement

Phase measurement with real time FFT analyzer can also provide reliable measurements, provided:

- measurement microphone is set on the ground to avoid floor interference in the reading;
- floor is perfectly rigid (concrete);
- measurement microphone is set far from any walls / ceiling, or inside angles / corners;
- coherence values are high (typically above 75%).

If one of above conditions is not respected, then distance measurement should be preferred.

8.5 Recommended installation tools and equipment

- Tape measure – should be 30m/100ft in length and be of durable fibre material. Have one per array available to speed up the installation process.
- Laser Inclinator – For measuring vertical and horizontal angles in the venue. An ideal product is the Calpac 'Laser projecting a dot' version which costs approximately 60 €.
- Spirit level – used to ascertain the trueness of the surface from which the angle measurements originate.
- Rangefinder measuring device – either a Disto type laser measure or an optical laser rangefinder can be used. Devices such as the Bushnell 'Yardage Pro' sports rangefinders provide sufficiently accuracy and are easy to use. They have the additional advantage of working very well in bright sunlight.
- Electronic calculator with trigonometric functions to calculate the height from ground level to points in the room. The formula to calculate height of a point from measured angle and distance is:
 - Height of point = $\text{Sin}(\text{vertical angle in degrees}) \times \text{distance to point}$
 - NB: Take care when using spreadsheets as they calculate using radians by default. To convert degrees to radians use the formula:
 - Angle (in radians) = $3.142 \times \text{Angle (in degrees)} / 180$
- Computer – Laptop or Desktop PC running Windows 2000 or XP with the current version of NEXO GeoSoft2 installed. It is not possible to configure a Geo tangent array properly without using GeoSoft2. Note that, when GeoSoft2 designs are prepared prior to arrival at the venue, it is often necessary to modify or update the design to accommodate special circumstances. A PC is absolutely essential to make such changes.
- Audio Analysis Software – recommended but not absolutely essential, programs such as Easera Systune™, Spectralab™ or WinMLS™ enable rapid and detailed analysis of the installation. Consider taking a training course in using one of these tools if you are not already competent with them – it will pay dividends in increased performance of the system.

9 RS15 SYSTEM CHECK LIST

It is essential to execute all these check steps prior to a sound check on the “front end” to the system. Following this checklist step by step will prevent many troubles and will save time in the end.

9.1 Are the NX Digital TDcontrollers properly configured?

IMPORTANT

If you must change any of the parameters listed below, make sure that you use the same values on all NX's.

9.1.1 NX settings

Output Assignment

NX Setup / NXChannel	1	2	3	4
RS15 4 Channels Omni Mode	RS15-1	RS15-2	RS15-3	RS15-4
RS15 Stereo Directional Mode	RS15 Rear Left	RS15 Front Left	RS15 Rear Right	RS15 Front Right

Output parameters

Output Label	Amp Gain (2)	Amp Power (2)	Global Gain	Global Delay	Sense Gain	Array EQ (3)	Headrom (4)
All channels	26 dB	refer to amp	0 dB	0 ms	0 dB	0	5 bars

- (1) Local gain and delay values are inter-locked on channel 1&2 and 3&4 in Directional Mode
- (2) values for recommended amplifier gain and power : should be set in agreement with selected amplifiers specifications
- (3) Should be in agreement with implemented cluster; acts on a shelving filter designed to compensate for LF coupling.
- (4) Disabled when using digital inputs.

9.2 Are the amplifiers properly configured?

Freq. Band	Mode	Gain Switch	Limiter	High Pass
All channels	Stereo	26 dB	None	None

9.3 Are the amps and the NX properly connected?

Check that the sense lines on the NX's are properly connected by applying a signal to the corresponding output and verify that the correct Sense LED illuminates.

9.4 Are the speakers properly connected?

- Attach the first serie of modules to the bumper
- Before flying, verify that all drivers of all modules are functioning properly.
- Make sure that each RS15 driver is producing proper summation in omni mode:
 - The two RS15 individual 15” driver should sum up by 6 dB;
 - Doubling RS15 quantity (2, 4 and so on) should also produce 6 dB gain.
- Make sure that each RS15 is producing the proper front/rear summation in directional mode:

- when listening from behind the system, switch the front drivers in and out. You should hear a reduction in the LF range when the both front and rear drivers are on as compared to when the rear drivers only are on;
- When listening from the front, you should hear a strong increase in the LF range when connecting the rear drivers.
- Raise the bumper, attach the next series of modules and repeat the above checks.
- Make sure that these series of modules sum properly with the modules above them.

9.5 Final Pre-Sound Check Check

- Play a CD track (preferably generous and periodic in the LF content) on the SUB output, mono left, mono right and then both sides:
 - both sides must sound strictly identical when listening at the center;
 - level must not decrease at the center when playing left and right simultaneously as opposed to one side only.
- Play the same CD track on the MAIN system, on the SUB system, then on both:
 - Inverting polarity on one of these outputs – MAIN or SUB - should always result in a massive difference near the crossover point.

10 RS15 TECHNICAL SPECIFICATIONS

10.1 System specifications

RS15 PRODUCT FEATURES	
Components	2 x 15" (38cm) long excursion neodymium 8Ω drivers
Height x Width x Depth	454 x 564 x 1074mm (17.9" x 22.2" x 42.3") without accessories
Shape	Rectangular
Weight	Net Weight without accessories 52Kg (115 lbs)
Connectors	2 x NL4MP SPEAKON 4 pole (In & Through)
Construction	Baltic Birch ply finish with structured black coating Dark grey carpet finish also available

RS15 with NX242-ES4 TDcontroller or NXAMP SYSTEM SPECIFICATION		
	Omni	Directional
Frequency Response @ -3db [a]	35Hz–100Hz	35Hz-100Hz
Usable Range @ -6db [a]	35Hz–250Hz	35Hz–150Hz
Sensitivity 1W @ 1m [b]	105dB SPL Nominal	103dB SPL Nominal
Peak SPL @ 1m [b]	136–139dBPeak (2x700W to 2 x 1200W/8Ω)	133–136dBPeak (2x700W to 2 x 1200W/8Ω)
Dispersion	Omni & Directional pattern over the entire useable bandwidth depending on the NX242 or NXAMP TDcontrollers setup. (two channels of the NX242ES4 or NXAMP are required to process directional setups)	
Directivity Index [c]	1.5<Q<2 1.7dB<DI<3dB	Q=4.3 DI=5.3dB
Crossover Frequency: NX242 or NXAMP TDcontrollers preset dependent	From 80Hz to 200Hz	From 80Hz to 125Hz
Nominal Impedance	2 x 8Ω	2 x 8Ω
Recommended Amplifiers	1 amplifier channel is required for omni mode operation, rated at 1400 to 2400 Watts into 4Ω!	2 amplifier channels are required for directional mode operation, each rated at 700 to 1200 Watts into 8Ω per channel

SYSTEM OPERATION	
Electronic Controller	GEOS12 Analogue TDcontroller, NX242ES4 Digital TDcontroller & NXAMP Powered Digital TDcontroller presets are precisely matched to RS15 and include sophisticated protection systems. Using RS15 without a properly connected TDController will result in poor sound quality and can damage components.
Speaker Cables	1-/1+ = Right or Rear 2-/2+ = Left or Front The RS15 must use separate cables to the main system
Accessories	Bumper – Flying Plates – Handles - Dolly-Rear Wheel Board
Rigging system [d]	Please refer to the user manual before any operation

SHIPPING & ORDERING	
Packaging	RS15s are packaged individually. Order RS15-C (finished grey carpeting) or RS15-P (finished in black structured coating)

As part of a policy of continual improvement, NEXO reserves the right to change specifications without notice.

[a] Response curves and data: anechoic far field above 200 Hz, half-space anechoic below 200 Hz.

[b] Sensitivity & peak SPL: will depend on spectral distribution. Measured with band limited pink noise.

Refers to the specified +/- 3 dB range. Data are for speaker + processor + recommended amplifier combinations.

[c] Directivity curves and data: 1/3 octave smoothed frequency response, normalized to on-axis response. Data obtained by computer processing of off-axis response curves.

[d] Please refer to the RS15 user Manual.

Usable range data: frequency response capability with TD crossover slopes removed.

10.2 Dimensions

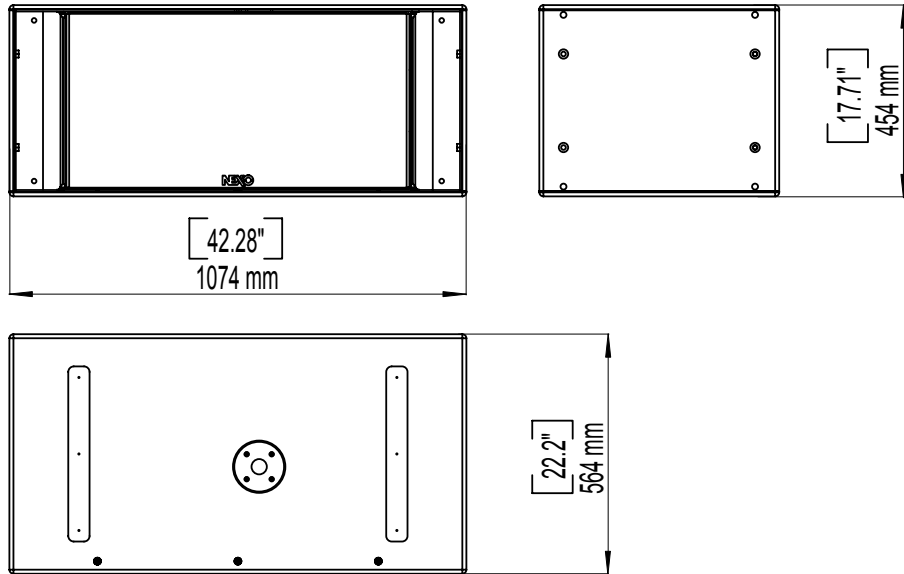

10.3 Diagrams

10.3.1 Frequency Response and Impedance

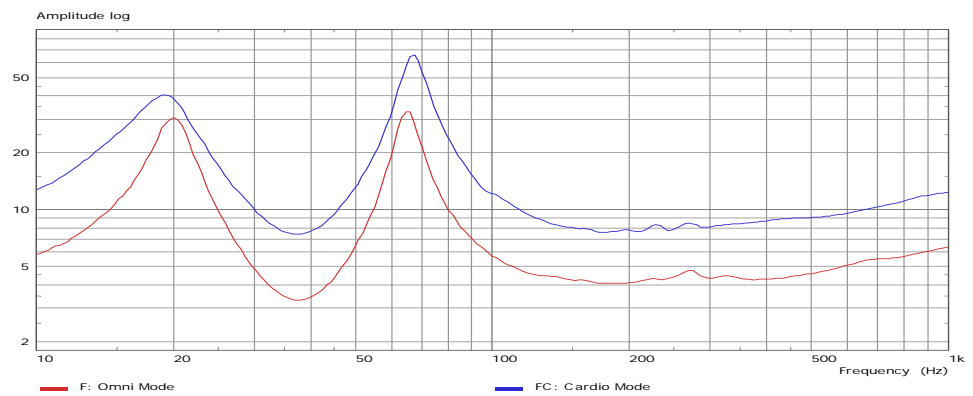
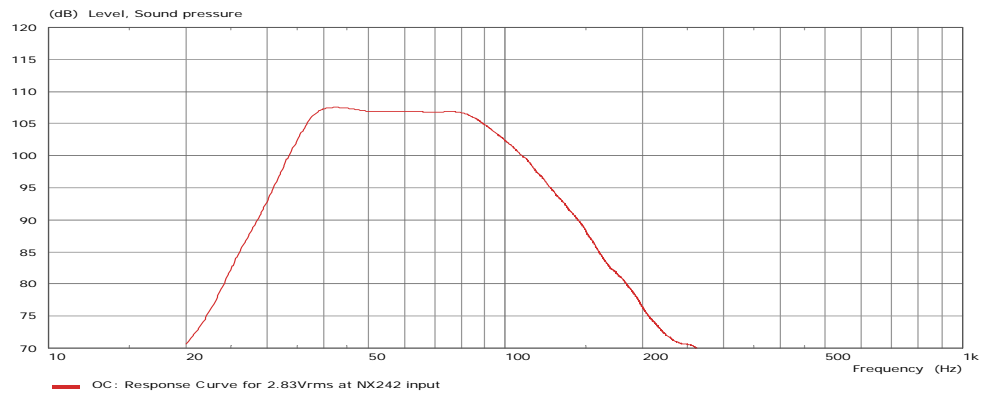

10.3.2 Polar plots

Omni Mode (2xRS15 front)

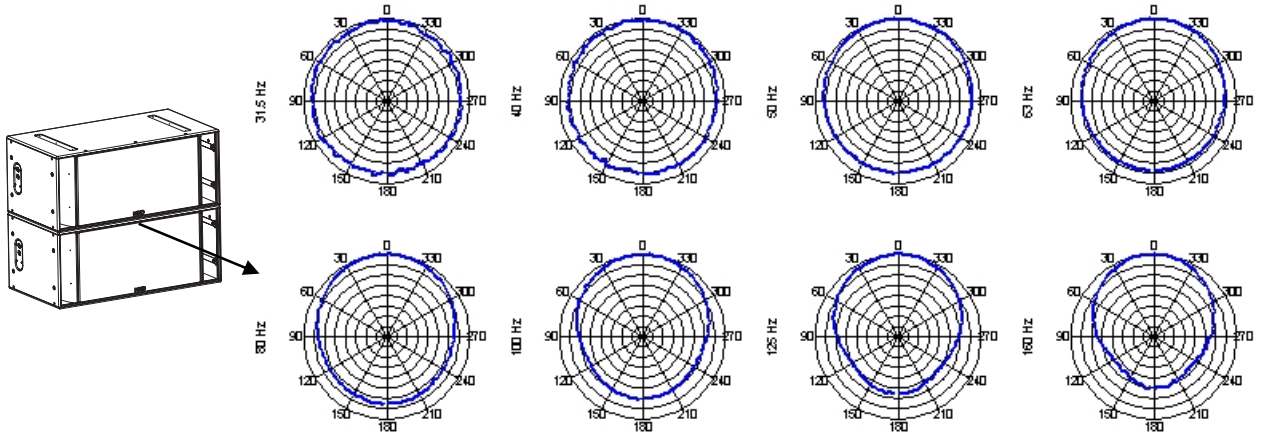

Directional Mode (2xRS15 side)

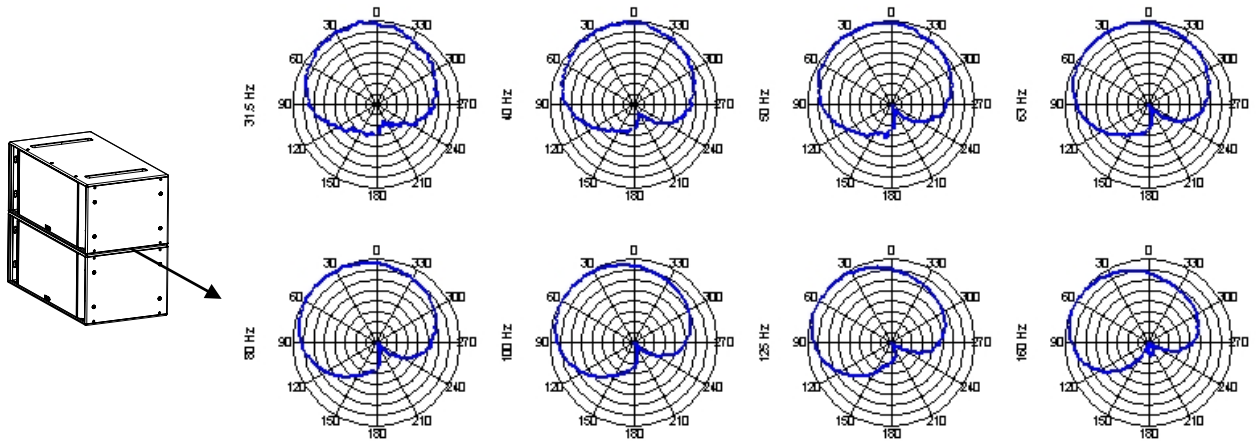

Directional Mode (2xRS15 alternate)

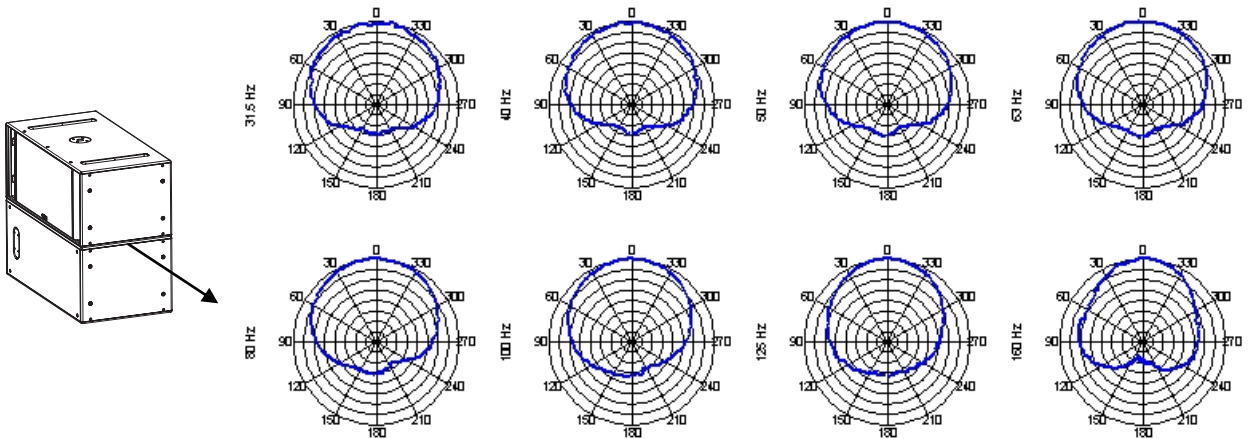

Directional Mode (2xRS15 face to face - 50cm - 20")

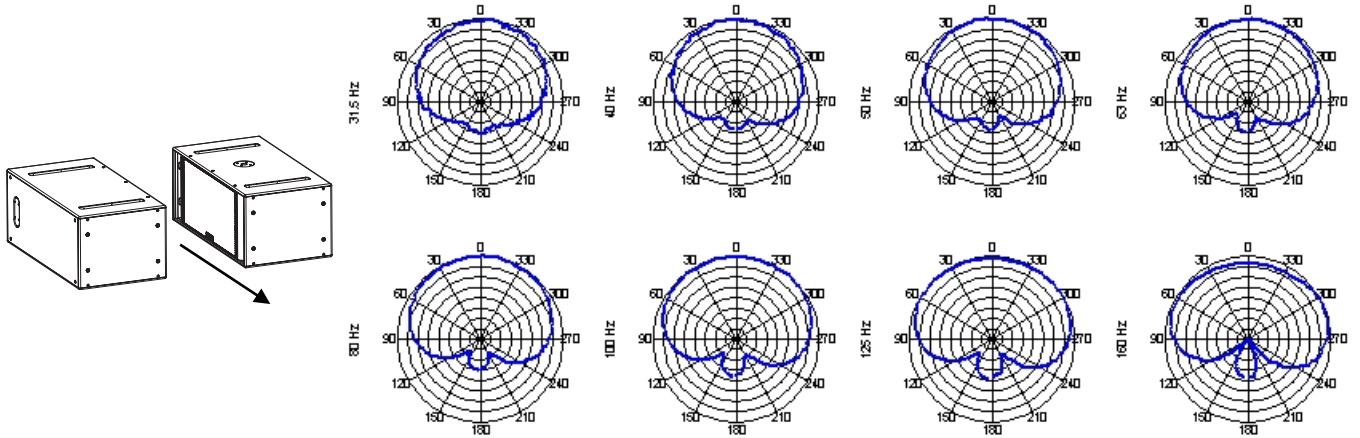

Directional Mode (2xRS15 back to back)

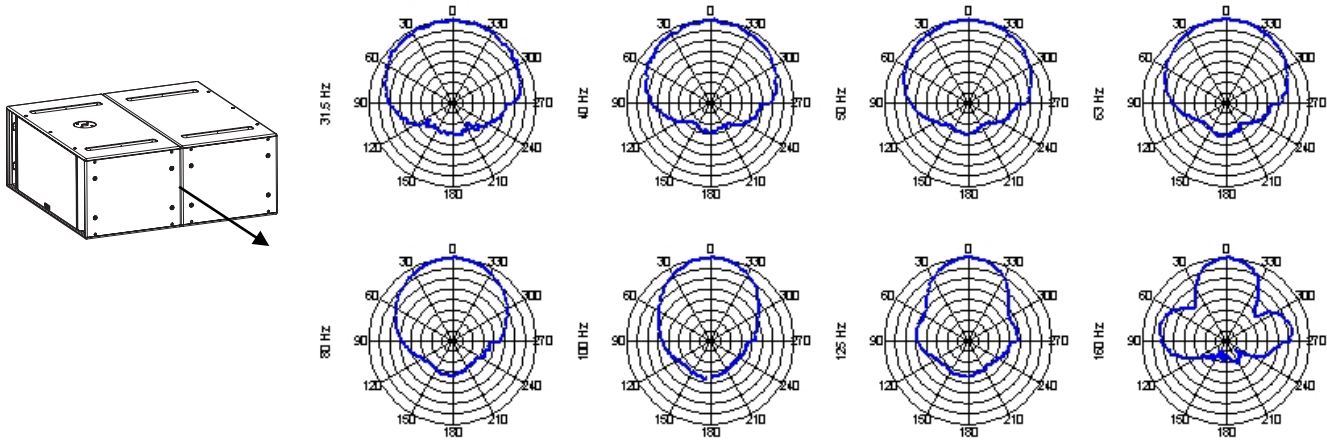

10.4 RS15 Accessories

10.4.1 RS15-BUMPER

Dimensions

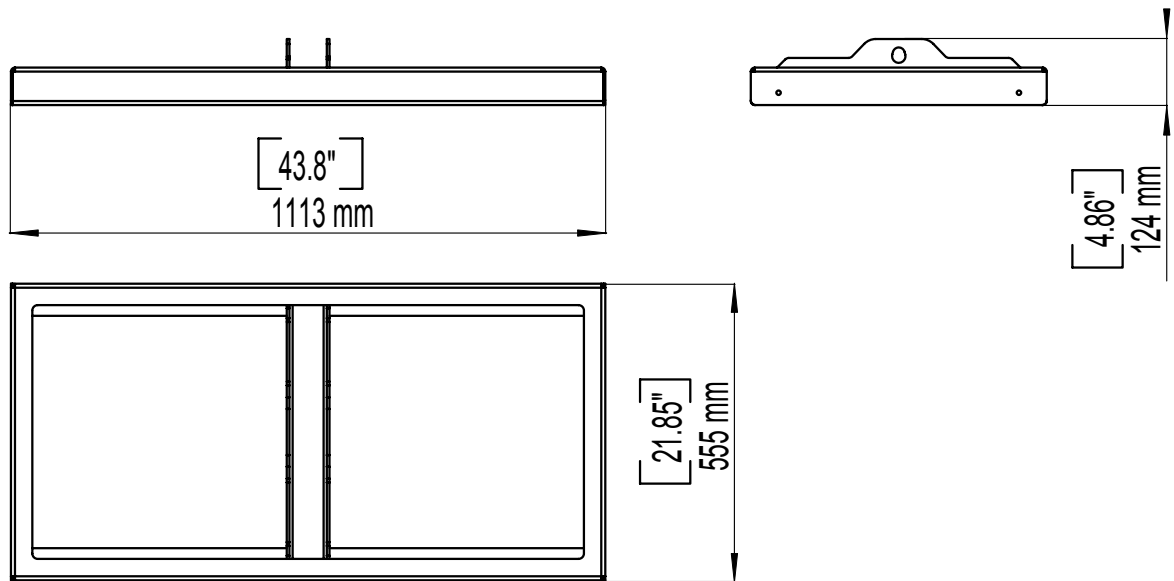

10.4.2 RS15-FPLATES

Dimensions

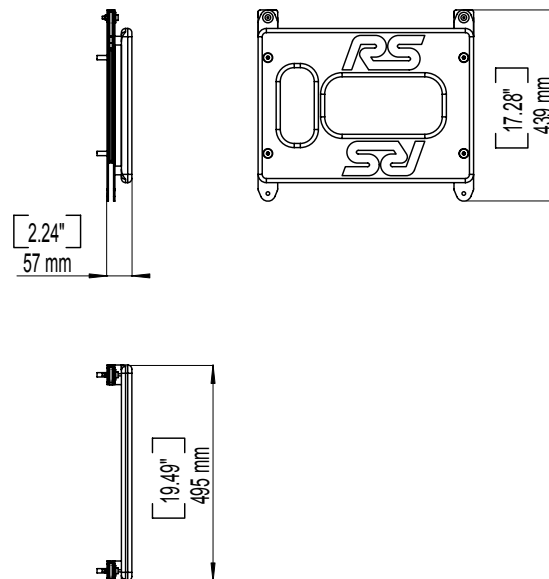

10.4.3 RS-15 HANDLES

Dimensions

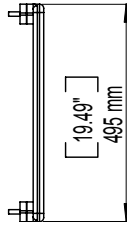
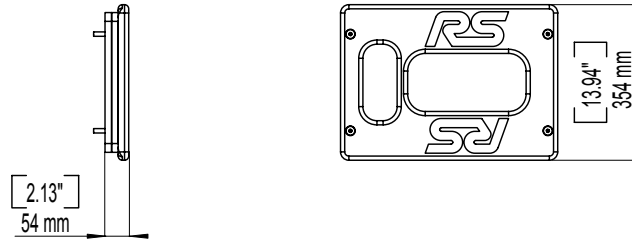

10.4.4 RS15-WHEELS

Dimensions

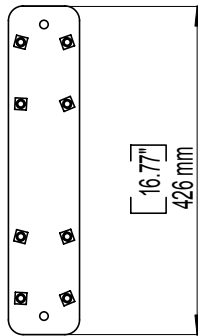
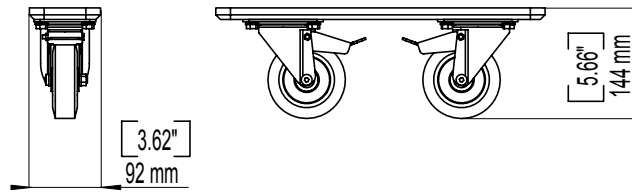

10.4.5 RS15-DOLLY

Dimensions

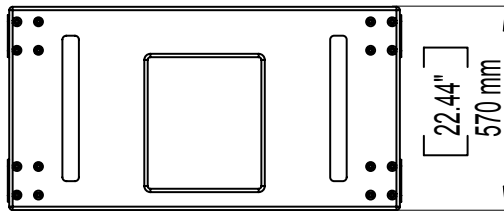
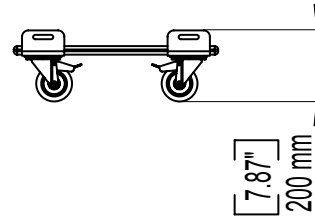
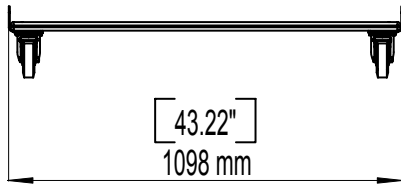

10.4.6 RS15 Push-Pins (BLGEOS)

Dimensions

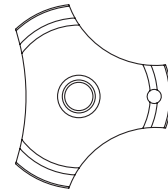
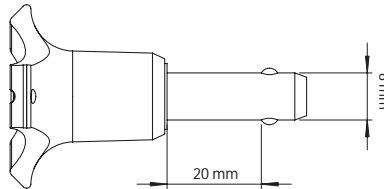
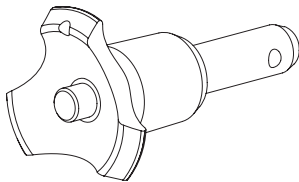

10.5 GEO S12 Analogue TDController

10.5.1 Specifications

SPECIFICATIONS	
Output Section	+22 /+16/+10 dBm typ. into 600 Ohm load. Back Panel switch on +6/0/-6dB respectively.
Input Section	Maximum input Level : 22dBu. CMRR 80dB @ 1kHz typ.
THD+N	0.1% @ 1kHz Typ. for +10dBm Output
Noisefloor	S12TD -100 dBV for 0dB switch position (22 Hz - 22 kHz, Unweighted)
Dynamic Range	111 dB Unweighted (THD+N at-60dB sine wave @1kHz rel.max. output)
Crosstalk	104dB
Filtering & EQ.	L&R: 12dB/oct Low Pass, 12dB/oct High pass (crossover or overlap), 4 Parameter EQs. All factory defined
Protections	VCA temp. (SUB,LF & LF), VCEQ disp. (SUB & LF), Peak Limiter (all chanel), Power compression regulation
Power Supply	100-250 Volts (continuous operation), 50/60Hz. Power 9W. Peak Inrush current 0.5A. Earth-Lift.
Conformity	Comply with safety objective of 73/23/EEC & 89/336/EEC directives. (EN60065-12/2001, EN55103-1996). CB scheme DK-8371, cULus 60065 AZSQ E241312, FCC part15 class B
PRODUCT FEATURES	
Audio Inputs	Two differential non floating L&R Audio inputs, 50 kOhm. Two XLR-3F connectors.
Sense Inputs	Three Amplifier Sense Inputs (S12 L&R, LS). 400 kOhm. 6 Pole Removable Strip Terminal
Audio Outputs	Two L&R S12 Audio outputs. Balanced, non floating, 51 Ohm. Two XLR-3M. One Mono (L+R) LS400 Audio output. Balanced, non floating, 51 Ohm. One XLR-3M.
Controls	Gain switch (back panel), 3 positions : -6 / 0 /+6dB. Peak Limiter trimmer (1200W-600W/8 Ohms) for S12 & Subbass Sub Overlap / Crossover switch & Sub Gain Control (-/+ 6dB).
Indicators	LF speakers Protect Yellow LED's (Temp. & Disp), Power ON (green), Amp Sense & Peak LED's (green/Red)
Dimensions	1U 19" Rack. 165mm (6.5") Depth
Weight :	2.9 kg (6.6 lbs) net
SYSTEM OPERATION	
Applicable Products	The S12 TDcontroller is precisely matched to the S12 & associated Subbass and includes sophisticated protection systems. Use of either product without a properly connected Controller will result in poor sound quality and may damage the components.
SubBass	Active two-way operation of the S12 Loudspeaker with the associated Subwoofer is included in the Analogue S12 TDcontroller .

10.5.2 Front and Rear Panel view

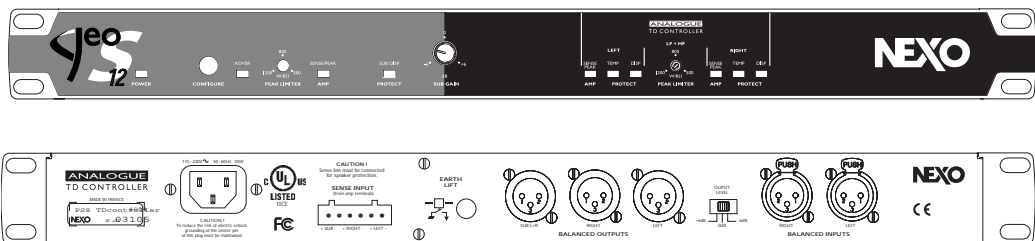

10.6 NX242 Digital TDController with NX-Tension Card

10.6.1 Specifications

SPECIFICATIONS	
Output Level	+28 dBu Max. into 600 Ohm load
Dynamic Range	110 dBu
THD + Noise	< 0.002% flat setup (for output at 27.5dBu)
Latency time	1.7ms on a flat setup
Power Supply	90V-260V
PRODUCT FEATURES	
Audio Inputs	2 Audio Inputs 24 bit converters Electronically Balanced, 50k Ohm. 2 XLR-3F Connectors. 4 Digital Ethersound Inputs with NXTension ES4 Card
Sense Inputs	4 Amplifier Sense Inputs Floating 150 kΩ. 18 bit converters 8 Pole Removable Strip Terminal.
Audio Outputs	4 Audio Outputs. 24 bit converters Electronically balanced, 50 Ohm 4 XLR-3M connectors 4 Digital Ethersound Outputs with NX-ES4 Card (enabled for compatible amplifiers only)
Processing	24 bit data with 48-bit accumulator. 200 MIPS
Front Panel	Menu A and Menu B buttons 16 characters by 2 lines display Select Wheel & Enter button (◀▶) IN Clip – DSP Clip red LED's Speaker Protection yellow LED for each channel Individual Mute/Solo buttons and red LED for each channel Amp. Sense & Peak (green & red) LED's for each channel
FLASH EPROM	Software updates/upgrades, new system setups, available on www.nexo-sa.com
Rear Panel	RS232 connector for serial com 2 x RJ45 connectors with NXTension ES4 Card 1 RJ45 + 2 RJ11 with NXTension CAI Card
Dimensions & Weight	1U 19" Rack - 230 mm (9") Depth. 4 kg

10.6.2 Front and Rear Panel view

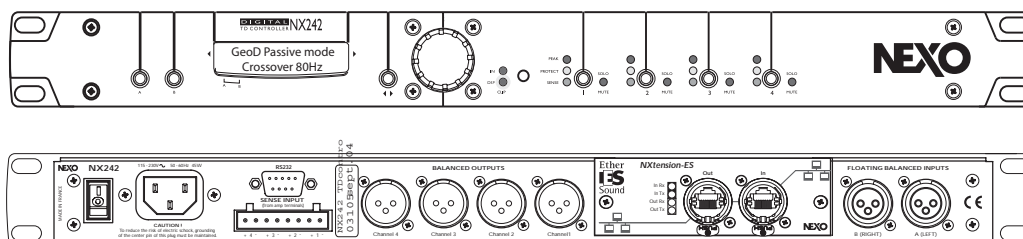

10.7 NXAMP4x1 & NXAMP4x4 Powered Digital TDControllers

10.7.1 Specifications

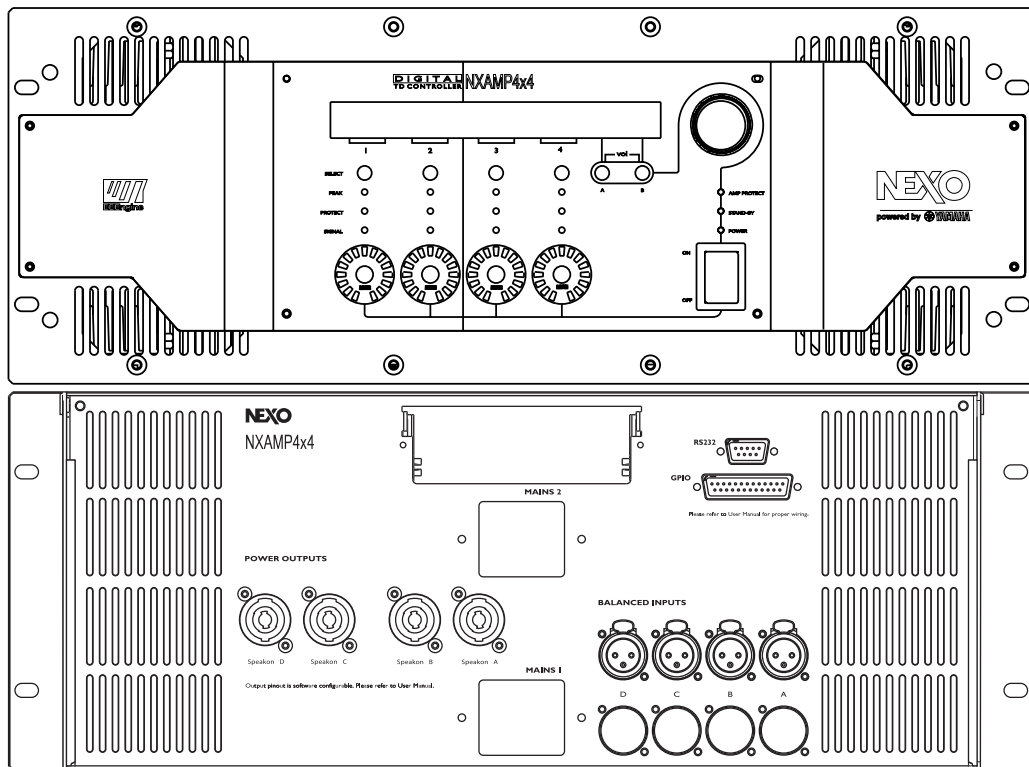

SPECIFICATIONS	NXAMP4x1	NXAMP4x4
Number of Amplifier Channels	4 channels, 2 by 2 bridgeable	4 channels, 2 by 2 bridgeable
Max Output Voltage (no load)	4 x 105 V	4 x 200 V
Max Output Power (8Ω)	4 x 600 W	4 x 1900 W
Max Output Power (4Ω)	4 x 900 W	4 x 3300 W
Max Output Power (2Ω)	4 x 1300 W	4 x 4000 W
Power Consumption (Standby)	10 W	20 W
Power Consumption (Idle)	100 W	150 W
Power Consumption (1/8 Power)	1100 W	3000 W
Analog Input Channels	4 channels In / Out	
Frequency Response	+/-0.5dB from 10 Hz to 20 kHz	
Input Impedance	20 kΩ	
Max Input Level	+28 dBu	
Dynamic Range	105 dB unweighted	
THD+Noise	Typical 0.1% flat setup	
Latency Time	500us on flat setup	
FEATURES		
Audio Inputs Connectors	4 balanced analogue inputs on XLR3F + links on XLR 4 digital inputs via optional Ethersound Card	
Speaker Outputs Connectors	4 Speakon outputs with internal power relays for automatic output assignment.	
RS232 Port	Allows firmware upgrade for software improvement and new speakers setups	
GPIO Port	5 Global Purpose Inputs and 8 Global Purpose Outputs, software assigned	
DSP Processing	Two DSP's 24bits 48bit accumulator 700MIPS	
Front Panel	On/off Mains switch, Select Wheel, Menu A and Menu B buttons, 40x2 characters display, amp protect, stand-by and power LED's, volume indicators (15 LED's), Mute buttons and red LED, output current signal green LED, Speaker protection yellow LED, amp peak red LED	
Rear Panel	1 (NXAMP4x1) or 2 (NXAMP4x4) mains sockets, RS232 serial communication connector, GPIO port, expansion slot for digital audio network extension card, 4 XLR inputs, 4 XLR links, 4 Speakon NL4.	
Power Supply	Dedicated versions for 100-120 V or 220-240 V	
Dimensions & Weight	NXAMP4x1: 3U 19" Rack – 457mm (18") Depth – 16.5kg (33lbs) net NXAMP4x4: 4U 19" Rack – 457mm (18") Depth – 24.5kg (49lbs) net	
NXAMP USER CONTROLS		
System Selection	Allows control across all NEXO range	
System Setup	Within selected range, allows cabinets to be set for: passive or active; wideband or cross-over; cross-over points; omni or directional modes.	
Protections (factory defined)	Peak limiters fitted for both selected speaker and amplifier; Acceleration protection preventing membrane stress Displacement protection preventing over-excursion Temperature protection preventing voice-coil damage Inter-channel regulation	
Delay	Up to 150m (330ft) in 10cm (4") steps	
Input Patching	Allows any of the inputs to be routed to any output	
Output Gain	Global and individual channel gain +/-6dB in 0.5dB steps	
Volume Control	Global and individual channel gain -inf to 0dB in 16 variable steps	
Save / Recall	Stores up to 40 user setups; "On-the-Fly" recalls	
Array EQ	LF or HF shelving filters to compensate for arrays quantity dependent behaviour	
Security Mode	Password protected for Read-Only or Remote-Only modes	
Remote Control	Full Remote Control via Ethersound Digital Network Protocole and ESMonitor software	
STATUS		
Green Status	ROHS, WEEE	
Certification	UL, SEMKO (CE), CCC, KOREA, TSS, PSE	

10.7.2 Front and Rear Panel view



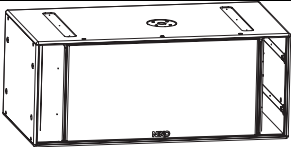

11 RS15 PARTS & ACCESSORIES LIST

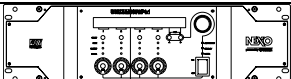
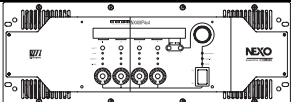
11.1 Modules & Control Electronics List

MODEL	DRAWING	DESCRIPTION
RS15		RS15 Subwoofer
GEOS12TD		Analogue GEOS12 TDController
NX242ES4		Digital TDController with NXtension Card
NXAMP4x1		Power Digital TDController 4x1300W/2Ω
NXAMP4x4		Power Digital TDController 4x4000W/2Ω

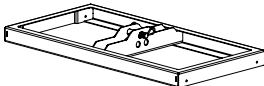
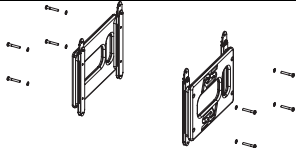
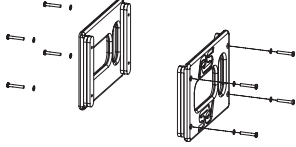
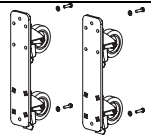
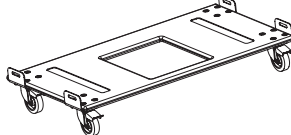
11.2 Accessories List

MODEL	DRAWING	DESCRIPTION
RS15-BUMPER		Main RS15 Bumper
RS15-FPLATES		Rigging plate with handles (pair).
RS15-HANDLES		Handles (pair)
RS15-WHEELS		2 Wheels on wood skids (pair)
RS15-DOLLY		RS15 Dolly (3 RS15 max)
BLGEOS		Quick Release Pin for Geo S8 / GeoS12 / RS15

12 USER NOTES

France
Nexo S.A.
Parc d'Activité de la Dame Jeanne

F-60128 PLAILLY
Tel: +33 3 44 99 00 70
Fax: +33 3 44 99 00 30
E-mail: info@nexo.fr
www.nexo-sa.com