

## ProFX8 and ProFX12

The Mackie ProFX Series mixers include effects, graphic EQ and USB I/O for playing and recording two channels of audio using a computer all in one compact package.

The ProFX8 is a Professional 8-channel Compact Mixer with four mic preamps and three full stereo channels while the 12-channel ProFX12 comes standard with six mic preamps and four full stereo channels.

Each channel has an input Gain control with 50 dB of gain, a sharp 18 dB/octave, 100 Hz Low Cut filter, a 3-band EQ, two Aux sends [monitors and FX], Pan, Mute and a 60mm fader. All mono channels have a Channel Insert jack for connecting an external processor, as well.

Additionally, the ProFX Series mixers include Mackie's classic high-headroom, low-noise mic preamps, 3-band active EQ (80 Hz, 2.5 kHz and 12 kHz) on all channels, a built-in DI for direct connection of a guitar or bass on channel 1, integrated effects and a precision 7-band graphic EQ for tuning the room or the monitors.

The 32-bit RMFX™ processor has 16 “Gig-Ready” effects, including reverbs, choruses and delays. ProFX allows stereo playback from, and recording to, a computer via USB. The innovative “USB Thru” switch allows for an impressive live/recording setup utilizing performance software.

Other features include phantom power, a stereo tape input and output, a 1/4” stereo headphone jack, stereo 12-segment LED meters, XLR and TRS stereo output jacks and a footswitch jack to connect a remote control for muting the FX.

## APPLICATIONS

Live sound mixing, houses of worship, clubs, gymnasiums, banquet halls, conference rooms, boardrooms, studio and field recording, video post-production, multimedia applications, broadcast, and many, many more.

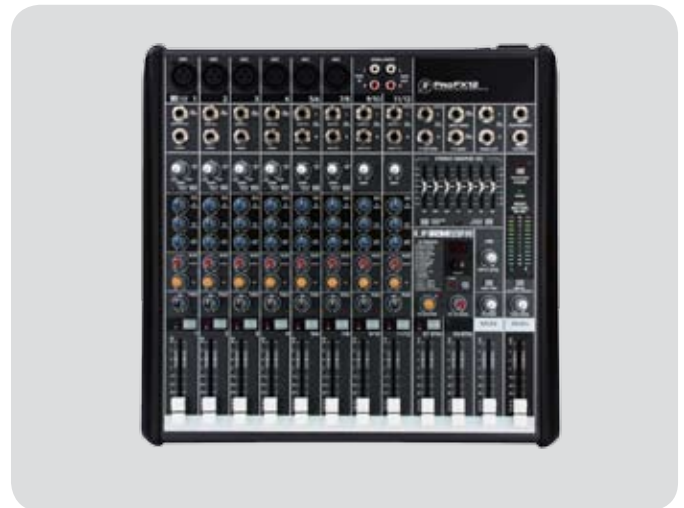

## FEATURES:

- Professional compact mixer with onboard effects and USB I/O
- Low-noise, high-headroom Mackie mic preamps with easy LED metering
- 32-bit RMFX™ processor with 16 “Gig-Ready” effects
- 7-band graphic EQ for tuning Mains or Monitors
- USB I/O for recording shows and music playback via Mac or PC
- Extra stereo channels plus extra stereo return for keyboards, external effects or stereo playback devices
- 60mm faders for input channels, returns and Main/Monitor masters
- 3-band active EQ on all channels
- Hi-Z input for direct connection of guitar, bass and other instruments
- Insert, 100 Hz low cut filter, and 48V phantom power on all mic channels
- Stereo RCA tape I/O with input level control
- Headphone output with separate rotary level control
- Balanced XLR and balanced/unbalanced 1/4” main outputs
- FX mute with remote control via footswitch
- Break switch mutes all channels for music playback
- Built-like-a-tank steel chassis
- Planet Earth switching power supply for worldwide use

## ProFX 8 and ProFX12 SPECIFICATIONS

### Noise Characteristics

(20 Hz to 20 kHz, 150Ω Source Impedance Equivalent Input Noise)	
Mic in to Insert Send out, max gain	-127 dBu
(Residual Output Noise)	
All outputs, master levels off, all channel levels off	-95 dBu
All outputs, master levels unity, all channel levels off	-90 dBu
All outputs, master levels unity, one channel level unity	-85 dBu

### Frequency Response

(Mic input to any output, gain at unity)	
20 Hz to 30 kHz	+0 dB / -1 dB

### Distortion (THD+N)

(20 Hz to 20 kHz bandwidth)	
Mic in to Main out	<0.05% @ +4 dBu output

### Attenuation and Crosstalk

(1 kHz relative to +10 dBu, 20 Hz - 20 kHz bandwidth, Mic In, 1/4" Main Out, Gain @ unity)	
Channel Mute switch engaged	-90 dBu
Channel Fader down	-90 dBu

### Common Mode Rejection Ratio (CMRR)

(Mic In to Insert Send out, unity)	
1 kHz	60 dB gain

### Maximum Levels

All inputs	+22 dBu
Main Mix XLR	+28 dBu
All other outputs	+22 dBu

### Impedances

Mic In	3 kΩ
Channel Insert Return	10 kΩ
Ch 1 Instrument input	1 MΩ
All other inputs	20 kΩ
Tape output	1.1 kΩ
Phones output	25 Ω
All other outputs	120 Ω

### EQ

High Shelving	±15 dB @ 12 kHz
Mid Peaking	±15 dB @ 2.5 kHz
Low Shelving	±15 dB @ 80 Hz
Low Cut Filter	100 Hz, -18 dB/octave

### Maximum Voltage Gain (EQ Flat)

Mic input Channel to	
Insert Output	50 dB
Tape Output	60 dB
USB Output	60 dB
1/4" Main Output	70 dB
XLR Main Output	76 dB
Monitor Send	75 dB
FX Send	90 dB
Mono Line Input Channel to	
Insert Output	30 dB
Tape Output	40 dB
USB Output	40 dB
XLR Main Output	56 dB
Monitor Send	55 dB
FX Send	70 dB
Stereo Line Input Channel to	
Tape Output	30 dB
USB Output	30 dB
XLR Main Output	46 dB
Monitor Send	45 dB
FX Send	60 dB
Tape Input to	
Tape Output	20 dB
USB Output	20 dB
XLR Main Output	36 dB
USB Input to	
Tape Output	20 dB
USB Output	20 dB
XLR Main Output	36 dB
Stereo Return to	
Tape Output	10 dB
USB Output	10 dB
XLR Main Output	26 dB
Effects Return to	
Tape Output	10 dB
USB Output	10 dB
XLR Main Output	26 dB
Monitor Send	25 dB

### Digital Effects

I/O	Mono input / Stereo output
Number of Presets	16 Mackie-designed presets

### Channel Level Set LED

0 dBu (normal operating level)

### Channel OL LED

-1 dB before channel clipping  
measured post-EQ, pre-fader

### Meters

Main L/R Mix  
Two columns of 12 segments each:  
OL (+20 dBu), +15, +10, +6, +3, 0 (0 dBu), -2, -4, -7, -10, -20, -30

## ProFX 8 and ProFX12 SPECIFICATIONS continued...

### 7 Band Graphic EQ

Frequency Centers	125, 250, 500, 1k, 2k, 4k, 8k
Gain	±15 dB
Assignable to Main or Monitor	
Bypassable	

### USB

Format	USB 1.1
I/O	Stereo Input / Stereo Output
A/D/A	16 Bit, 44.1 kHz / 48 kHz

### Phantom Power

48 VDC to all Mic channels at once

### Power Consumption

Voltage Range	100 - 240 VAC, 50 - 60 Hz
Power Consumption	20 watts (ProFX8) 25 watts (ProFX12)
Power Connector	3 Pin IEC

### Physical Properties (packaged product)

Height	7.0 in / 178 mm (both)
Depth	17.5 in / 445 mm (both)
Width	15.5 in / 394 mm (ProFX8) 18.5 in / 470 mm (ProFX12)
Shipping Weight	9.5 lb / 4.3 kg (ProFX8) 11.2 lb / 5.1 kg (ProFX12)

### Physical Properties (product)

Height	14.05 in / 357 mm (both)
Depth	3.58 in / 91 mm (both)
Width	11.41 in / 290 mm (ProFX8) 14.6 in / 370 mm (ProFX12)
Net Weight	7.1 lb / 3.2 kg (ProFX8) 9.0 lb / 4.1 kg (ProFX12)

### Options

Mixer Bag for ProFX8	P/N 0020636
Mixer Bag for ProFX12	P/N 0020637

### Ordering Information

ProFX8 Compact Effects Mixer with USB, US	P/N 0032929-00
ProFX8 Compact Effects Mixer with USB, EU	P/N 0032929-01
ProFX8 Compact Effects Mixer with USB, CN	P/N 0032929-05
ProFX12 Compact Effects Mixer with USB, US	P/N 0032927-00
ProFX12 Compact Effects Mixer with USB, EU	P/N 0032927-01
ProFX12 Compact Effects Mixer with USB, CN	P/N 0032927-05

## ProFX FRONT AND REAR PANELS (ProFX12 shown)

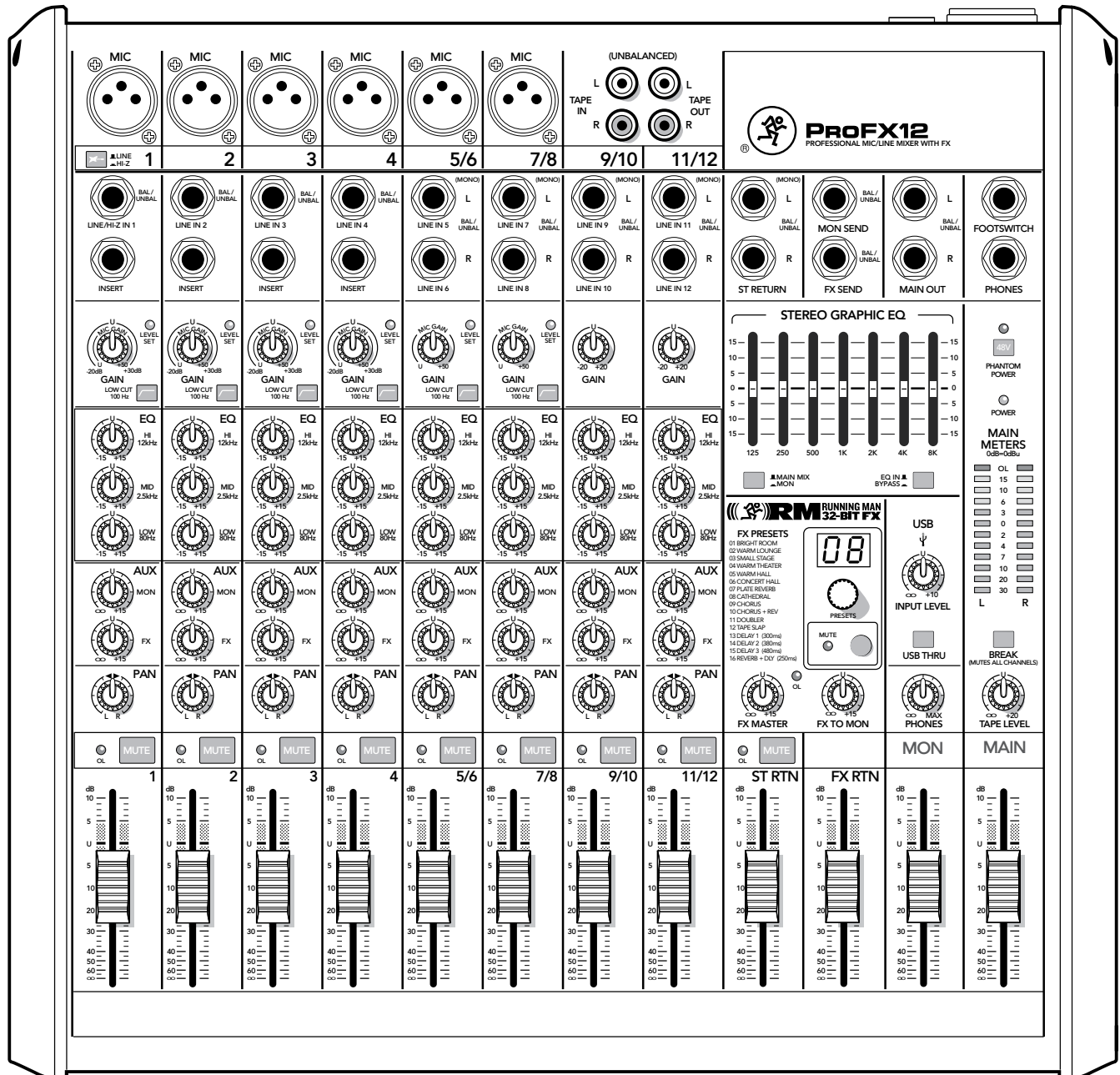
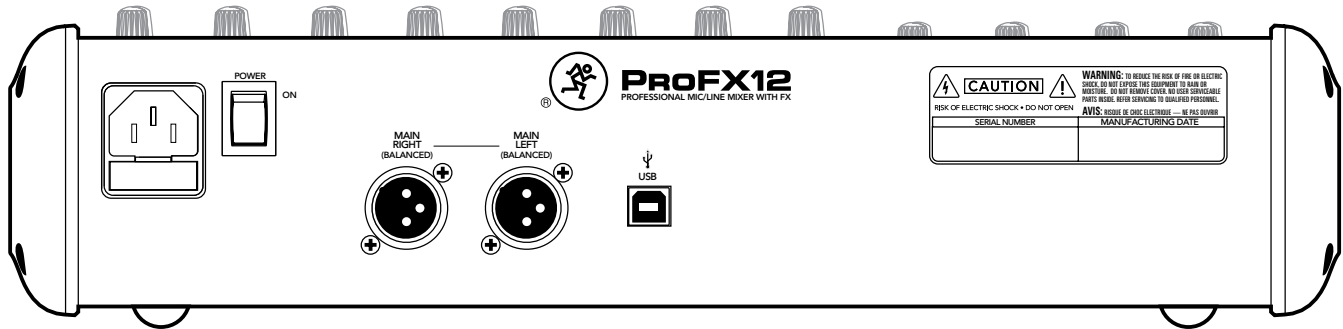

### ProFX 8 and ProFX12 BLOCK DIAGRAM

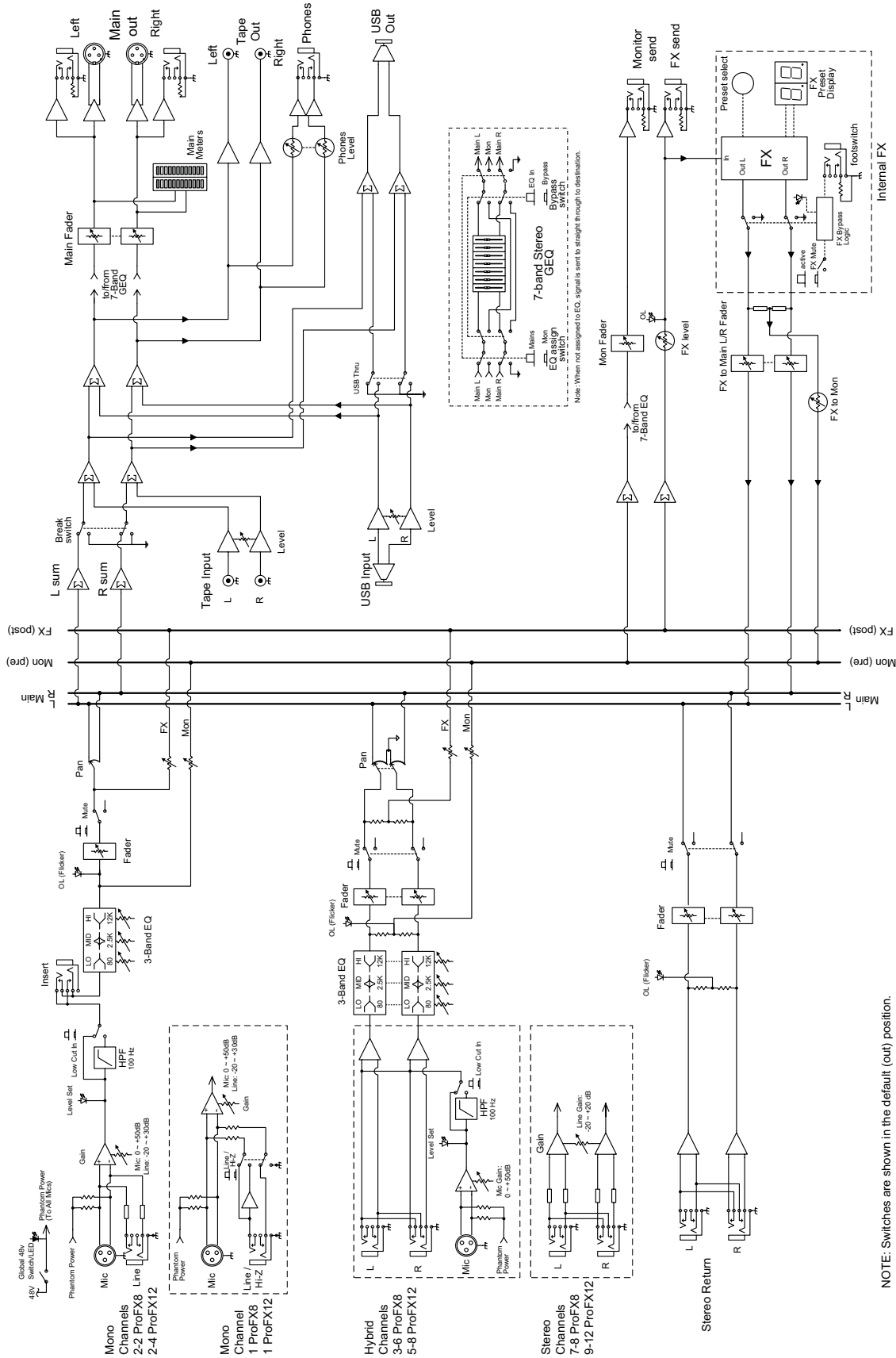

NOTE: Switches are shown in the default (out) position.

### ProFX 8 and ProFX12 DIMENSIONS

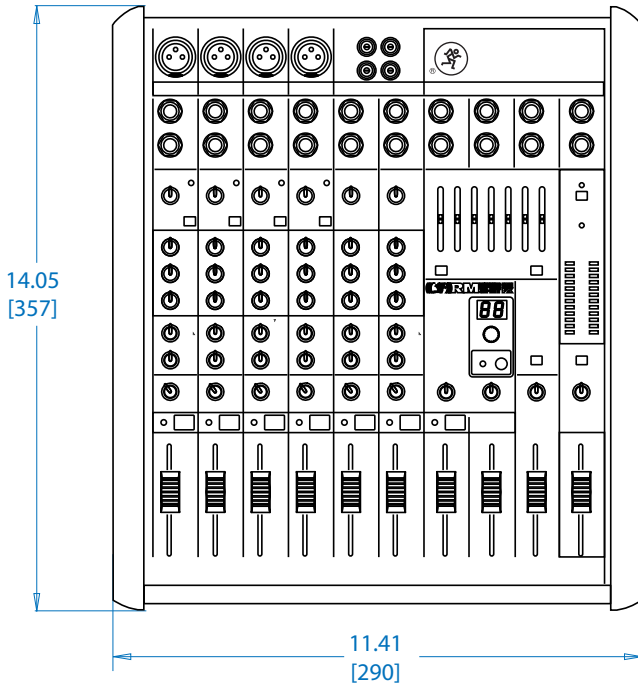

**ProFX8 NOTES:**

1. WEIGHT APPROX. 7.1 lb [3.2 kg].
2. SHIPPING WEIGHT APPROX. 9.5 lb [4.3 kg].

UNLESS OTHERWISE SPECIFIED: ALL DIMENSIONS ARE IN INCHES. DUAL [MM] DIMENSIONS FOR REF ONLY

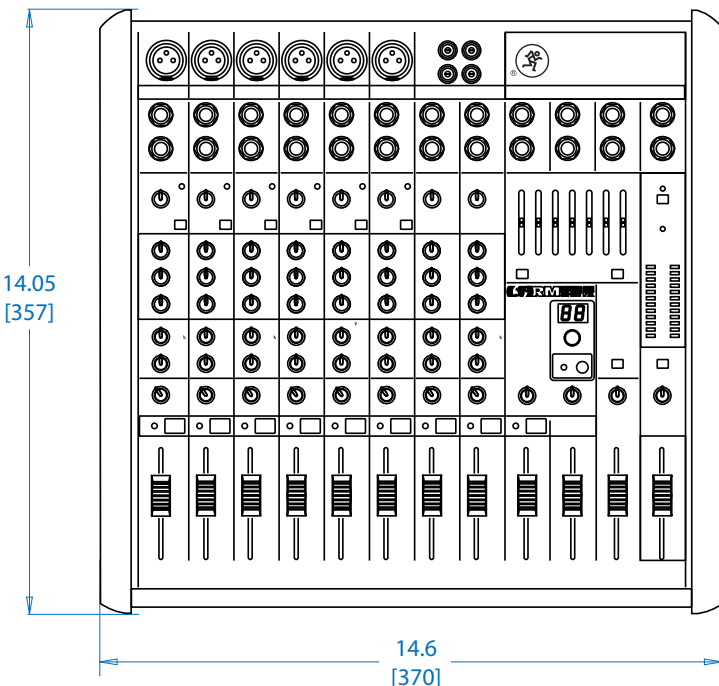
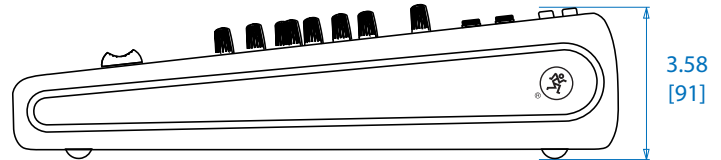

**ProFX12 NOTES:**

1. WEIGHT APPROX. 9.0 lb [4.1 kg].
2. SHIPPING WEIGHT APPROX. 11.2 lb [5.1 kg].

UNLESS OTHERWISE SPECIFIED: ALL DIMENSIONS ARE IN INCHES. DUAL [MM] DIMENSIONS FOR REF ONLY

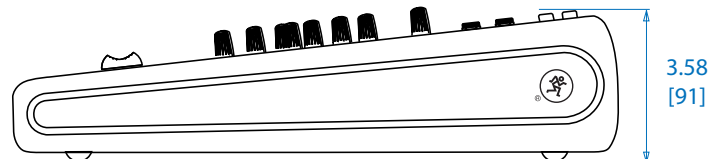

Electronic files for this product are available at:

[www.mackie.com](http://www.mackie.com)

Specification Sheet

PROFX\_SS.PDF

Owner's Manual

PROFX\_OM.PDF

# MACKIE®

www.mackie.com

16220 Wood-Red Road NE

Woodinville, WA 98072 USA

800-898-3211, Fax 425-487-4337, sales@mackie.com

Part No. SW0859 Rev. A 06/10

Since we are always striving to make our products better by incorporating new and improved materials, components, and manufacturing methods, we reserve the right to change these specifications at any time without notice. "Mackie" and the "Running Man" figure are registered trademarks of LOUD Technologies Inc. All other brand names mentioned are trademarks or registered trademarks of their respective holders, and are hereby acknowledged.

©2010 LOUD Technologies Inc. All Rights Reserved.