

marantz
PROFESSIONAL

Model PMD620 User Guide

Handheld Solid State Recorder

	CAUTION RISK OF ELECTRIC SHOCK DO NOT OPEN	
CAUTION: TO REDUCE THE RISK OF ELECTRIC SHOCK, DO NOT REMOVE COVER (OR BACK). NO USER-SERVICEABLE PARTS INSIDE. REFER SERVICING TO QUALIFIED SERVICE PERSONNEL.		



The lightning flash with arrowhead symbol within an equilateral triangle is intended to alert the user to the presence of uninsulated "dangerous voltage" within the product's enclosure that may be of sufficient magnitude to constitute a risk of electric shock to persons.



The exclamation point within an equilateral triangle is intended to alert the user to the presence of important operating and maintenance (servicing) instructions in the literature accompanying the product.

WARNING

**TO REDUCE THE RISK OF FIRE OR ELECTRIC SHOCK,
DO NOT EXPOSE THIS APPLIANCE TO RAIN OR MOISTURE.**

CAUTION:

**USE OF CONTROLS OR ADJUSTMENTS OR PERFORMANCE
OF PROCEDURE OTHER THAN THOSE SPECIFIED HEREIN
MAY RESULT IN HAZARDOUS RADIATION EXPOSURE.**

Copyright

Recording and playback of any material may require consent. For further information refer to the following US ordinances:

- Copyright act of 1956
- Dramatic and Musical Performance Act 1958
- Performers Protection Acts 1963 and 1972
- any subsequent statutory enactments and orders

IMPORTANT SAFETY INSTRUCTIONS

READ BEFORE OPERATING EQUIPMENT

This product was designed and manufactured to meet strict quality and safety standards. There are, however, some installation and operation precautions which you should be particularly aware of.

1. Read these instructions.
2. Keep these instructions.
3. Heed all warnings.
4. Follow all instructions.
5. Do not use this apparatus near water.
6. Clean only with dry cloth.
7. Do not block any ventilation openings. Install in accordance with the manufacturer's instructions.
8. Do not install near any heat sources such as radiators, heat registers, stoves, or other apparatus (including amplifiers) that produce heat.
9. Do not defeat the safety purpose of the polarized or grounding-type plug. A polarized plug has two blades with one wider than the other. A grounding type plug has two blades and a third grounding prong. The wide blade or the third prong are provided for your safety. If the provided plug does not fit into your outlet, consult an electrician for replacement of the obsolete outlet.
10. Protect the power cord from being walked on or pinched particularly at plugs, convenience receptacles, and the point where they exit from the apparatus.



11. Only use attachments/accessories specified by the manufacturer.
12. Use only with the cart, stand, tripod, bracket, or table specified by the manufacturer, or sold with the apparatus. When a cart is used, use caution when moving the cart/apparatus combination to avoid injury from tip-over.
13. Unplug this apparatus during lightning storms or when unused for long periods of time.
14. Refer all servicing to qualified service personnel. Servicing is required when the apparatus has been damaged in any way, such as power-supply cord or plug is damaged, liquid has been spilled or objects have fallen into the apparatus, the apparatus has been exposed to rain or moisture, does not operate normally, or has been dropped.

Additional Safety Information!

- This product should not be placed in a built-in installation such as a bookcase or rack unless proper ventilation is provided or the manufacturer's instructions have been adhered to.
- Apparatus shall not be exposed to dripping or splashing and that no objects filled with liquids, such as vases, shall be placed on the apparatus.
- The AC adaptor shall be installed near the Socket-Outlet and shall be easily accessible.

NOTE:

This equipment has been tested and found to comply with the limits for a Class B digital device, pursuant to Part 15 of the FCC Rules. These limits are designed to provide reasonable protection against harmful interference in a residential installation. This equipment generates, uses and can radiate radio frequency energy and, if not installed and used in accordance with the instructions, may cause harmful interference to radio communications. However, there is no guarantee that interference will not occur in a particular installation. If this equipment does cause harmful interference to radio or television reception, which can be determined by turning the equipment off and on, the user is encouraged to try to correct the interference by one or more of the following measures:

- Reorient or relocate the receiving antenna.
- Increase the separation between the equipment and receiver.
- Connect the equipment into an outlet on a circuit different from that to which the receiver is connected.
- Consult the dealer or an experienced radio/TV technician for help.

NOTE:

Changes or modifications may cause this unit to fail to comply with Part 15 of the FCC Rules and may void the user's authority to operate the equipment.

This Class B digital apparatus complies with Canadian ICES-003.

Cet appareil numérique de la Classe B est conforme à la norme NMB-003 du Canada.

Declaration of Conformity



English

We declare under our sole responsibility that this product, to which this declaration relates, is in conformity with the following standards:
EN55022, EN55024, EN61000-3-2 and EN61000-3-3 Following the provisions of 2004/108/EC Directive.



Français

Nous déclarons, sous notre responsabilité exclusive que ce produit, auquel cette déclaration se rapporte, est conforme aux normes suivantes :
EN55022, EN55024, EN61000-3-2 et EN61000-3-3 suivant les prescriptions de la directive 2004/108/EC.



Español

Declaramos bajo nuestra responsabilidad que el producto al que se refiere esta declaración cumple con las siguientes normas:
EN55022, EN55024, EN61000-3-2 y EN61000-3-3, siguiendo las disposiciones de la Directiva 2004/108/CE.



Deutsch

Wir erklären in alleiniger Verantwortung, dass dieses Produkt, auf das sich diese Erklärung bezieht, mit den folgenden Normen übereinstimmt:
EN55022, EN55024, EN61000-3-2 und EN61000-3-3 Gemäß den Bestimmungen der Richtlinie 2004/108/EG.



Italiano

Il produttore dichiara, sotto la propria esclusiva responsabilità, che il presente prodotto, al quale la dichiarazione fa riferimento, è conforme ai seguenti standard:
EN55022, EN55024, EN61000-3-2 e EN61000-3-3 secondo le disposizioni della Direttiva 2004/108/EC.

Português
Declaramos sob nossa total responsabilidade que este produto, com o qual a presente declaração está relacionada, está em conformidade com as seguintes normas :
EN55022, EN55024, EN61000-3-2 e EN61000-3-3 de acordo com as disposições da Directiva 2004/108/EC.

Svenska
Vi förkunnar under vårt egna ansvar att denna produkt, för vilken detta tillkännagivande gäller, överrensstämmer med följande normer:
EN55022, EN55024, EN61000-3-2 and EN61000-3-3 Enligt villkor i direktiv 2004/108/EC.

Nederlands
Wij verklaren uitsluitend op onze verantwoordelijkheid dat dit product, waarop deze verklaring betrekking heeft, in overeenstemming is met de volgende normen:
EN55022, EN55024, EN61000-3-2 en EN61000-3-3. Volgens de bepalingen van Richtlijn 2004/108/EC.

DMi D&M Installation Europe
Kingsbridge House
Padbury Oaks
Longford
Middlesex
UB7 0EH
UK

English

WARNINGS

Do not handle the AC adaptor with wet hands.

Do not cover the ventilation with any items such as tablecloths, newspapers, curtains, etc.

No naked flame sources, such as lighted candles, should be placed on the equipment.

When disposing of used batteries, please comply with governmental regulations or environmental public instruction's rules that apply in your country or area.

Make a space of about 0.1 meter around the unit.

No objects filled with liquids, such as vases, shall be placed on the apparatus.

When the switch is in the OFF position, the equipment is not completely switched off from MAINS.

To completely disconnect this product from the mains, disconnect the plug from the wall socket outlet.

When setting up this product, make sure that the AC outlet you are using is easily acceptable.

Français

AVERTISSEMENTS

Ne manipulez pas l'adaptateur AC avec les mains mouillées.

Ne pas recouvrir les ouïes de ventilation avec un objet quelconque comme une nappe, un journal, un rideau, etc.

Ne placer aucune source de flamme nue, comme une bougie allumée, sur l'appareil.

Pour mettre au rebut les piles usées, respecter les lois gouvernementales ou les règlements officiels concernant l'environnement qui s'appliquent à votre pays ou région.

Veiller à ce qu'aucun objet ne soit à moins de 0,1 mètre des côtés de l'appareil.

Aucun objet rempli de liquide, un vase par exemple, ne doit être placé sur l'appareil.

Lorsque l'interrupteur est sur la position OFF, l'appareil n'est pas complètement déconnecté du SECTEUR (MAINS).

Pour déconnecter complètement ce produit du courant secteur, débranchez la prise de la prise murale.

Lors de l'installation de ce produit, assurez-vous que la prise CA que vous utilisez est compatible.

ADVERTENCIAS

No manipule el adaptador de CA si tiene las manos mojadas.

No cubra la ventilación con objetos como manteles, periódicos, cor-tinas, etc.

No deben colocarse sobre el equipo elementos con fuego, porejemplo velas encendidas.

Cuando se eliminen baterías usadas, deben cumplirse las regla-mentaciones oficiales o las normas de protección medioambientalaplicables en su país o en su zona.

Deje un espacio de unos 0,1 metro alrededor de la unidad.

No se deben colocar sobre el aparato recipientes que contenganlíquidos, como por ejemplo jarrones.

Cuando el interruptor está en la posición OFF, el equipo no estácompletamente desconectado de la alimentación MAINS.

Para desconectar completamente este producto de la alimentación eléctrica, desconecte el enchufe del enchufe de la pared.

Al ajustar este producto, asegúrese de que la toma de salida de CA que esté utilizando sea fácilmente aceptable.

WARNHINWEISE

Fassen Sie das Netzgerät nicht mit nassen Händen an.

Decken Sie die Lüftungsöffnungen nicht mit einem Tischtuch, einerZeitung, einem Vorhang usw. ab.

Es dürfen keine Gegenstände mit offener Flamme, wie etwabrennende Kerzen, auf dem Gerät aufgestellt werden.

Beachten Sie bei der Entsorgung der verbrauchten Batterien allegeltenden lokalen und überregionalen Regelungen.

Auf allen Geräteseiten muß ein Zwischenraum von ungefähr 0,1meter vorhanden sein.

Auf das Gerät dürfen keine mit Flüssigkeiten gefüllte Behälter, wieetwa eine Vase, gestellt werden.

Wenn der Schalter ausgeschaltet ist (OFF-Position), ist das Gerätnicht vollständig vom Stromnetz (MAINS) abgetrennt.

Um dieses Gerät vollständig von der Stromversorgung abzutrennen, ziehen Sie bitte den Netzstecker von der Wandsteckdose ab.

Stellen Sie bei der Aufstellung des Gerätes sicher, dass die zu verwendende Wechselstrom-Steckdose leicht zugänglich ist.

Italiano

AVVERTENZE

Non maneggiare l'adattatore CA con le mani umide.

Non coprire le fessure di ventilazione con tovaglie, giornali, tende od oggetti analoghi.

Non posare sull'apparecchio sorgenti di fiamme scoperte qualicandele accese.

Smaltire le pile usate in conformità alle norme governative o disposizioni ambientali vigenti nel proprio paese o zona.

Lasciare 0,1 metro liberi tutto intorno l'unità.

Non mettere sull'apparecchiatura alcun contenitore di liquido, come ad esempio dei vasi.

Quando l'interruttore è nella posizione OFF, l'apparecchiatura non è completamente scollegata da MAINS.

Per scollegare definitivamente questo prodotto dalla rete di alimentazione elettrica, togliere la spina dalla relativa presa.

Durante l'installazione, assicurarsi che la presa in CA utilizzata sia facilmente raggiungibile.

Português

ADVERTÊNCIAS

Não toque no adaptador de AC com as mãos molhadas.

Não cobrir os orifícios de ventilação com objectos tais como toalhas de mesa, jornais, cortinas, etc.

Não colocar chamas abertas tais como velas acesas, sobre o aparelho.

Ao deitar fora as pilhas usadas, favor observar os regulamentos governamentais ou as regras com respeito ao meio ambiente que se aplicam no seu país ou área de residência.

Deixar um espaço de cerca de 0,1 metro ao redor do aparelho.

Não colocar recipientes com água, tal como vasos, sobre o aparelho.

Quando o interruptor está na posição OFF, o equipamento não fica totalmente desligado de MAINS.

Para desligar totalmente este produto da corrente, desligue a ficha da tomada de parede.

Quando instalar este produto, certifique-se de que a tomada AC que está a utilizar pode ser facilmente acedida.

Svenska

VARNINGAR

Hantera inte nätadaptern med våta händer.

Täck inte för ventilationsöppningarna med några föremål som till exempel bordsdukar, dagstidningar, gardiner e.d.

Inga föremål med öppen låga, som till exempel tända stearinljus, bör placeras på utrustningen.

Följ de lagar och miljöskyddsråd som gäller i det land eller området där du bor när du gör dig av med batterier.

Se till att det finns omkring 0,1 meter fri plats runt omkring enheten.

Inga objekt som är fyllda med någon vätska, till exempel blomstervaser, bör placeras på apparaten.

Även om strömbrytaren står i det avstängda läget OFF, så är utrustningen inte helt bortkopplad från det elektriska nätet (MAINS).

Koppla loss stickproppen från eluttaget för att helt skilja produkten från nätet.

Vid installationen av produkten ska du se till att eluttaget den ansluts till är nära utrustningen.

Nederlands

WAARSCHUWINGEN

Raak de netspanningsadapter niet met natte handen aan.

Bedek de ventilatieopeningen niet met enige voorwerpen, zoals tafelkleden, kranten, gordijnen, enz.

Plaats geen brandende voorwerpen, zoals kaarsen, op het apparaat.

Volg bij het weggooien van verbruikte batterijen de overheidswetgeving of milieuvorschriften op die van kracht zijn in het land of de regio waarin u zich bevindt.

Zorg dat er 0,1 meter vrije ruimte rond het toestel is.

Plaats geen voorwerpen met een vloeistof erin, zoals een bloemenvaas, op het apparaat.

Als de schakelaar op OFF staat, is het apparaat niet volledig losgekoppeld van de netspanning (MAINS).

Om de voeding van dit product volledig te onderbreken moet de stekker uit het stopcontact worden getrokken.

Let er bij het plaatsen van dit product op dat het te gebruiken stopcontact goed bereikbaar is.

A NOTE ABOUT RECYCLING:

This product's packaging materials are recyclable and can be reused. Please dispose of any materials in accordance with the local recycling regulations.

When discarding the unit, comply with local rules or regulations.

Batteries should never be thrown away or incinerated but disposed of in accordance with the local regulations concerning chemical waste.

This product and the accessories packed together constitute the applicable product according to the WEEE directive except batteries.

English



UNE REMARQUE CONCERNANT LE RECYCLAGE:

Les matériaux d'emballage de ce produit sont recyclables et peuvent être réutilisés. Veuillez disposer de tout matériau conformément aux règlements de recyclage locaux.

Lorsque vous mettez cet appareil au rebut, respectez les lois ou réglementations locales.

Les piles ne doivent jamais être jetées ou incinérées, mais mises au rebut conformément aux règlements locaux concernant les déchets chimiques.

Ce produit et les accessoires emballés ensemble sont des produits conformes à la directive DEEE sauf pour les piles.

Français



ACERCA DEL RECICLAJE:

Los materiales de embalaje de este producto son reciclables y se pueden volver a utilizar. Disponga de estos materiales siguiendo los reglamentos de reciclaje de su localidad.

Cuando se deshaga de la unidad, cumpla con las reglas o reglamentos locales.

Las pilas nunca deberán tirarse ni incinerarse. Deberá disponer de ellas siguiendo los reglamentos de su localidad relacionados con los desperdicios químicos.

Este producto junto con los accesorios empaquetados es el producto aplicable a la directiva RAEE excepto pilas.

Español



HINWEIS ZUM RECYCLING:

Das Verpackungsmaterial dieses Produktes ist für zum Recyceln geeignet und kann wieder verwendet werden. Bitte entsorgen Sie alle Materialien entsprechend der örtlichen Recycling-Vorschriften.

Beachten Sie bei der Entsorgung des Gerätes die örtlichen Vorschriften und Bestimmungen.

Die Batterien dürfen nicht in den Hausmüll geworfen oder verbrannt werden; bitte geben Sie die Batterien gemäß örtlichen Bestimmungen an den Sammelstellen oder Sondermüllplätzen ab.

Dieses Produkt zusammen mit den Zubehörteilen ist das geltende Produkt der WEEE-Direktive, davon ausgenommen sind die Batterien.

Deutsch



NOTA RELATIVA AL RICICLAGGIO:

I materiali di imballaggio di questo prodotto sono riutilizzabili e riciclabili. Smaltire i materiali conformemente alle normative locali sul riciclaggio.

Per smaltire l'unità, osservare la normativa in vigore nel luogo di utilizzo.

Non gettare le batterie, né incenerirle, ma smaltirle conformemente alla normativa locale sui rifiuti chimici.

Questo prodotto e gli accessori inclusi nell'imballaggio sono applicabili alla direttiva RAEE, ad eccezione delle batterie.

Italiano



UMA NOTA SOBRE A RECICLAGEM:

Os materiais de embalagem deste produto são recicláveis e podem ser reutilizados. Elimine quaisquer materiais de acordo com as normas de reciclagem locais.

Quando eliminar a unidade, obedeça às regras ou normas locais.

As pilhas nunca devem ser deitadas fora ou incineradas, mas sim eliminadas de acordo com as normas locais relativas aos resíduos químicos.

Este produto e os respectivos acessórios embalados em conjunto constituem o produto aplicável de acordo com a directiva WEEE, excepto as pilhas.

Português



EN KOMMENTAR OM ÅTERVINNING:

Produktens emballage är återvinningsbart och kan återanvändas. Kassera det enligt lokala återvinningsbestämmelser.

När du kasserar enheten ska du göra det i överensstämmelse med lokala regler och bestämmelser.

Batterier får absolut inte kastas i soporna eller brännas. Kassera dem enligt lokala bestämmelser för kemisktavfall.

Denna apparat och de tillbehör som levereras med den är de som uppfyller gällande WEEE-direktiv, med undantag av batterierna.

Svenska



EEN AANTEKENING WAT BETREFT HET RECYCLEREN:

Het inpakmateriaal van dit product is recycleerbaar en kan opnieuw gebruikt worden. Er wordt verzocht om zich van elk afvalmateriaal te ontdoen volgens de plaatselijke voorschriften.

Volg voor het wegdoen van de speler de voorschriften voor de verwijdering van wit- en bruingoed op.

Batterijen mogen nooit worden weggegooid of verbrand, maar moeten volgens de plaatselijke voorschriften betreffende chemisch afval worden verwijderd.

Op dit product en de meegeleverde accessoires, m.u.v. de batterijen is de richtlijn voor afgedankte elektrische en elektronische apparaten (WEEE) van toepassing.

Nederlands



Table of Contents

Package Contents	3	Basic Playback Operation	26
Introduction	4	Connection Diagram	26
Quick Start Guide	6	Playback Procedure.....	26
Names and Functions	8	Access from File List.....	27
Front	8	Search	28
Left.....	10	Skip Back.....	28
Right	11	Display	29
Top	12	Advanced Features	32
Bottom	12	Microphone(s).....	32
Rear Back	13	Low Cut Filter.....	33
Preparations Before Use	14	Silent Skip.....	33
AC adapter connection	14	Manual Track	33
Using batteries.....	14	Auto Track.....	33
Installing a memory card.....	17	Copy Segment	34
Removing a memory card.....	17	Key Lock.....	35
Clock Setting.....	18	Remote	36
Font Size.....	19	USB mode	37
Basic Recording Operation	20	How to connect via the USB port.....	37
Connection Diagram	20	Diagram of file structure.....	38
Recording Procedure.....	20	Menu	39
Audio Input for Recording	22	Menu List	39
Recording Format	23	Preset Load	40
Recording Time Chart.....	24	Preset Save	41
Recording Level Control	25		

Utility Menu	42
File Rename	42
File Delete.....	43
Card Format.....	44
Preset Menu	45
Table of Preset.....	46
1. Input	47
2. Rec Format	47
3. Rec Channel	48
4. Input Jack.....	48
5. Sample Rate	49
6. Manual Track	49
7. Auto Track.....	50
8. Silent Skip	50
9. Level Control.....	51
10. Mic Attenuator	51
11. Low Cut.....	52
12. Mic Power	52
13. Level LED	53
14. Skip Back	53
15. File Sort.....	54
16. Date Form	54
17. Font Size.....	55
18. Auto Power Off.....	55
19. Battery.....	56
20. Key Lock	56
21. LED	57
22. Brightness	57

23. Machine ID.....	58
24. Default.....	59
Troubleshooting.....	60
Error Message.....	61
Specifications	62
Limited Warranty.....	63

Package Contents

- PMD620

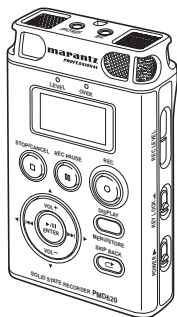

- User Guide
- CD-ROM
- Handy Strap

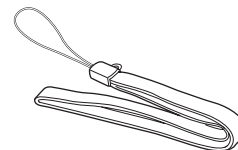

- Audio cable

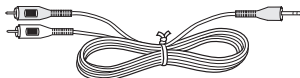

- Customer Registration Document (USA only)
- Tripod Adapter

- USB cable

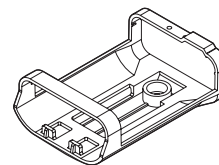
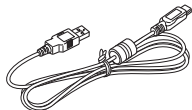

- AC adapter



- SD Card



Introduction

Thank you for selecting the Marantz Professional PMD620 Handheld Solid State Recorder.

The PMD620 is an audio recorder that records in digital audio formats onto a SD (Secure Digital) memory card.

SD cards, also used in digital cameras, are widely available at consumer electronics retailers and computer resellers.

Features

- Stereo (2 channels) and mono (1 channel) audio recording and playback.
- Audio inputs may be from :
 - the built-in microphone(s),
 - condenser or dynamic microphone(s) connected to the MIC IN jack, or
 - line level audio sources connected to the LINE IN jack.
- Audio outputs may be from :
 - the built-in speaker,
 - headphones connected to the PHONES jack, or
 - analog audio devices such as an amplifier or other devices connected to the LINE OUT jack.
- Records onto various types of SD cards.

- Computer compatible
The PMD620 records directly onto SD cards.
Recordings can be transferred to your desktop or laptop computer by removing the SD card from the PMD620 or by connecting the PMD620 to your computer via the USB port. Audio recorded in the popular MP3 compression format is directly available for intranet or internet file sharing.
MS-DOS™ and Windows compatible file system.
- Easy one control recording
Simply press the **REC** button.
- Automatic recording
The PMD620 can be set to stop recording when there is silence (Silent Skip) and automatically start when sound resumes.
- Manual and automatic record level control (ALC).
- Different recording formats :
 - Compressed recording using MP3 (MPEG1 Layer **III**) mono and stereo. MP3 compressed at 64/128/192kbps (Stereo) or 32/64/96kbps (Mono).
 - Uncompressed recording using 16/24-bit linear PCM (Pulse Code Modulation).
- Copy Segment
Copy Segment works just like the copy and paste function of your standard word processing program. It allows you to “highlight” a section of a file by setting an in point and an out point, and then paste that section into a new file without destroying the original file(s).
- Data secured
The recorded audio data until the recording stops is kept even if the power is interrupted suddenly during recording.

Quick Start Guide

Follow the instructions on this page to Quick Start your new PMD620 Solid State Recorder and begin recording. The PMD620 comes with factory preset defaults for MP3 recording using internal microphones.

1. Unpack the AC adapter and the PMD620
2. Setup the power supply
 - Use either the provided AC adapter or batteries.
 - You can use 2 AA type batteries of Alkaline, or Nickel-Metal Hydride.

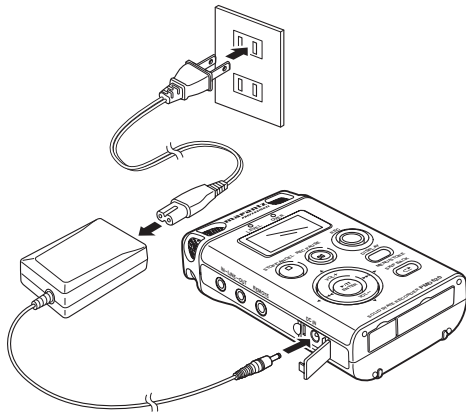

3. Slide and hold the **POWER** switch

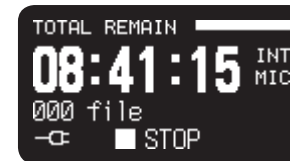
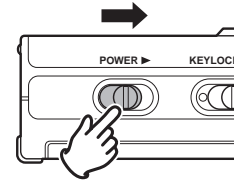

4. Press the **REC** button to begin recording

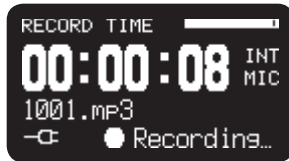
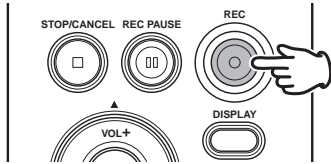

5. Press the **STOP/CANCEL** button to stop recording

6. Press the **▶/||/ENTER** button to play the just recorded file via headphones or speaker.

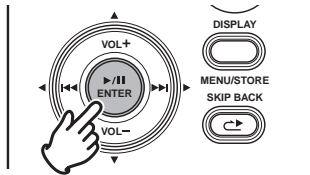

7. Press the **▶/||/ENTER** button again to pause playback.

8. Press the **STOP/CANCEL** button to stop playback

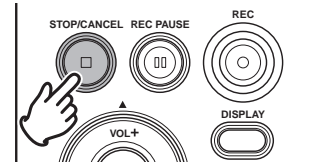

- For other recording condition, see page 20.
- For the clock setting, see page 18.
- For to select the display font size or brightness of the display, see page 45.

Names and Functions

Front

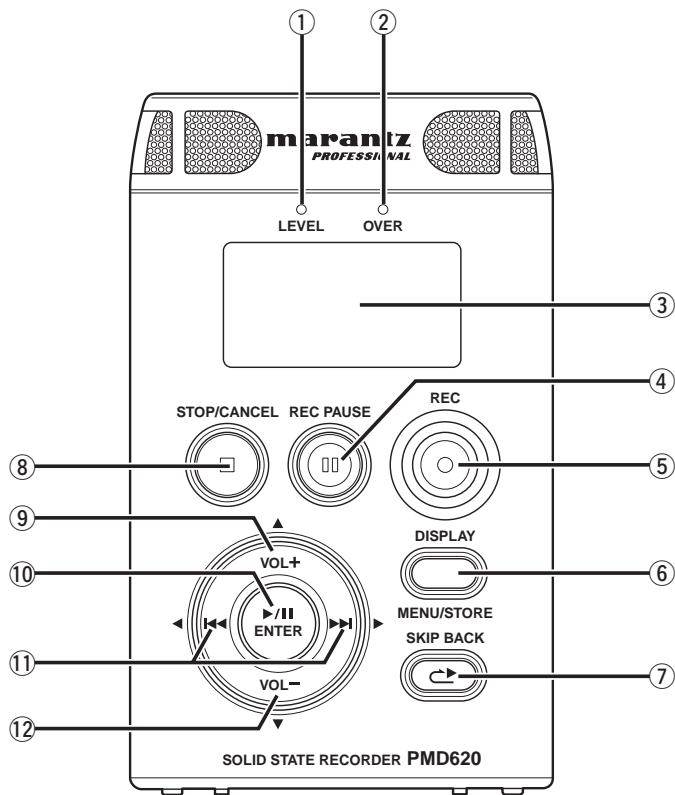

① LEVEL LED (Green)

When a sound is input during Record or Rec-Pause mode, it turns on. A level to turn on is decided in presetting. (P.53)

② OVER LED (Red)

When a sound is over peak level during Record or Rec-Pause mode, it turns on.

③ DISPLAY

The display shows information of the PMD620. (P.29)

④ REC PAUSE button

Press to enter the Rec-Pause mode from Stop or Record mode.

⑤ REC button

Press to start recording from Stop or Rec-Pause mode. The **REC** button also works to create new file during recording if the "Manual Track" in the menu is placed in "On".

Press to set IN/OUT point for Copy Segment function during Playback or Play-Pause mode. (P.34)

⑥ **DISPLAY/MENU/STORE button**

Press to change the display contents like the time information with toggle operation. The content is different depending on each operation mode. (☞ P.29)
From Stop mode press and hold to access the menu. The menu lets you set or change recording and playback parameters, such as changing inputs and setting the Date and Time. During the menu mode, press to exit the menu mode with saving preset changes. (☞ P.39)

⑦ **SKIP BACK button**

Press to skip back during Playback or Play-Pause mode.

⑧ **STOP/CANCEL button**

Press to stop the Playback or Record mode and to release the Play-Pause or Rec-Pause mode. During menu mode, press to exit menu mode without saving preset changes.

⑨ **VOL + button**

Press to make a level big of both headphones and speaker.
During menu mode, this button is used to change item.

⑩ **▶/II/ENTER button**

From stop, press to begin playback.
During Playback mode, press to pause playback. Also, if this button is pressed when playback is paused, playback restarts.
During Menu mode, this is used to decide the choice.

⑪ **I◀◀ button**

- In Stop, Playback or Play-Pause mode, press to choose the file (Jump to previous file)
- In Play-Pause mode, press and hold this for high speed reverse searching without audio.(Search -)
- In Playback mode, press and hold this to "rewind" and do a 2X speed search. (Audible Search -)

▶▶I button

Same as I◀◀ button except a difference of a direction.

⑫ **VOL – button**

Press to make a level small of both headphones and speaker.
During menu mode, this button is used to change item.

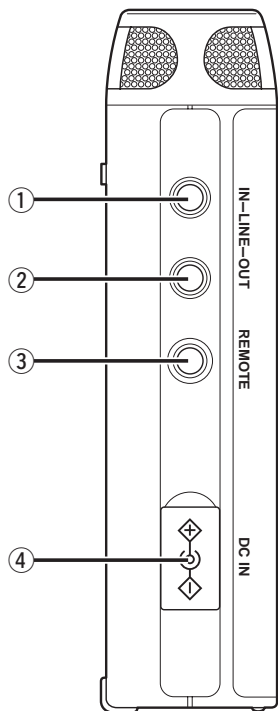

- ① **LINE IN jack**
Insert an audio cable plug connected to an external audio device into this jack to input the signals output from the external device into the recorder.
- ② **LINE OUT jack**
Insert an audio cable plug connected to an external audio device into this jack to output audio signals to an external device (amp, etc.).
- ③ **REMOTE jack**
Connect microphone remote RC600PMD (sold separately) to this jack. There is a recording indicator lamp on the RC600PMD.
- ④ **DC IN jack**
Insert the provided AC adapter plug. The power supply is DC5V, 1.5A.
If the AC adapter plug is inserted while using the recorder on battery power, the recorder will automatically switch to adapter power. Also, if the AC adapter plug is removed, the recorder will automatically switch to battery power.

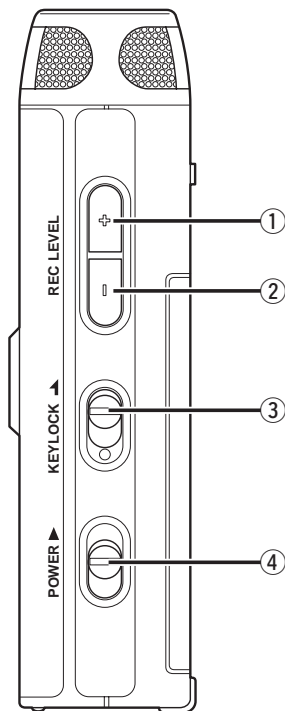

- ① **REC LEVEL + button**
Press to make a level big of input audio during Record or Rec-Pause mode.
- ② **REC LEVEL – button**
Press to make a level small of input audio during Record or Rec-Pause mode.
- ③ **KEY LOCK switch**
Slide switch for the Key Lock On and Off control.
- ④ **POWER slide switch**
Slide and hold to turn power On or Off.
During Record and Rec-Pause mode, the **POWER** switch is invalid.

Top

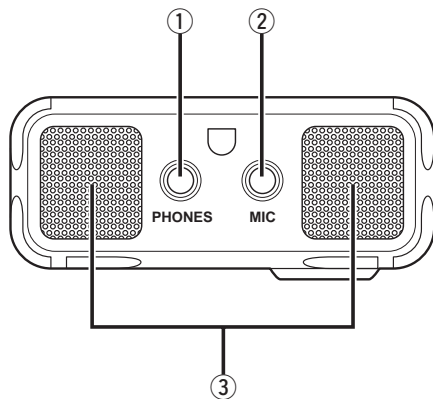

① **PHONES jack**

Insert the stereo headphones plug here.

② **MIC jack**

Insert the external microphones plug.

③ **Internal MIC**

Stereo internal microphones.

Bottom

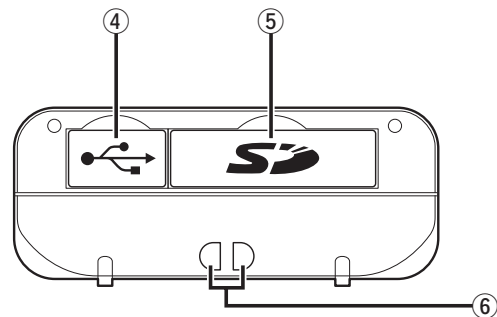

④ **USB compartment**

Pull the lid to connect PC via USB cable.

⑤ **Card compartment**

Pull the lid to access the SD card.

⑥ **Strap hole**

This hole is for handy strap.

Rear Back

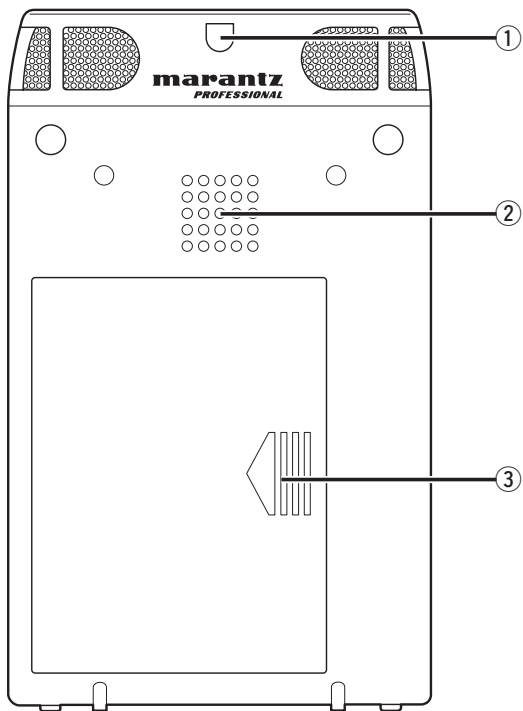

- ① **Strap hole**
This hole is for handy strap.
- ② **Speaker**
Monaural build-in speaker.
- ③ **Battery compartment**
Slide and pull the lid to open the Battery compartment.

Preparations Before Use

AC adapter connection

When using the recorder with the provided AC adapter, follow the procedure below to connect the AC adapter.

If you wish to use batteries, please refer to the Using batteries section.

Notes:

- Only use the AC adapter that is provided with the recorder.
- Running the recorder on DC power without using the provided AC adapter will cause damage to the recorder.

1. Connect the plug of AC power pack into the DC IN jack on the recorder.
2. Connect the Power cord to a regular household plug socket.

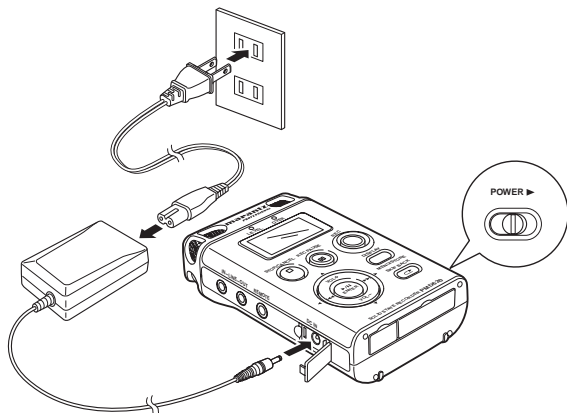

Using batteries

If you wish to run the recorder on battery power, follow the procedure below to install batteries into the recorder. The following types of battery can be used.

- Alkaline batteries (AA type)
- Nickel-Metal Hydride batteries (AA type)

Notes:

- When alkaline batteries (1450mAh type) are used recording: about 4 hours
- When running the recorder on batteries, always set the battery type in the preset menu to the correct setting for the batteries used. (☞ P.56)
- If the batteries run out during recording, recording automatically stops and the file information is updated before the recorder shuts down.
- AC adapter is priority than battery. In both power driven, when the AC adapter is taken off, the battery can backup and keep the all behavior on the PMD620.

1. Check that the power is turned off.
2. Slide and pull the battery compartment.

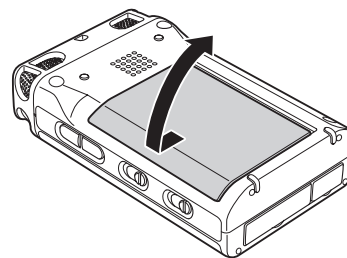

3. Insert 2 batteries into the recorder correctly as shown in the diagram below, while paying attention to the polarity displays (⊕: plus, and ⊖: minus).

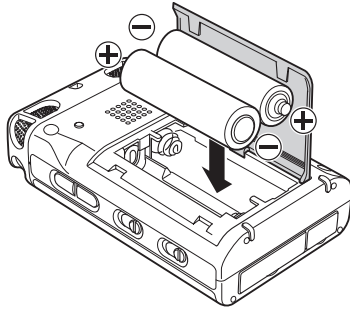

4. Close the battery compartment.

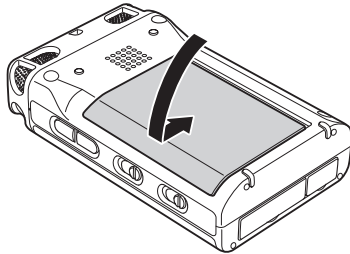

5. Slide and hold the **POWER** switch to turn on.

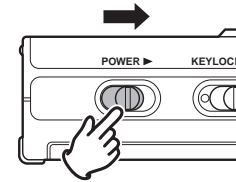

6. Set the battery type for the recorder to match the type of batteries you are using. (P.56)





Safety cautions on handling batteries

Always follow the points below when using batteries to avoid electrolyte leakage, overheating, fire, rupturing, ingestion, etc.

- Electrolyte leakage or corrosion may occur if batteries are kept inside the recorder for prolonged periods of time. If the recorder is not to be used for a prolonged period, remove the batteries to prevent electrolyte leakage.
- Make sure that the + and – markings on the batteries are aligned with the corresponding markings in the battery case and the battery holder.
- Do not insert old or exhausted batteries into the recorder.
- Do not mix the type of battery, and do not use both old and new batteries together.
- If the recorder does not operate correctly, replace the old batteries with new ones.
- If electrolyte has leaked, thoroughly wipe the inside of the battery holder, and then insert new batteries.

Battery remaining indicator

The recorder operates using commercially available AA size alkaline or Ni-MH batteries. During operation, the battery remaining indicator is as follows.

Indicator	Meaning
	There is still ample battery power remaining.
	The amount of battery power remaining has decreased to approximately half.
	Only a small amount of battery power remaining.
	There is not enough battery power remaining to record or playback. Either replace the batteries with new ones, or recharge the rechargeable batteries. If you continue recording while this indicator is flashing, recording/playback will stop, and the recorder will shut down.
	The AC adapter is being used. The adapter power supply is valid.

Installing a memory card

The PMD620 records onto various types of SD cards.

1. Check that the power is turned off.
2. Pull the SD card lid.

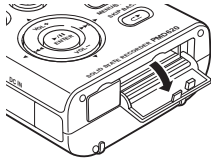

3. Fully insert the SD card.

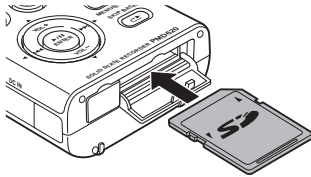

4. Close the SD card lid.

Removing a memory card

1. Check that the power is turned off.
2. Pull the SD card lid.
3. Push the card, then pull it to remove it.

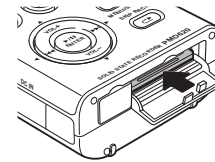

4. Close the SD card lid.

Notes:

- If the SD card lid opens while power is on, “Door Open” is displayed.
- If recording is in progress, opening the SD card lid automatically stops recording and writes critical file information to properly close the file.

Clock Setting

Set the current time (year, month, day, hour, minute).

1. From Stop, press and hold the **DISPLAY** button for three seconds.

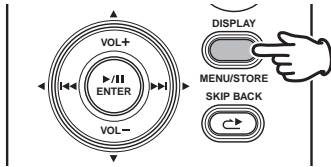

2. Press the **VOL +** or **VOL -** button to select "Time/Date".



3. Press the **>|| / **ENTER** button to enter the Time/Date setting.**

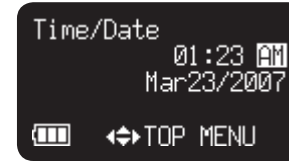

- Press the **STOP/CANCEL** button to cancel.
- Press the **◀◀** or **▶▶** button to select the item.
- When the hour is set, press the **◀◀** button to return to the Top Menu.
- When the year is selected, the **▶▶** button does not work.
- Press the **VOL +** or **VOL -** button to select the value.

4. Press the **DISPLAY** button to write on the Real Time Clock.

Note:

If it happens to be the date which does not exist such as Feb. 31, it gets revised as back to Feb. 28.

Font Size

You can increase the font size of the text on the file list screen and preset setting screen.

1. From Stop, press and hold the **DISPLAY** button for 3 seconds.

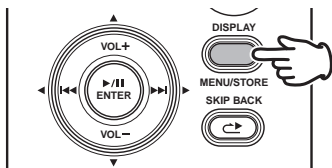

2. Press the **VOL +** or **VOL -** button to select “Preset Menu”. Then press the **▶/||/ENTER** button to accept.



3. Press the **VOL +** or **VOL -** button to select Preset 1, 2 or 3. Then press the **▶/||/ENTER** button to accept the selected Preset.

4. Press the **VOL +** or **VOL -** button to select the Font Size item. Then press the **▶▶** or **◀◀** button to tab through the Font Size choices (Large or Small).
5. Press the **DISPLAY** button to store the changes.
 - Press the **STOP/CANCEL** button to cancel.

Note:

For example, the file list screens are follows.

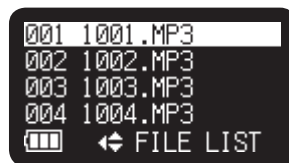

Large font

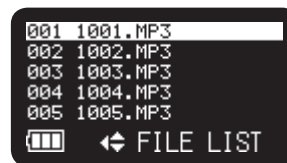

Small font

Basic Recording Operation

Connection Diagram

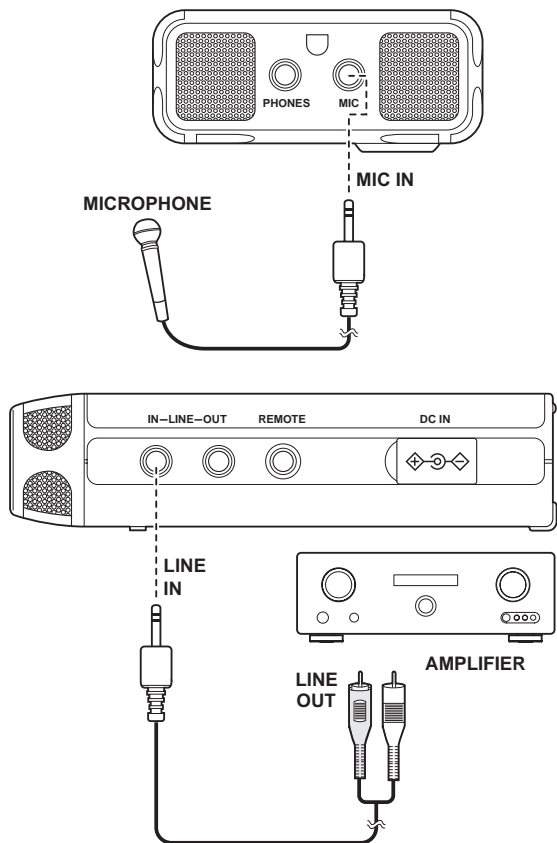

Recording Procedure

1. Slide and hold the **POWER** switch to turn on.

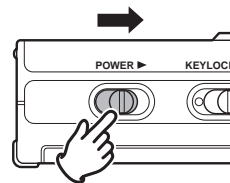

2. Press the **REC** button to begin recording.

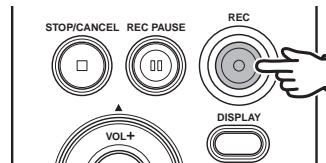

- The Rec indicator will be lit and steady while recording.

- The display will show the information display of recording.
(☞ P.30)

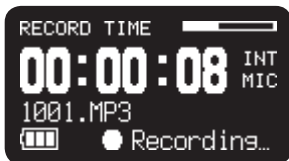

3. Press the **REC PAUSE** button to pause recording.

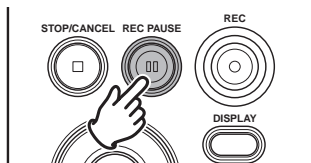

4. Press the **STOP/CANCEL** button to stop recording and end the file (close the audio file).

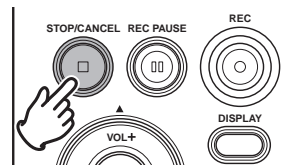

The display switches to information about the just recorded file. You can press the **▶/||/ENTER** button to play the just recorded file, or push the **STOP/CANCEL** button again to enter Stop mode. Then pressing the **▶/||/ENTER** button will play the beginning of the first audio file.

Audio Input for Recording

The audio input for recording can be set from the "Input" menu. (P.47)

If "Input" of menu is Auto and External MIC is connected, Recording source is External MIC. When LINE jack is connected, Recording source is LINE audio. When the both connected at the same time the External MIC is active as priority.

You can perform 4 types of recording using combinations of the Preset "Rec Channel" (P.48) and "Input Jack" (P.48).

Rec Channel Setting	Input Jack Setting	Description
Stereo	Stereo	The L channel and R channel input is recorded to a stereo file. This is standard stereo recording.
	Mono	The input audio is recorded to the L channel and R channel of the stereo file. The same audio is recorded into the L channel and R channel of the stereo file. When the input is stereo, the input is only recorded to the L channel.
Mono	Stereo	Audio mixed from the L channel and R channel is recorded to a monaural file.
	Mono	The input audio is recorded to a monaural file. When the input is stereo, it is only recorded to the L channel.

Recording Format

The PMD620 can record in several compression algorithms.

- Compressed recording using MP3 or uncompressed recording 16/24-bit linear PCM (P.47).
- Stereo or Mono format. (P.48).

Rec Format	Sample Rate	Channel	Bitrates	File Extension
MP3-H	44.1KHz	Stereo	192 kbps	mp3
		Mono	96 kbps	mp3
	48KHz	Stereo	192 kbps	mp3
		Mono	96 kbps	mp3
MP3-M	44.1KHz	Stereo	128 kbps	mp3
		Mono	64 kbps	mp3
	48KHz	Stereo	128 kbps	mp3
		Mono	64 kbps	mp3
MP3-L	44.1KHz	Stereo	64 kbps	mp3
		Mono	32 kbps	mp3
	48KHz	Stereo	64 kbps	mp3
		Mono	32 kbps	mp3
PCM-16	44.1KHz	Stereo	1411 kbps	wav
		Mono	705 kbps	wav
	48KHz	Stereo	1536 kbps	wav
		Mono	768 kbps	wav
PCM-24	44.1KHz	Stereo	2116 kbps	wav
		Mono	1058 kbps	wav
	48KHz	Stereo	2304 kbps	wav
		Mono	1152 kbps	wav

The record file of PCM is BWF(Broadcast Wave Format).

Recording Time Chart

All times are approximated record times.

Different media manufacturers allow more or less space for error correction and the like on their respective products.

Recording Time (hours : minutes)

Stereo channel

Settings	Card Size				
	256MB	512MB	1GB	2GB	4GB
MP3-H	2:57	5:54	11:48	23:36	47:12
MP3-M	4:26	8:52	17:44	35:28	70:56
MP3-L	8:52	17:44	35:28	70:56	141:52
PCM-16(44.1kHz)	0:24	0:48	1:36	3:12	6:24
PCM-16(48kHz)	0:22	0:44	1:28	2:56	5:52
PCM-24(44.1kHz)	0:16	0:32	1:04	2:08	4:16
PCM-24(48kHz)	0:14	0:28	0:56	1:52	3:44

Mono channel

Settings	Card Size				
	256MB	512MB	1GB	2GB	4GB
MP3-H	5:54	11:48	23:36	47:12	94:24
MP3-M	8:52	17:44	35:28	70:56	141:52
MP3-L	17:44	35:28	70:56	141:52	283:44
PCM-16(44.1kHz)	0:48	1:36	3:12	6:24	12:48
PCM-16(48kHz)	0:44	1:28	2:56	5:52	11:44
PCM-24(44.1kHz)	0:32	1:04	2:08	4:16	8:32
PCM-24(48kHz)	0:28	0:56	1:52	3:44	7:28

Recording Level Control

The recording level control lets you select the type of input level control.

– At the Manual Level Control

When Manual is set in the Level Control setting, press the **REC LEVEL +** or **REC LEVEL –** button to control the audio input level. The optimum record level is when the level meter goes as close to 0dB as possible but does not go OVER. When Level display is off, press the **REC LEVEL +** or **REC LEVEL –** button to display the level information for 1 seconds without changing recording level.

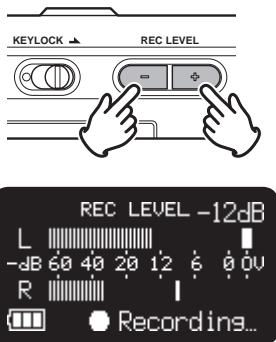

– At ALC (Automatic Level Control)

The PMD620 automatically responds to changes in input level. The **REC LEVEL** controls do not work when the ALC is selected. Set the Level Control of the preset menu "ALC" (P.51).

Basic Playback Operation

Connection Diagram

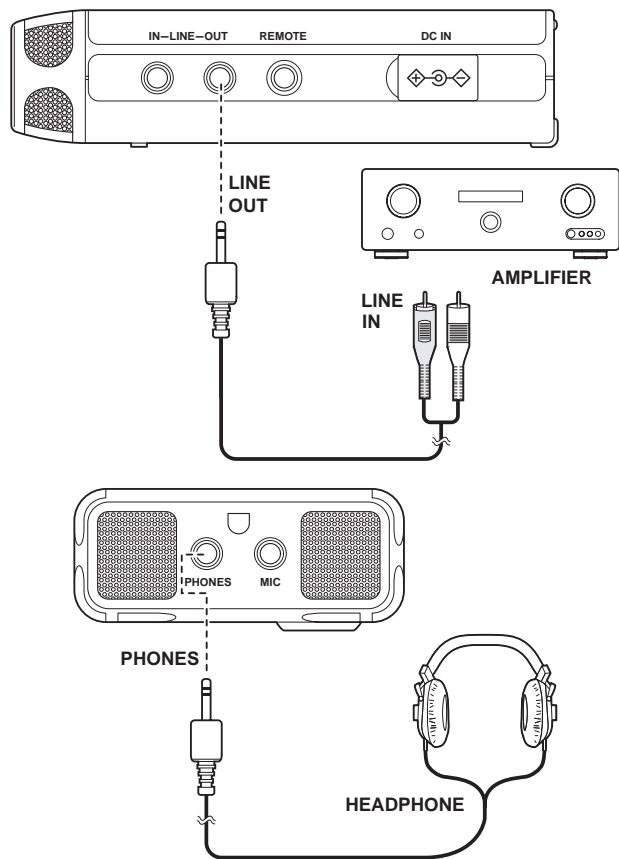

Playback Procedure

1. Slide and hold the **POWER** switch to turn on.

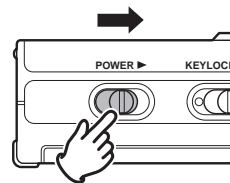

2. Press the **◀◀** or **▶▶** button to choose the file.

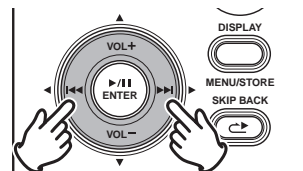

3. Press the ►/||/ENTER button to begin playback.

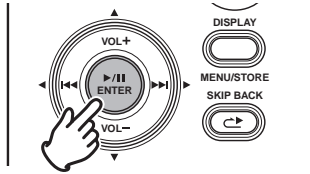

4. Press the ►/||/ENTER button again to pause playback.
5. Press the STOP/CANCEL button to stop playback

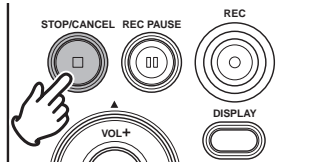

You can press the ►/||/ENTER button to play the just played file, or push the **STOP** button again to enter Stop mode. Then pressing the ►/||/ENTER button will play the beginning of the first audio file.

Note:

The file sort order can be changed using the preset “File Sort”. (P.54)
 When set to Alphabet, files are sorted in order of symbol, number, and alphabet. When set to Time/Date, audio files are sorted into the order in which they were created.

Access from File List

There are 2 ways to select the file you want to playback. Either use the ◀◀ or ▶▶ buttons during Stop mode, or select the files from the File List.

1. From Stop, press and hold the **DISPLAY** button for three seconds.

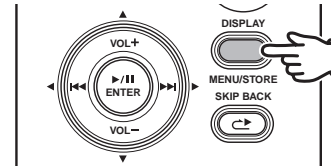

2. Press the ►/||/ENTER button to display the file list.

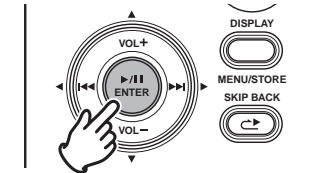

3. Press the **VOL +** or **VOL -** button to select the audio file.

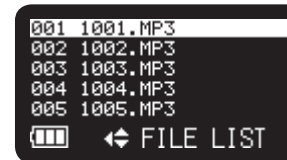

4. Press the ►/II/ENTER button to begin playback the selected file.

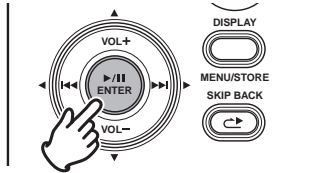

- Press the ◀◀◀ button to return to the Menu list.
- Press the **STOP/CANCEL** button to exit the menu.

Note:

If the text is small and difficult to see, you can increase the font size using the preset “Font Size”. (P.55)

Search

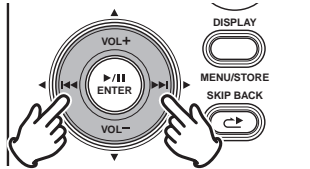

In Play-Pause mode, press and hold the ◀◀◀ or ►►► button for high speed searching without audio. 10X searching speed from beginning to 3 seconds, and 140X speed over 3 seconds until release the button. When you release the button, the recorder returns to playback paused.

If the end of the file is passed with ►►► button still held down, search moves to the next file and continues searching in the forward direction.

If the tip of the file is passed with ◀◀◀ button still held down, search moves to the previous file and continues searching in the reverse direction.

During playback, press and hold the ◀◀◀ button to “rewind” and do a 2X speed audible search in the reverse direction.

During playback, press and hold the ►►► button to “fast forward” and do a 2X speed audible search in the forward direction. Release to return to normal forward playback.

Skip Back

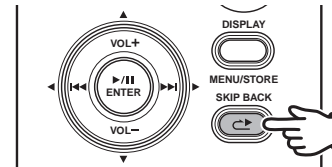

Press the **SKIP BACK** button during playback or pause to return the amount of time set in the preset Skip Back from the current playback point. (P.53)

Display

Press the **DISPLAY** button to alternate information displays. Displays are slightly different in Stop, Record and Playback mode.

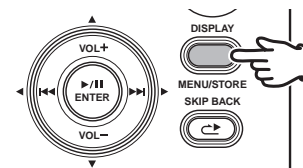

During Stop mode:

① Total Remain



② Current Time/Date



③ Record Setup



① Total Remain (Default display)

TOTAL REMAIN

Total remain time — 12:34:56

Number of files — 023 files

Battery icon — [Battery Icon]

Remaining space of the card. — [Progress Bar]

Input source (INT MIC/MIC/LINE) — INT MIC

Status — STOP

TIME/DATE

Current time — 01:23AM

Current date — Mar23/2007

- If "Date Form" setting in preset menu is M/D/Y, the date field shows MMMDD/YYYY.
- If "Date Form" setting is D/M/Y, the date field shows DDMMM/YYYY. (P.54)

REC SETUP

Input source (INT MIC/MIC/LINE) — INT MIC

Record Format — MP3-H

Quantization — 16bit

ALC icon — ALC

Chennel — Stereo

MP3 bitrate — 192kbes

Sample rate — 44.1kHz

AUTO TRK icon — AUTO TRK

- The MP3 bitrate is disappeared if the "Rec Format" setting is PCM.
- The ALC icon is disappeared if the "Level Cont." setting is Manual.
- The AUTO TRK icon is disappeared if the "Auto Track" setting is Off.

During Record mode:

① Record Time



② Total Remain



③ Record Setup



④ Record Level



① Record Time (Default display)

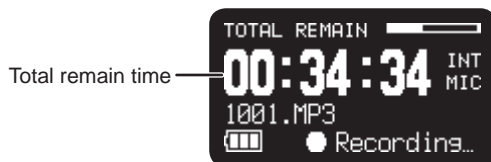

- The MP3 bitrate is disappeared if the "Rec Format" setting is PCM.
- The ALC icon is disappeared if the "Level Cont." setting is Manual.
- The AUTO TRK icon is disappeared if the "Auto Track" setting is Off.



During Playback mode:

① Elapsed Time



② Remain Time



③ File Properties



① Elapsed Time (Default display)

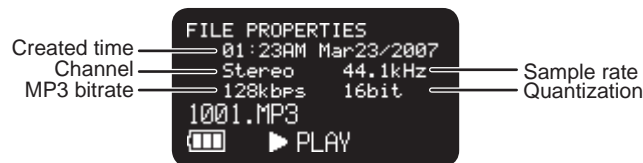
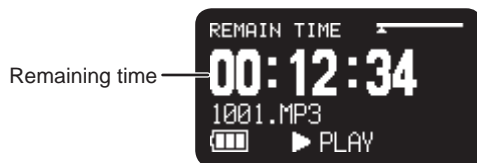

- If "Date Form" setting in preset menu is M/D/Y, the date field shows MMMDD/YYYY.
If "Date Form" setting is D/M/Y, the date field shows DDMMM/YYYY. (P.54)

Advanced Features

Microphone(s)

– Attenuator

The microphone attenuation switch permits the direct use of microphones that differ in sensitivity.

- 0dB : No microphone attenuation.
- -12dB: Input from a microphone(s) connected to the MIC jack is cut by 12dB.
- -24dB: Input from a microphone(s) connected to the MIC jack is cut by 24dB.
Setup the “Mic Attenuator” of the preset menu. (P.51)

– Mic Power

Switch “Mic Power” setting to On to provide +5V of power for a condenser microphone(s).

- On : +5V is supplied to power condenser microphone(s).
- Off : No microphone power is supplied.
Setup the “Mic Power” of the preset menu. (P.52)

Microphone recommendations

Professional condenser microphone(s) (which require additional power from either the PMD620's phantom power or from another source) are recommended because they provide greater sensitivity and higher quality audio recording.

Dynamic microphone(s) can be used, but they do not yield optimum audio quality recordings in some applications.

Consult with your local dealer to select the appropriate microphone(s) for your specific application. In many cases, they can demonstrate the various performances and characteristics of microphones for your use.

Low Cut Filter

The bass region of the input audio is cut as the audio is recorded. Set to On to reduce noise, such as the sound of the wind when recording outdoors.

Setup the “Low Cut” of the preset menu. (P.52)

Silent Skip

The Silent Skip automatically pauses recording when there is a period of silence and resumes recording when sound resumes.

“Silent Skip” menu setting permits:

- Adjusting the margin sound level that defines silence in Off, -60dB, -54dB, -38dB, -20dB.

Setup the “Silent Skip” of the preset menu. (P.50)

Manual Track

When the Manual Track (Manual Track incrementing) is On during recording, press the **REC** button to increment the audio file.

A new audio file is created at that point. The continuity of sound is not guaranteed and depends on the speed of a card or the audio file size.

Setup the “Manual Track” of the preset menu. (P.49)

Auto Track

With the Auto Track (Automatic Track incrementing) On, a new audio file is begun automatically at specified intervals of recording time. The Auto Track can be set to increment every 1, 5, 10, 15 or 30 minutes, or every 1, 2, 6, 8, 12 or 24 hours. The Auto Track makes finding a particular point in a recording easier. For example, if a new audio file begins every minute during playback, the Auto Track makes finding a particular passage easier because of the relationship between file numbers and time. During playback, you can select file number 3 to play approximately the 3rd minute of recording. To go directly to the beginning of the 10th minute, select file number 10, etc.

#	Recording time minutes:seconds
001.....	0:00 – 1:00
002.....	1:01 – 2:00
003.....	2:01 – 3:00

The continuity of sound is not guaranteed and depends on the speed of a card or the file size.

Setup the “Auto Track” of the preset menu. (P.50)

Copy Segment

Copy Segment physically turns your “highlighted” section into a new and separate file, without destroying the original source file(s).

1. During playback, press the **REC** button when the audio reaches your desired In Point.

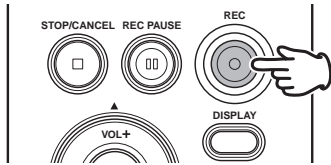

“Set as IN?” is displayed.

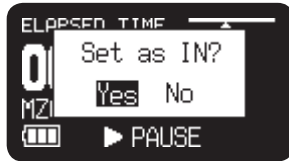

2. Press the **▶/||/ENTER** button to store the In point. “IN-” will flash in the display to indicate the In point has been stored and playback of the file resumes.

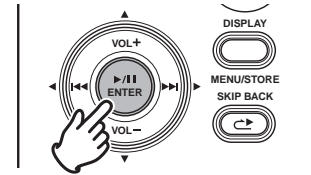

3. Continue to let the PMD620 play to your desired Out point, or use the standard transport controls like the **▶▶** or **◀◀** button to span greater time lengths.
4. When you have reached your desired Out point, press the **REC** button.

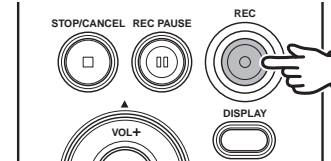

“Set as OUT?” is displayed.

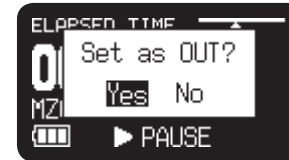

5. Press the ►/⏏/ENTER button to store the Out point.
“Copy Segment?” is displayed.

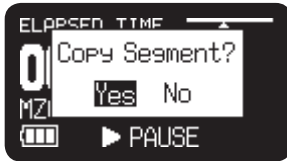

6. Press the ►/⏏/ENTER button to start the Copy process.
“Executing...” will be shown on the display. When the copy procedure is completed, the display will show “Completed” for 1 sec. and then returns to stop mode with your new file as the current file.

Notes:

- When a copy area spans across two or more files, a file is connected and copied.
- When the copy area spans across files of different “Rec Format” or “Rec Channel” setting, it can not copy.
- The copy area can not exceed 80 minutes.

Key Lock

Slide the **Key Lock** switch to lock the keys.
The key lock secures the PMD620 in the state it is in during recording, playback or stop.
During Record and Rec-Pause mode, the **POWER** switch is always invalid.

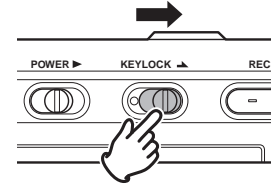

Notes:

- If “Key Lock” setting is All, only the optional remote controller RC600PMD is accepted.
 - If “Key Lock” setting is Partial, the **REC**, **REC PAUSE** and **STOP/CANCEL** buttons on the panel, and RC600PMD are accepted.
Setup the “Key Lock” of the preset menu. (P.56)
- “Key Locked” is displayed for 1 seconds when the key is pressed during key lock.



Remote

The PMD620 allows you to use an optional remote controller RC600PMD. (sold separately). The RC600PMD is designed for microphone interviews. It attaches to your microphone. The remote's five feet cord with a four contact mini plug, plugs into the PMD620. The RC600PMD does not require any menu changes for use.

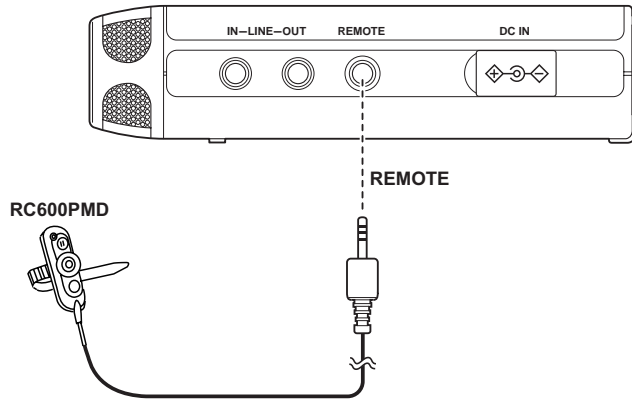

The RC600PMD includes:

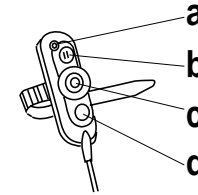

a An indicator light:

- (green) lit and steady during standby or stop
- (red) lit and steady while recording
- (flashing red) during Rec-Pause mode
- (orange) flashes for 1/2 second when an over peak level signal is input during Record or Rec-Pause mode, then it goes back to red.

b push to pause recording

c push to start/resume recording and to manually increment files

d Invalid

USB mode

The PMD620 records directly onto SD cards.

Recordings can then be transferred to your desktop or laptop computer by removing the SD card from the PMD620, or by connecting the PMD620 to your computer via the USB port.

Audio recorded in the popular MP3 compression format is directly available for intranet or internet file sharing.

Computer compatible

On your computer you can then:

- log and archive audio files
- play audio files
- save audio files to your drive

How to connect via the USB port

The SD card in the PMD620 appears as an external drive on a connected computer.

1. Power up the computer.
2. Insert an SD card.
3. Power up the PMD620.
4. During Stop mode, connect the cable to the PMD620 and your computer.

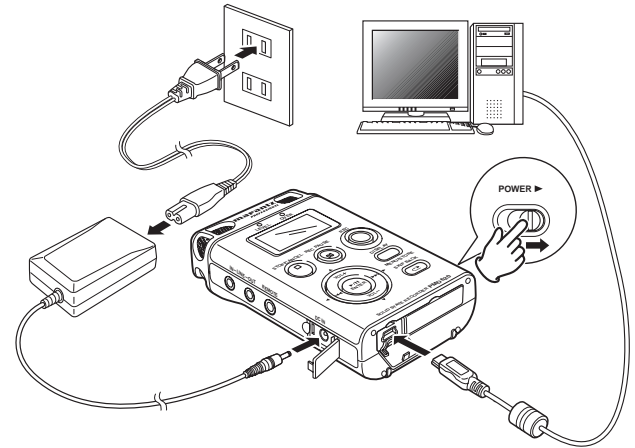

- While USB is on, a set screen is displayed.



- The SD card in the PMD620 appears as a removable device on your computer.
- The audio files are in a folder that is named MPGLANG1.

Notes:

- Check the operating system of your computer.
Windows Me, 2000, XP, Vista, MAC OS 10
- USB Bus Power activates.
- No buttons other than the **POWER** switch function.

Caution:

- Do not remove a SD card during USB mode. The Data and the SD card may be damaged.
- During recording and playback, do not connect the cable to the PMD620 and your computer. The PMD620 may turn itself off or stop, by the USB Bus Power condition.

Diagram of file structure

A folder (directory) titled MPGLANG1 will appear on your computer. Files within the MPGLANG1 folder are numbered from aaaaa001 through the number of files recorded to a maximum of aaaa999. ("aaaa" depends on the "Machine ID" parameter. The default setting of "Machine ID" is 1) The file extension will be .mp3 or .wav depending on the "Rec Format" parameter that is set for the recording.

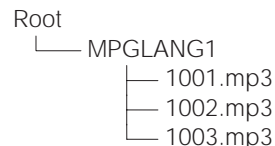

Changes made to file names or structures on your computer will prevent file recognition and playback in the PMD620.

Machine ID

An audio file has Machine ID information. This information is included in a file name. For example, if the Machine ID is "1", the first file is numbered "1001.wav" or "1001.mp3". Setup the "Machine ID" of the preset menu. (P.58)

Menu

Menu List

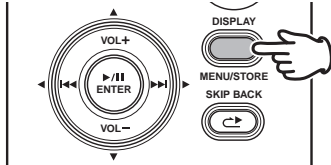

1. From Stop, press and hold the **DISPLAY** button for 3 seconds.



- Menu List appears in the display.
- The selected item is highlighted.
- When the first item is selected, press **VOL +** button to jump to the last item.
- When the last item is selected, press **VOL –** button to jump to the first item.

2. Press the **VOL +** or **VOL –** button to select the item.

3. Press the **▶/||/ENTER** button to confirm or execute the selected item.

Items and functions

#	Display	Description	Reference
1	File List	Browse audio files	Page 27
2	Utility Menu	Go to Utility menu	Page 42
3	Preset Menu	Go to Preset menu	Page 45
4	Time/Date	Adjust current time and date	Page 18
5	Preset Load	Load preset data from SD card	Page 40
6	Preset Save	Save preset data to SD card	Page 41
7	F/W Version	Displays the firmware version	–

Preset Load

Preset Load allows you to load the preset value from the SD card in the PMD620.

When performing preset load, use a SD card in which the preset contents from Preset Save (P.41) are stored.

This function is particularly useful when setting multiple PMD620s with the same settings.

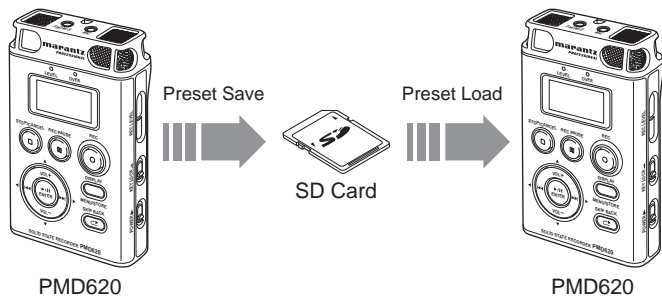

1. From Stop, press and hold the **DISPLAY** button for 3 seconds.
2. Press the **VOL +** or **VOL -** button to select “Preset Load”.

3. Press the **▶/||/ENTER** button. “Preset Load?” message is displayed.

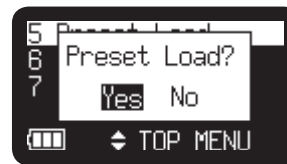

- Press the **STOP/CANCEL** button to cancel loading items and return to Stop mode.
4. While “Preset Load?” message is displayed, select “Yes” and press **▶/||/ENTER** button to load the preset value in text format from the file in a route folder on card. The title of the file load is “620preset.cfg”. During preset loading it displays “Executing...”. After the file load is completed, “Completed” is displayed for 1 second and returns to Stop mode.

Preset Save

Preset Save saves all of the preset values onto the SD card. To set the saved files onto the PMD620, perform Preset Load (see P.40).

1. From Stop, press and hold the **DISPLAY** button for 3 seconds.
2. Press the **VOL +** or **VOL –** button to select “Preset Save”.
3. Press the **▶/||/ENTER** button. “Preset Save?” message is displayed.

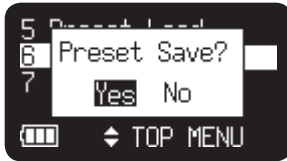

- Press the **STOP/CANCEL** button to cancel saving item and return to Stop mode.

4. While “Preset Save?” message is displayed, select “Yes” and press **▶/||/ENTER** button to output preset value in text format into the file in a route folder on card. The title of the file output is “620preset.cfg”. During preset output it displays “Executing...”. After the file output is completed, “Completed” is displayed for 1 second and returns to Stop mode.

Utility Menu

Utility menu lets you rename files, erase files and format the SD card.

1. From Stop, press and hold the **DISPLAY** button for 3 seconds.
2. Press the **VOL +** or **VOL –** button to select “Utility Menu”.
3. Press the **▶/||/ENTER** button.



- During Utility menu mode, press the **STOP/CANCEL** button to return to Stop mode.

Utility Functions

#	Display	Description	Reference
1	File Rename	Edit the name of audio file	Page 42
2	File Delete	Delete a audio file	Page 43
3	Card Format	Delete all files	Page 44

File Rename

1. From Stop, press and hold the **DISPLAY** button for 3 seconds.
2. Press the **VOL +** or **VOL –** button to select “Utility Menu”. Then press the **▶/||/ENTER** button.
3. Press the **VOL +** or **VOL –** button to select “File Rename”. Then press the **▶/||/ENTER** button.

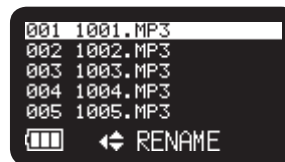

- File List appears in the display.
- Press the **◀◀** button to return to the Utility Menu.
- Press the **STOP/CANCEL** button to return to Stop mode.

4. Press the **VOL +** or **VOL –** button to select the file you want to rename. Then press the **▶/||/ENTER** button to access the rename window.

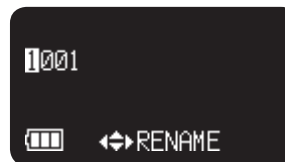

5. Rename the file title.

Text can be inserted and deleted. Press the **◀◀** or **▶▶** button to move the cursor to the place you wish to insert text into or delete text from.

To insert text

Press the **VOL +** or **VOL –** button to select the character you want to insert. When the character that you want to insert is displayed, press the **▶/||/ENTER** button to enter the character. The selected character for insertion is highlighted.

To delete text

Press the **SKIP BACK** button to delete the selected character.

6. Press the **▶/||/ENTER** button to enter the changes.

Notes:

- If there has been a file with the title changed with the **▶/||/ENTER** button exists, “Exist Title” is displayed for 1 seconds.
- If Last letter of the file title is Space(SP) character, the changed title do not include the last letter.
- Extensions are not displayed.
- If number of file title letter is more than 60, last letter is deleted when a new letter is added.
- The characters which you can insert are A a B b C c D d E e F f G g H h I i J j K k L l M m N n O o P p Q q R r S s T t U u V v W w X x Y y Z z (Space) ! “ # \$ % & ' () + , - . ; = @] ^ _ ` { } ~ 0 1 2 3 4 5 6 7 8 9.

File Delete

1. From Stop, press and hold the **DISPLAY** button for 3 seconds.
2. Press the **VOL +** or **VOL –** button to select “Utility Menu”. Then press the **▶/||/ENTER** button.
3. Press the **VOL +** or **VOL –** button to select “File Delete”. Then press the **▶/||/ENTER** button.

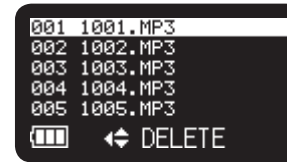

- File List appears in the display.
- Press the **◀◀** button to return to the Utility List.
- Press the **STOP/CANCEL** button to return to Stop mode.

4. Press the **VOL +** or **VOL –** button to select the file you want to delete. Then press the **▶/||/ENTER** button. “File Delete?” message is displayed.



- Press the **STOP/CANCEL** button to cancel a File Delete item and return to STOP.
5. While “File Delete?” message is displayed, select “Yes” and press the **▶/||/ENTER** button to delete the selected file. While deleting “Executing...” is displayed. “Completed” is displayed for 1 second.

Card Format

1. From Stop, press and hold the **DISPLAY** button for 3 seconds.
2. Press the **VOL +** or **VOL –** button to select “Utility Menu”. Then press the **▶/||/ENTER** button.
3. Press the **VOL+** or **VOL–** button to select “Card Format”. Then press the **▶/||/ENTER** button.
 - “Card Format?” message is displayed.

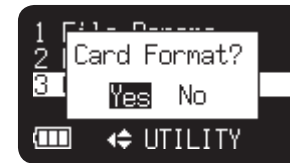

- Press the **STOP/CANCEL** button to cancel a Card Format item and return to STOP.
4. While “Card Format?” message is displayed, select “Yes” and press the **▶/||/ENTER** button to format the SD card. While formatting “Executing...” is displayed. After displaying “Completed” for a second, PMD620 return to Stop mode.

Preset Menu

You can store to 3 detailed presets on the recorder for such settings as recording input, recording format, playback mode, etc. There are 23 setting items in the preset menu, and 3 presets can be set with the desired conditions.

Preset Select allows you to select a preset number.

1. From Stop, press and hold the **DISPLAY** button for 3 seconds.
2. Press the **VOL+** or **VOL-** button to select “Preset Menu”. Then press the **▶/II/ENTER** button.

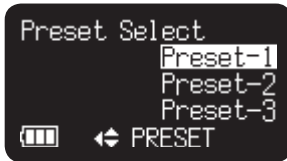

3. Press the **VOL +** or **VOL -** button to select Preset 1, 2 or 3.
4. Press the **▶/II/ENTER** button to accept the selected Preset.
5. Also press the **DISPLAY** button to store the changes, or press the **STOP/CANCEL** button to exit Menu mode without storing any changes. Or press the **▶/II/ENTER** button to access each preset items.

Table of Preset

Order	Display	Settings	Default		
			Preset-1	Preset-2	Preset-3
1	Input	Auto/INT MIC/MIC/LINE	Auto	Auto	Auto
2	Rec Format	MP3-H/MP3-M/MP3-L/PCM-16/PCM-24	MP3-M	MP3-H	PCM-24
3	Rec Channel	Stereo/Mono	Stereo	Stereo	Stereo
4	Input Jack	Stereo/Mono	Stereo	Stereo	Stereo
5	Sample Rate	44.1kHz/48kHz	44.1kHz	44.1kHz	48kHz
6	Manual Track	On/Off	On	On	On
7	Auto Track	Off/1min/5min/10min/15min/30min/1hour/2hour/6hour/8hour/12hour/24hour	Off	Off	Off
8	Silent Skip	Off/-60dB/-54dB/-38dB/-20dB	Off	Off	Off
9	Level Cont.	Manual/ALC	ALC	Manual	Manual
10	Mic Atten.	0dB/-12dB/-24dB	0dB	0dB	0dB
11	Low Cut	On/Off	Off	Off	Off
12	Mic Power	On/Off	Off	Off	Off
13	Level LED	-54dB/-38dB/-20dB/-12dB/-6dB	-12dB	-6dB	-6dB
14	Skip Back	1sec/2sec/3sec/4sec/5sec/6sec/7sec/8sec/9sec/10sec/15sec/20sec/25sec/30sec/35sec/40sec/45sec/50sec/55sec/ 60sec	3sec	3sec	3sec
15	FileSort	Alphabet/Time/Date	Time/Date	Time/Date	Time/Date
16	Date Form	M/D/Y/D/M/Y	M/D/Y	M/D/Y	M/D/Y
17	Font Size	Large/Small	Small	Small	Small
18	Auto Power Off	On/Off	On	On	On
19	Battery	Alkaline/Ni-MH	Alkaline	Alkaline	Alkaline
20	Key Lock	All/Partial	All	All	All
21	LED	On/Off	On	On	On
22	Brightness	1 to 10	5	5	5
23	MachineID	Max 8 digit ASCII code	1	1	1
24	Preset Default		-	-	-
			Meeting Compressed	Music Compressed	Highest Quality Uncompressed

* Factory default of "Date Form" setting for Europe is D/M/Y.

1. Input

Audio input for recording are selected using the Input Menu. If Input of menu is Auto and External MIC is connected, Recording source is External MIC. When LINE jack is connected, Recording source is LINE audio. When the both connected at the same time the External MIC is active as priority.

1. From Stop, press and hold the **DISPLAY** button for 3 seconds.
2. Press the **VOL +** or **VOL –** button to select Preset Menu. Then press the **▶/||/ENTER** button to accept.
3. Press the **VOL +** or **VOL –** button to select Preset 1, 2 or 3. Then press the **▶/||/ENTER** button to accept the selected Preset.
4. Press the **VOL +** or **VOL –** button to select the Input item. Then press the **▶▶|** or **|◀◀** button to tab through the Input choices (Auto, INT MIC, MIC or LINE).
5. Press the **VOL +** or **VOL –** button to select other Menu choices. When changing the Preset is complete, press the **DISPLAY** button to store the changes, or press the **STOP/CANCEL** button to exit Menu mode without storing any changes.

2. Rec Format

The PMD620 can record in several compression algorithms. See explanation and chart below.

MP3-H	: MP3 compression with 192kbps (Mono:96kbps)
MP3-M	: MP3 compression with 128kbps (Mono:64kbps)
MP3-L	: MP3 compression with 64kbps (Mono:32kbps)
PCM-16	: Linear PCM with 16-bit depth
PCM-24	: Linear PCM with 24-bit depth

1. From Stop, press and hold the **DISPLAY** button for 3 seconds.
2. Press the **VOL +** or **VOL –** button to select Preset Menu. Then press the **▶/||/ENTER** button to accept.
3. Press the **VOL+** or **VOL–** button to select Preset 1, 2 or 3. Then press the **▶/||/ENTER** button to accept the selected Preset.
4. Press the **VOL +** or **VOL –** button to select the Rec Format item. Then press the **▶▶|** or **|◀◀** button to tab through the Rec Format choices (MP3-H, MP3-M, MP3-L, PCM-16 or PCM-24).
5. Press the **VOL +** or **VOL –** button to select other Menu choices. When changing the Preset is complete, press the **DISPLAY** button to store the changes, or press the **STOP/CANCEL** button to exit Menu mode without storing any changes.

3. Rec Channel

The Rec Channel menu choice allows you to select the channel of the audio file.

1. From Stop, press and hold the **DISPLAY** button for 3 seconds.
2. Press the **VOL +** or **VOL –** button to select Preset Menu. Then press the **▶/||/ENTER** button to accept.
3. Press the **VOL +** or **VOL –** button to select Preset 1, 2 or 3. Then press the **▶/||/ENTER** button to accept the selected Preset.
4. Press the **VOL +** or **VOL –** button to select the Rec Channel item. Then press the **▶▶|** or **|◀◀** button to tab through the Rec Channel choices (Stereo or Mono).
5. Press the **VOL +** or **VOL –** button to select other Menu choices. When changing the Preset is complete, press the **DISPLAY** button to store the changes, or press the **STOP/CANCEL** button to exit Menu mode without storing any changes.

4. Input Jack

The Input Jack menu choice allows you to select the type of the Input Jack for Stereo or Mono.

1. From Stop, press and hold the **DISPLAY** button for 3 seconds.
2. Press the **VOL +** or **VOL –** button to select Preset Menu. Then press the **▶/||/ENTER** button to accept.
3. Press the **VOL +** or **VOL –** button to select Preset 1, 2 or 3. Then press the **▶/||/ENTER** button to accept the selected Preset.
4. Press the **VOL +** or **VOL –** button to select the Input Jack item. Then press the **▶▶|** or **|◀◀** button to tab through the Input Jack choices (Stereo or Mono).
5. Press the **VOL +** or **VOL –** button to select other Menu choices. When changing the Preset is complete, press the **DISPLAY** button to store the changes, or press the **STOP/CANCEL** button to exit Menu mode without storing any changes.

5. Sample Rate

The Sample Rate menu choice allows you to select the sampling rate 44.1kHz or 48kHz.

1. From Stop, press and hold the **DISPLAY** button for 3 seconds.
2. Press the **VOL +** or **VOL –** button to select Preset Menu. Then press the **▶/||/ENTER** button to accept.
3. Press the **VOL +** or **VOL –** button to select Preset 1, 2 or 3. Then press the **▶/||/ENTER** button to accept the selected Preset.
4. Press the **VOL +** or **VOL –** button to select the Sample Rate item. Then press the **▶▶|** or **|◀◀** button to tab through the Sample Rate choices (44.1kHz or 48kHz).
5. Press the **VOL +** or **VOL –** button to select other Menu choices. When changing the Preset is complete, press the **DISPLAY** button to store the changes, or press the **STOP/CANCEL** button to exit Menu mode without storing any changes.

6. Manual Track

When the Manual Track (Manual Track incrementing) is On during recording, press the **REC** button to increment the audio file. A new audio file is created at that point.

1. From Stop, press and hold the **DISPLAY** button for 3 seconds.
2. Press the **VOL +** or **VOL –** button to select Preset Menu. Then press the **▶/||/ENTER** button to accept.
3. Press the **VOL +** or **VOL –** button to select Preset 1, 2 or 3. Then press the **▶/||/ENTER** button to accept the selected Preset.
4. Press the **VOL +** or **VOL –** button to select the Manual Track item. Then press the **▶▶|** or **|◀◀** button to tab through the Manual Track choices (On or Off).
5. Press the **VOL +** or **VOL –** button to select other Menu choices. When changing the Preset is complete, press the **DISPLAY** button to store the changes, or press the **STOP/CANCEL** button to exit Menu mode without storing any changes.

7. Auto Track

With the Auto Track (Automatic Track incrementing) on, a new file begins automatically at specified intervals of recording time. The Auto Track can be set to increment every 1, 5, 10, 15 or 30 minutes, or every 1, 2, 6, 8, 12 or 24 hours.

1. From Stop, press and hold the **DISPLAY** button for 3 seconds.
2. Press the **VOL +** or **VOL –** button to select Preset Menu. Then press the **▶/||/ENTER** button to accept.
3. Press the **VOL +** or **VOL –** button to select Preset 1, 2 or 3. Then press the **▶/||/ENTER** button to accept the selected Preset.
4. Press the **VOL +** or **VOL –** button to select the Auto Track item. Then press the **▶▶|** or **|◀◀** button to tab through the Auto Track choices (Off, 1, 5, 10, 15 or 30min, or 1, 2, 6, 8, 12 or 24hours).
5. Press the **VOL +** or **VOL –** button to select other Menu choices. When changing the Preset is complete, press the **DISPLAY** button to store the changes, or press the **STOP/CANCEL** button to exit Menu mode without storing any changes.

8. Silent Skip

The Silent Skip automatically pauses recording when there is a period of silence and resumes recording when sound resumes. This feature is often referred to as voice activated recording. Silent Skip looks for sound below a preset level for three seconds time. When that occurs, the PMD620 switches to record pause. When a signal above the preset level is input, recording resumes.

1. From Stop, press and hold the **DISPLAY** button for 3 seconds.
2. Press the **VOL +** or **VOL –** button to select Preset Menu. Then press the **▶/||/ENTER** button to accept.
3. Press the **VOL +** or **VOL –** button to select Preset 1, 2 or 3. Then press the **▶/||/ENTER** button to accept the selected Preset.
4. Press the **VOL +** or **VOL –** button to select the Silent Skip item. Then press the **▶▶|** or **|◀◀** button to tab through the Silent Skip choices (Off, –60dB, –54dB, –38dB or –20dB).
5. Press the **VOL +** or **VOL –** button to select other Menu choices. When changing the Preset is complete, press the **DISPLAY** button to store the changes, or press the **STOP/CANCEL** button to exit Menu mode without storing any changes.

9. Level Control

The Level Control allows you to select the type of input level control for recording.

1. From Stop, press and hold the **DISPLAY** button for 3 seconds.
2. Press the **VOL +** or **VOL –** button to select Preset Menu. Then press the **▶/||/ENTER** button to accept.
3. Press the **VOL +** or **VOL –** button to select Preset 1, 2 or 3. Then press the **▶/||/ENTER** button to accept the selected Preset.
4. Press the **VOL +** or **VOL –** button to select the “Level Cont.” item. Then press the **▶▶|** or **|◀◀** button to tab through the “Level Cont.” choices (Manual or ALC).
5. Press the **VOL +** or **VOL –** button to select other Menu choices. When changing the Preset is complete, press the **DISPLAY** button to store the changes, or press the **STOP/CANCEL** button to exit Menu mode without storing any changes.

10. Mic Attenuator

The Mic Attenuator let you select the direct use of microphone(s) that differ in sensitivity.

1. From Stop, press and hold the **DISPLAY** button for 3 seconds.
2. Press the **VOL +** or **VOL –** button to select Preset Menu. Then press the **▶/||/ENTER** button to accept.
3. Press the **VOL +** or **VOL –** button to select Preset 1, 2 or 3. Then press the **▶/||/ENTER** button to accept the selected Preset.
4. Press the **VOL +** or **VOL –** button to select the “Mic Atten.” item. Then press the **▶▶|** or **|◀◀** button to tab through the “Mic Atten.” choices (0dB, –12dB or –24dB).
5. Press the **VOL +** or **VOL –** button to select other Menu choices. When changing the Preset is complete, press the **DISPLAY** button to store the changes, or press the **STOP/CANCEL** button to exit Menu mode without storing any changes.

11. Low Cut

The bass region of the input audio is cut and the audio is recorded. Set to On to reduce noise, such as the sound of the wind when recording outdoors.

1. From Stop, press and hold the **DISPLAY** button for 3 seconds.
2. Press the **VOL +** or **VOL –** button to select Preset Menu. Then press the **▶/||/ENTER** button to accept.
3. Press the **VOL +** or **VOL –** button to select Preset 1, 2 or 3. Then press the **▶/||/ENTER** button to accept the selected Preset.
4. Press the **VOL +** or **VOL –** button to select the Low Cut item. Then press the **▶▶|** or **|◀◀** button to tab through the Low Cut choices (On or Off).
5. Press the **VOL +** or **VOL –** button to select other Menu choices. When changing the Preset is complete, press the **DISPLAY** button to store the changes, or press the **STOP/CANCEL** button to exit Menu mode without storing any changes.

12. Mic Power

The Mic Power allows you to switch the power on or off so supply to the external condenser microphone from the MIC jack of the PMD620.

1. From Stop, press and hold the **DISPLAY** button for 3 seconds.
2. Press the **VOL +** or **VOL –** button to select Preset Menu. Then press the **▶/||/ENTER** button to accept.
3. Press the **VOL +** or **VOL –** button to select Preset 1, 2 or 3. Then press the **▶/||/ENTER** button to accept the selected Preset.
4. Press the **VOL +** or **VOL –** button to select the Mic Power item. Then press the **▶▶|** or **|◀◀** button to tab through the Mic Power choices (On or Off).
5. Press the **VOL +** or **VOL –** button to select other Menu choices. When changing the Preset is complete, press the **DISPLAY** button to store the changes, or press the **STOP/CANCEL** button to exit Menu mode without storing any changes.

13. Level LED

When a sound is input during Record or Rec-Pause mode, the LEVEL LED(Green) turns on. A level to turn on is decided in presetting.

1. From Stop, press and hold the **DISPLAY** button for 3 seconds.
2. Press the **VOL +** or **VOL –** button to select Preset Menu. Then press the **▶/||/ENTER** button to accept.
3. Press the **VOL +** or **VOL –** button to select Preset 1, 2 or 3. Then press the **▶/||/ENTER** button to accept the selected Preset.
4. Press the **VOL +** or **VOL –** button to select the Level LED item. Then press the **▶▶|** or **|◀◀** button to tab through the Level LED choices (–54dB, –38dB, –20dB, –12dB or –6dB)
5. Press the **VOL +** or **VOL –** button to select other Menu choices. When changing the Preset is complete, press the **DISPLAY** button to store the changes, or press the **STOP/CANCEL** button to exit Menu mode without storing any changes.

14. Skip Back

How to change the Skip Back parameters.

1. From Stop, press and hold the **DISPLAY** button for 3 seconds.
2. Press the **VOL +** or **VOL –** button to select Preset Menu. Then press the **▶/||/ENTER** button to accept.
3. Press the **VOL +** or **VOL –** button to select Preset 1, 2 or 3. Then press the **▶/||/ENTER** button to accept the selected Preset.
4. Press the **VOL +** or **VOL –** button to select the Skip Back item. Then press the **▶▶|** or **|◀◀** button to tab through the Skip Back choices (1sec to 60sec)
5. Press the **VOL +** or **VOL –** button to select other Menu choices. When changing the Preset is complete, press the **DISPLAY** button to store the changes, or press the **STOP/CANCEL** button to exit Menu mode without storing any changes.

15. File Sort

The File Sort menu choice allows you to select the file order in the list by name (Alphabetical) or time (Time/Date).

1. From Stop, press and hold the **DISPLAY** button for 3 seconds.
2. Press the **VOL +** or **VOL –** button to select Preset Menu. Then press the **▶/||/ENTER** button to accept.
3. Press the **VOL +** or **VOL –** button to select Preset 1, 2 or 3. Then press the **▶/||/ENTER** button to accept the selected Preset.
4. Press the **VOL +** or **VOL –** button to select the File Sort item. Then press the **▶▶|** or **|◀◀** button to tab through the File Sort choices (Alphabetical or Time/Date).
5. Press the **VOL +** or **VOL –** button to select other Menu choices. When changing the Preset is complete, press the **DISPLAY** button to store the changes, or press the **STOP/CANCEL** button to exit Menu mode without storing any changes.

16. Date Form

The Date form is the date order month/day/year (M/D/Y) or day/month/year (D/M/Y).

1. From Stop, press and hold the **DISPLAY** button for 3 seconds.
2. Press the **VOL +** or **VOL –** button to select Preset Menu. Then press the **▶/||/ENTER** button to accept.
3. Press the **VOL +** or **VOL –** button to select Preset 1, 2 or 3. Then press the **▶/||/ENTER** button to accept the selected Preset.
4. Press the **VOL +** or **VOL –** button to select the Date Form item. Then press the **▶▶|** or **|◀◀** button to tab through the Date Form choices (M/D/Y or D/M/Y).
5. Press the **VOL +** or **VOL –** button to select other Menu choices. When changing the Preset is complete, press the **DISPLAY** button to store the changes, or press the **STOP/CANCEL** button to exit Menu mode without storing any changes.

17. Font Size

You can increase the font size of the text on the file list screen and preset setting screen.

1. From Stop, press and hold the **DISPLAY** button for 3 seconds.
2. Press the **VOL +** or **VOL –** button to select Preset Menu. Then press the **▶/||/ENTER** button to accept.
3. Press the **VOL +** or **VOL –** button to select Preset 1, 2 or 3. Then press the **▶/||/ENTER** button to accept the selected Preset.
4. Press the **VOL +** or **VOL –** button to select the Font Size item. Then press the **▶▶|** or **|◀◀** button to tab through the Font Size choices (Large or Small).
5. Press the **VOL +** or **VOL –** button to select other Menu choices. When changing the Preset is complete, press the **DISPLAY** button to store the changes, or press the **STOP/CANCEL** button to exit Menu mode without storing any changes.

18. Auto Power Off

If the PMD620 is not operated for 15 minutes during Stop or Play-Pause mode, the power can be automatically shut off to conserve battery life.

1. From Stop, press and hold the **DISPLAY** button for 3 seconds.
2. Press the **VOL +** or **VOL –** button to select Preset Menu. Then press the **▶/||/ENTER** button to accept.
3. Press the **VOL +** or **VOL –** button to select Preset 1, 2 or 3. Then press the **▶/||/ENTER** button to accept the selected Preset.
4. Press the **VOL +** or **VOL –** button to select the Auto Power Off item. Then press the **▶▶|** or **|◀◀** button to tab through the Auto Power Off choices (On or Off).
5. Press the **VOL +** or **VOL –** button to select other Menu choices. When changing the Preset is complete, press the **DISPLAY** button to store the changes, or press the **STOP/CANCEL** button to exit Menu mode without storing any changes.

19. Battery

The PMD620 operates on 2 standard AA size Alkaline, or Ni-MH batteries.

1. From Stop, press and hold the **DISPLAY** button for 3 seconds.
2. Press the **VOL +** or **VOL –** button to select Preset Menu. Then press the **▶/||/ENTER** button to accept.
3. Press the **VOL +** or **VOL –** button to select Preset 1, 2 or 3. Then press the **▶/||/ENTER** button to accept the selected Preset.
4. Press the **VOL +** or **VOL –** button to select the Battery item. Then press the **▶▶|** or **|◀◀** button to tab through the Battery choices (Alkaline or Ni-MH).
5. Press the **VOL +** or **VOL –** button to select other Menu choices. When changing the Preset is complete, press the **DISPLAY** button to store the changes, or press the **STOP/CANCEL** button to exit Menu mode without storing any changes.

20. Key Lock

The key lock secures the PMD620 in the state it is in during Record, Playback or Stop. If this setting is All, all buttons on PMD620 are invalid. If this setting is Partial, the **REC**, **REC PAUSE** and **STOP/CANCEL** buttons are accepted.

1. From Stop, press and hold the **DISPLAY** button for 3 seconds.
2. Press the **VOL +** or **VOL –** button to select Preset Menu. Then press the **▶/||/ENTER** button to accept.
3. Press the **VOL +** or **VOL –** button to select Preset 1, 2 or 3. Then press the **▶/||/ENTER** button to accept the selected Preset.
4. Press the **VOL +** or **VOL –** button to select the Key Lock item. Then press the **▶▶|** or **|◀◀** button to tab through the Key Lock choices (All or Partial).
5. Press the **VOL +** or **VOL –** button to select other Menu choices. When changing the Preset is complete, press the **DISPLAY** button to store the changes, or press the **STOP/CANCEL** button to exit Menu mode without storing any changes.

21. LED

The LED menu choice allows you to turn off the light of all LEDs.

1. From Stop, press and hold the **DISPLAY** button for 3 seconds.
2. Press the **VOL +** or **VOL –** button to select Preset Menu. Then press the **▶/||/ENTER** button to accept.
3. Press the **VOL +** or **VOL –** button to select Preset 1, 2 or 3. Then press the **▶/||/ENTER** button to accept the selected Preset.
4. Press the **VOL +** or **VOL –** button to select the LED item. Then press the **▶▶|** or **|◀◀** button to tab through the LED choices (On or Off).
5. Press the **VOL +** or **VOL –** button to select other Menu choices. When changing the Preset is complete, press the **DISPLAY** button to store the changes, or press the **STOP/CANCEL** button to exit Menu mode without storing any changes.

22. Brightness

The Brightness menu choice allows you to adjust the brightness of the OLED (Organic Light-Emitting Diode) display on the PMD620.

1. From Stop, press and hold the **DISPLAY** button for 3 seconds.
2. Press the **VOL +** or **VOL –** button to select Preset Menu. Then press the **▶/||/ENTER** button to accept.
3. Press the **VOL +** or **VOL –** button to select Preset 1, 2 or 3. Then press the **▶/||/ENTER** button to accept the selected Preset.
4. Press the **VOL +** or **VOL –** button to select the Brightness item. Then press the **▶▶|** or **|◀◀** button to tab through the Brightness choices (1, 2, 3, 4, 5, 6, 7, 8, 9 or 10).
5. Press the **VOL +** or **VOL –** button to select other Menu choices. When changing the Preset is complete, press the **DISPLAY** button to store the changes, or press the **STOP/CANCEL** button to exit Menu mode without storing any changes.

23. Machine ID

An audio file has Machine ID information. This information is included in the file name.

For example, if the Machine ID is "aaaaa", the first file is numbered "aaaaa001.wav" or "aaaaa001.mp3".

The Machine ID setting applies to all three presets.

1. From Stop, press and hold the **DISPLAY** button for 3 seconds.
2. Press the **VOL +** or **VOL –** button to select Preset Menu. Then press the **▶/||/ENTER** button to accept.
3. Press the **VOL +** or **VOL –** button to select Preset 1, 2 or 3. Then press the **▶/||/ENTER** button to accept the selected Preset.
4. Press the **VOL +** or **VOL –** button to select the "MachineID" item. Then press the **▶/||/ENTER** button to rename.
5. Rename the Mechinae ID.
Text can be inserted and deleted. Press the **◀◀** or **▶▶** button to move the cursor to the place you wish to insert text into or delete text from.

To insert text

Press the **VOL +** or **VOL –** button to select the character you want to insert. When the character that you wish to insert is displayed, press the **▶/||/ENTER** button to enter the character. The selected character for insertion is highlighted.

To delete text

Press the **SKIP BACK** button to delete the selected character.

6. Press the **▶/||/ENTER** button to enter the changes. When changing the Preset is complete, press the **DISPLAY** button to store the changes, or press the **STOP/CANCEL** button to exit Menu mode without storing any changes.

Notes:

- If Last letter of the Machine ID is Space(SP) character, the changed ID do not include the last letter.
- If number of letter is more than 8, last letter is deleted when a new letter is added.
- The characters which you can insert are A a B b C c D d E e F f G g H h I i J j K k L l M m N n O o P p Q q R r S s T t U u V v W w X x Y y Z z (Space) ! "# \$ % & ' () + , - . : ; = @] ^ _ ` { } ~ 0 1 2 3 4 5 6 7 8 9.

24. Default

Returns the settings of the selected preset number to default. See page 44 for a table of menu defaults.

1. From Stop, press and hold the **DISPLAY** button for 3 seconds.
2. Press the **VOL +** or **VOL –** button to select Preset Menu. Then press the **▶/||/ENTER** button to accept.
3. Press the **VOL +** or **VOL –** button to select Preset 1, 2 or 3. Then press the **▶/||/ENTER** button to accept the selected Preset.
4. Press the **VOL +** or **VOL –** button to select the Preset Default item. Then press the **▶/||/ENTER** button to initialize.
5. While “Default?” message is displayed, select “Yes” and then press the **▶/||/ENTER** button, then preset value returns to default and to starts writing on non-volatile memory.

Troubleshooting

Should problems occur, it is often unnecessary to consult your dealer or technical service department. On the basis of the following checks, you may be able to rectify a number of conditions yourself without difficulty. If the condition cannot be remedied after the following check, please consult your dealer.

The PMD620 does not turn on.

- Install fresh batteries.
- Check AC adapter connections.

The PMD620 turns on then turns itself off.

- Install fresh batteries.

The PMD620 seems to record, but there is no sound on playback.

- Check input settings.
(For example, if LINE input is selected and no input is connected to the LINE jack, the PMD620 will record silence. The PMD620 will not playback.)

There is no audio playback through headphones or internal speaker.

- Check VOL+/- control setting.
- Check a different audio file or the card.

The PMD620 will not record.

- Check that the maximum of 999 files have not been recorded.
- Check that the PMD620 acknowledges the card.

No signal from microphone input.

- Check input selection.
- Check REC LEVEL control settings.
- Check if microphone(s) require(s) Phantom power.

There is excessive noise on the PMD620.

- Check cable connections and/or replace cable.
- Check for proper gain levels.

Playback on a PC results in poor sound.

- Check quality of PC sound card and program.
- Check frequency conversion program.*

* The PMD620 records audio files with a sampling frequency of 48kHz. Some PC programs convert the files to 44.1kHz (using a sample rate converter). Only high quality sample rate converters should be used.

PC cannot read files

- Check the capability of the PC program. Some playback and editing programs do not support MP3 or Broadcast Wave (.wav) formats.

If the PMD620 exhibits erratic behavior, the microprocessor can be reset by powering off, disconnecting AC power and removing batteries.

Care and Maintenance

Use a soft cloth slightly moistened with mild detergent solution. Media cards that are heavily used should be occasionally reformatted to avoid audio problems due to fragmentation.

Error Message

Details of error processing

Display	Description
No Card	Card cannot be found
Unformat	Format other than FAT16/32, or card format error
Full Card	Memory is not enough
Full 999	Files are more than 999
No File	No file found
Key Locked	Operation during Key Lock
Card Locked	Prohibition of writing into the card
ALC	REC LEVEL operation during ALC On
VBR	FWD or RWD of VBR file
Can not...	Command is invalid
Need DC IN	No DC input
Low Battery (flashing highlighted)	Remaining battery is below set value
Low Battery	automatic power down in low battery level last time.
No PresetFile	No preset setting file is found
ErrPresetFile	File contents of preset setting has errors
ErrUpdateFile	Version up file or file system does not function normally
Door Open	CF door is open
Err Format	Error in file format of MP3 or PCM
Exist Title	Same file title is found
Limit 80m	Over 80 minutes in copy segment process
Long Title	File title exceeds 64 Bytes
Err Card	Error is found in the card
Err RTC	Error is found in RTC
Err SRAM	Error is found in SRAM
Err FlashROM	Error is found in Flash ROM

Specifications

Digital audio system

System.....	Solid State Recorder
Usable media	SD/SDHC cards
Recording format	
MP3.....	MPEG1 LayerIII Compression
WAV	16/24 bit linear PCM
Recording MP3 bitrate	
Stereo	192/128/64 kbps
mono.....	96/64/32 kbps
Sample rate	44.1/48 kHz
Number of channels.....	2 (Stereo)/1 (Mono)
Frequency response	20 Hz (±0.5 dB) to 16 kHz (±0.5 dB)
S/Noise Ratio IEC-A weighted	
MIC	65 dB
LINE	80 dB
Total harmonic distortion at 0 VU	
MIC	0.1%
LINE	0.015%
Dynamic range.....	90 dB

Inputs

External MIC	
Type	1/8" stereo jack
Input sensitivity	12 mVrms/30 kohms
LINE	
Type	1/8" stereo jack
Input sensitivity	500 mVrms/20 kohms

Outputs

LINE	
Type	1/8" stereo jack
Standard level.....	1.0 V/10 kohms
Headphone	
Type	1/8" stereo jack
Standard level.....	16 mW/16 ohms
Speaker	
Standard level.....	150 mW/8 ohms

General

Power consumption	
Recording/Playback	4.0 W (DC)
Battery life (Alkaline).....	4 hours (typical)
Phantom power.....	5V, 1mA
Environmental conditions	
Operational temperature	0 to 40°C (32 to 104°F)
Operational humidity	25 to 85% (no condensation)
Storage temperature	-20 to 60°C (-4 to 140°F)
Dimensions	
Width.....	102 mm (4")
Height	62 mm (2.5")
Depth	25 mm (1")
Weight.....	0.11 kg (0.3 lbs.)

Included accessories

- Audio cable
- USB cable
- AC adapter
- User guide
- CD-ROM
- Handy Strap
- Customer Registration Document (USA only)
- Tripod Adapter
- SD Card

- Specifications are subject to change without prior notice.

Limited Warranty

Your Marantz Professional product is warranted against manufacturer defects in material and workmanship for a period of one year parts and labor.

Except as specified below, this warranty covers defects in material and workmanship. The following are not covered under warranty:

1. Damage, deterioration, malfunction or failure to meet performance specifications resulting from:
 - a) Accidents, acts of nature, misuse, abuse, neglect or **unauthorized product modification**.
 - b) Improper installation, removal or maintenance, or failure to **follow supplied instructions**.
 - c) Repair or attempted repair by a non-Marantz authorized **agent**.
 - d) Any shipment (claims must be presented to the carrier).
 - e) Any cause other than a defect of manufacturing.
2. Cleaning, check-ups with no fault found or changes incurred for installation, removal or reinstallation of the product.
3. Any serialized product on which the serial number has been defaced, modified or removed.
4. Batteries and battery chargers.
5. Accessories, including but not limited to: cables, mounting hardware and brackets, cleaning accessories, power cords and adapters, and carry cases.

Non-transferable warranty

This Warranty may be enforced only by the original purchaser.

What We Will Pay For

We will pay for all labor and material expenses for items covered by the warranty.

How You Can Get Service (Americas only)

1. If your unit needs service in the USA, contact our service referral at the appropriate telephone number indicated below. We will advise you of the name and location of one or more authorized service centers from which service may be obtained. Please do not return the unit directly to us.
2. You must pay any shipping charges if it is necessary to ship the product for service. If the necessary repairs are covered by the warranty, we will pay return shipping charges to your location anywhere in the United States or its territories.
3. Whenever warranty service is required, you must present the original dated sales receipt or other proof of date purchased.

Limitation of Implied Warranties

All implied warranties, including warranties of merchantability and fitness for a particular purpose, are limited in duration to the length of this warranty.

Exclusion of Damages (Americas only)

Liability for any defective product is limited to repair or replacement of the product at manufacturer's option. Manufacturer shall not be liable for damage to other products caused by any defects in Marantz products, damages based on inconvenience or loss of use of the product, or any other damages, whether incidental, consequential, or otherwise.

Some States do not allow limitations on how long an implied warranty lasts and/or do not allow the exclusion or limitation of incidental or consequential damages, so the above limitations and exclusions may not apply to you.

How State Law Relates to the Warranty (Americas only)

This warranty gives you specific legal rights, and you may have other rights which may vary from State to State.

Marantz Professional Service Number (Americas only):

Marantz Professional Factory Service (630) 741-0330, toll free within the US (866) 405-2154.

Products purchased outside of the United States, its possessions or territories.

This warranty is enforceable only in the United States and its possessions or territories.

Marantz Professional products Sales Office Site:

For inquiries or information on repair service of Marantz Professional Products, please contact our Sales Office or Tech Support Centre near you which are listed in D&M Professional website below.

AMERICA

D&M Professional America <http://www.d-mpro.com>
Service number : 866-405-2154 (Toll Free)

EUROPE

D&M Professional Europe <http://www.d-mpro.eu.com>

ASIA/OTHERS

D&M Professional Asia <http://www.d-mproasia.com>

D&M Holdings Inc.
PROFESSIONAL BUSINESS COMPANY



2007/09 00M10CS851010 ecmf-g