

Specifications

SMART Board® 6075 interactive flat panel with iQ

Model SPNL-6275

Overview

The SMART Board® 6075 interactive flat panel with iQ is the hub of your classroom. iQ technology connects devices, lesson content and pedagogically relevant software to create a cohesive educational experience. PC-free embedded computing provides one-touch access to a diverse suite of SMART applications—Notebook lessons, amp workspaces, lab gamification activities and whiteboard—and collaborative tools, such as wireless screen sharing and a web browser. There’s no need for wires, cables or manual software and firmware updates.



The 75" 4K ultra-high-definition LED display provides optimal image clarity and wide viewing angles. With the Pen ID™ feature, you can assign different appearances to the two pens and write or draw over any application in digital ink.

Object awareness™ allows you to perform mouse functions with your finger, write in digital ink with the pen, and erase with your palm or eraser—all without switching tools or modes. You can use a variety of gestures in applications, and two users can write or draw at the same time.

See education.smarttech.com for more information about this product.

Dimensions and weights¹

Dimensions

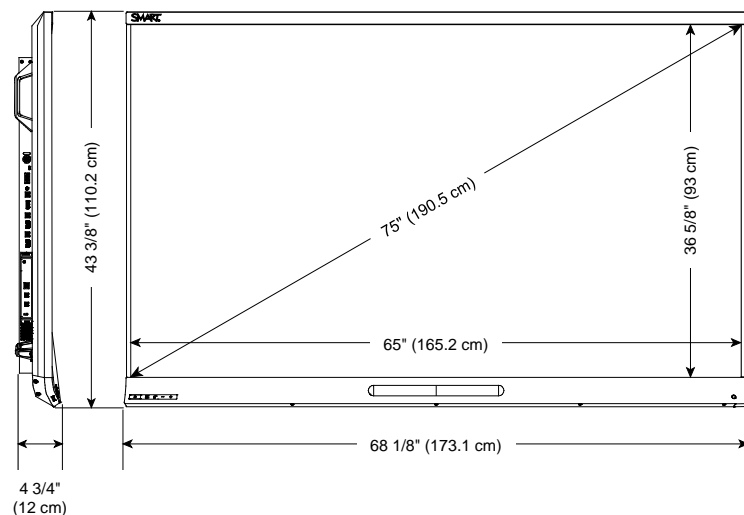

Weight

185 lb. (84 kg)

Shipping dimensions (including pallet)

75 3/8" × 54 3/8" × 14"

(191.6 cm × 138 cm × 35.5 cm)

Shipping weight

238 lb. (108 kg)



As an ENERGY STAR® certified signage display, the SMART Board 6075 interactive flat panel with iQ meets strict energy efficiency guidelines set by the U.S. Environmental Protection Agency and Department of Energy.

¹All dimensions ± 1/8" (0.3 cm). All weights ± 2 lb. (0.9 kg).

Hardware

Interaction

Touch technology	DViT® (Digital Vision Touch) technology
Multitouch capabilities	8 touches ²
Object awareness	Behavior adjusts automatically to the tool or object you're using, whether it's a pen, finger, eraser or palm.
Pen ID	Two people can write independently and simultaneously, using different colored ink.

Display

Type	LED
Aspect ratio	16:9
Optimal resolution	3840 × 2160 at 30 Hz (HDMI®) or 60 Hz (DisplayPort)
Horizontal frequency (typical)	135 kHz
Vertical frequency (typical)	60 Hz
Contrast ratio (typical)	5000:1
Brightness (maximum)	360 cd/m ²
Pixel dimensions	0.429 mm × 0.429 mm
Gamut	72% of NTSC
Viewing angle	178°
Response time (typical)	8 ms

Presence detection Presence detection sensor on the bottom frame

Audio 10 W integrated speakers (×2)

Noise level <35 dBA

Included cables and accessories
 iQ appliance
 8' (2.4 m) country-specific power cable
 16' 5" (5 m) USB cable
 Pen (×2)

iQ appliance

Wireless technology	Bluetooth® 4.0 dual mode (backwards compatible with Bluetooth 2.1 + EDR)
Capture options	Establish a Bluetooth wireless connection with a supported mobile device (see below) by scanning the interactive display's unique QR code

²Requires SMART Product Drivers to be installed. Some applications might not support 8 touches.

Supported languages	French German Italian Japanese Korean Norwegian Simplified Chinese Spanish Swedish Traditional Chinese
Mounting holes	For a standard VESA® 600 mm × 400 mm mounting plate Lower mounting holes 13 3/4" (35 cm) from the bottom of the interactive flat panel
Mounting bracket depth	Minimum depth of 1 5/8" (4.2 cm) for all components on the back of the interactive display to clear the wall

Connectors

Side	<p>Connector panel</p> <p>OPS slot (for the iQ appliance) HDMI1 input connectors HDMI in USB Type-B HDMI2 input connectors HDMI in USB Type-B DisplayPort input connectors DisplayPort in USB-Type-B Stereo 3.5 mm out RS-232 in</p>	<p>iQ appliance</p> <p>USB 3.0 Type-A (×2) USB 2.0 Type-B³ OPS/HDMI input connectors HDMI in USB Type-B HDCP encrypted HDMI 1.4 out RJ45</p>
Bottom	USB 2.0 Type-A	
Back	AC power inlet	

Installation requirements

Interactive flat panel	See the <i>SMART Board 6000 and 6000 Pro series interactive displays installation and maintenance guide</i> (smarttech.com/kb/171167)
SMART Notebook Player mobile app	iOS 10 or later operating system software

³For service use only

SMART kapp® app

Apple devices	iOS 9 or later operating system software 50 MB of storage iPhone 4S or later Third-generation iPad or later First-generation iPad mini or later Fifth-generation iPod touch or later
Android™ devices	Android 4.4.4 (KitKat) or later operating system 50 MB of storage (internal or SD card) 1024 MB of RAM 720p or better screen resolution Bluetooth 2.1 + EDR 3 megapixel or better rear-facing camera (recommended)

SMART kapp viewer

Mobile	Safari for iOS 9 or later operating system software Chrome™ for Android 39.0.2171.93 or later
Desktop	Internet Explorer® 10 or later Chrome 39.0.2171.95 or later Firefox® 34.0.5 or later Safari 8.0 or later

Room computers and guest laptops

General requirements	See the SMART Notebook software release notes
4K UHD	Graphics card that can support 3840 × 2160 resolution at 30 Hz and that has 1 GB DDR 5 memory See Minimum requirements for Ultra High Definition or 4K on your interactive flat panel

Mini-computers

General requirements	See the SMART Notebook software release notes
Dimensions	Smaller than 10" × 10" × 2" (25.4 cm × 25.4 cm × 5.1 cm)
Weight	Less than 10 lb. (4.5 kg)
Mounting	VESA 75 mm × 75 mm or 100 mm × 100 mm mounting pattern

Cable requirements**HDMI**

Maximum length: 23' (7 m)

 **NOTES**

- Use only certified HDMI cables that have been tested to support the performance standard you require.
- The performance of cables longer than 23' (7 m) is highly dependent on the cable's quality.

DisplayPortDisplayPort 1.2 compliant or better
Maximum length: 23' (7 m)

USB	Maximum length: 16' (5 m)
Important	Using cables that exceed these maximum lengths can produce unexpected results, such as degraded picture quality or USB connectivity. Refer to <i>SMART installation standards</i> (smarttech.com/kb/171035) for comprehensive information about cables and extensions for SMART hardware products.

Storage and operating requirements

Power requirements	100V to 240V AC, 50 Hz to 60 Hz
Interactive flat panel and iQ appliance power consumption at 77°F (25°C)	
Standby mode	19 W
Normal operating	190 W
Maximum operating	315 W
Standalone interactive flat panel power consumption at 77°F (25°C)	
Standby mode	<2 W
Normal operating (out-of-box)	<131 W
Operating temperature	41–95°F (5–35°C)
Storage temperature	-4–140°F (-20–60°C)
Humidity	5–80% relative humidity, non-condensing

Certification and compliance

Regulatory certification	UL (U.S./Canada), FCC, IC, EMC, LV, VCCI, PSE
Environmental compliance	
European Union	REACH, RoHS, WEEE and Packaging
U.S.	Packaging and Conflict Minerals

Purchasing information

Order number	
SPNL-6275	SMART Board 6075 interactive flat panel with iQ and SMART Learning Suite
Optional accessories	
WM-SBID-501	Fixed wall mount for SMART Board interactive displays
Other	See smarttech.com/accessories
Warranty	Three-year limited equipment warranty

SMART BOARD 6075 INTERACTIVE FLAT PANEL WITH IQ – MODEL SPNL-6275

Extended warranty

EWY1-SPNL-6275 One-year warranty extension

EWY2-SPNL-6275 Two-year warranty extension

smarttech.com/support
smarttech.com/contactsupport

© 2017 SMART Technologies ULC. All rights reserved. SMART Board, SMART kapp, DVIT, Pen ID, Object Awareness, smarttech, the SMART logo and all SMART taglines are trademarks or registered trademarks of SMART Technologies ULC in the U.S. and/or other countries. iPhone, iPad, iPod touch and Safari are trademarks of Apple Inc., registered in the U.S. and other countries. Google Play, Android and Chrome are trademarks of Google Inc. The Bluetooth word mark is owned by the Bluetooth SIG, Inc. and any use of such marks by SMART Technologies ULC is under license. All other third-party product and company names may be trademarks of their respective owners. This product and/or use thereof is covered by one or more of the following U.S. patents: www.smarttech.com/patents. Contents are subject to change without notice. 10/2017.