



# LS1-UC20E Pendant Sphere Loudspeaker



- ▶ **Superb speech and music reproduction**
- ▶ **Wide sound spread**
- ▶ **Ease of installation**
- ▶ **Modern unobtrusive styling**
- ▶ **Tough, impact-resistant enclosure**
- ▶ **5 m connection cable**
- ▶ **Provision for optional safety cord**
- ▶ **Water and dust protected to IP 65**
- ▶ **BS 5839-8 compliant**

Sound spheres are pendant sound projectors designed to be suspended from the ceiling by their connecting cables. Their excellent sound spread makes them ideal for use in buildings with high ceilings, such as hypermarkets and superstores.

The LS1-UC20E is a powerful 20 W pendant sphere loudspeaker, intended for high quality speech and music reproduction. The state-of-the-art design is matched to both modern and traditional style environments. The loudspeaker is suitable for use in voice evacuation systems.

## Functions

### Voice Alarm Loudspeaker

Voice alarm loudspeakers are specifically designed for use in buildings where performance of systems for verbal communication announcements is governed by regulations. The LS1-UC20E is designed for use in voice alarm systems and is compliant with British standard BS 5839-8.

The loudspeaker has built-in protection to ensure that, in the event of a fire, damage to the loudspeaker does not result in failure of the circuit to which it is connected. In this way, system integrity is maintained, ensuring loudspeakers in other areas can still be used to inform people of the situation. The loudspeaker is supplied with a ceramic terminal block and thermal fuse.

### Superb Sound Quality

The use of a high quality driver in combination with advanced filtering, have resulted in a very natural sound reproduction with excellent bass response.

## Certifications and Approvals

All Bosch loudspeakers are designed to withstand operating at their rated power for 100 hours in accordance with IEC 268-5 Power Handling Capacity (PHC) standards. Bosch has also developed the Simulated Acoustical Feedback Exposure (SAFE) test to demonstrate that they can withstand two times their rated power for short durations. This ensures extra reliability under extreme conditions, leading to higher customer satisfaction, longer operating life, and much less chance of failure or performance deterioration.

### Safety Aspects

In common with all Bosch products, care is taken to meet high safety standards. All ABS parts are self-extinguishing (according to UL 94 V0) This sound projector complies with the relevant safety and installation regulations of EN 60065.

Region	Certification	
Europe	CE	Declaration of Conformity
Water-and dust protected	acc. to IEC 60529, IP 65	

**Installation/Configuration Notes**

**Mounting**

The loudspeaker is suspended from the ceiling via its 5 m, 4-core connecting cable, which is easy to shorten for the desired height. For optional safety, a steel safety cord can be attached.

**Power Setting**

The loudspeaker is supplied with a 5 m color-coded, four-core connecting cable with each color connected to a different primary tap on the 100 V matching transformer. This allows nominal full-power, half-power or quarter-power radiation to be selected (in 3 dB steps).

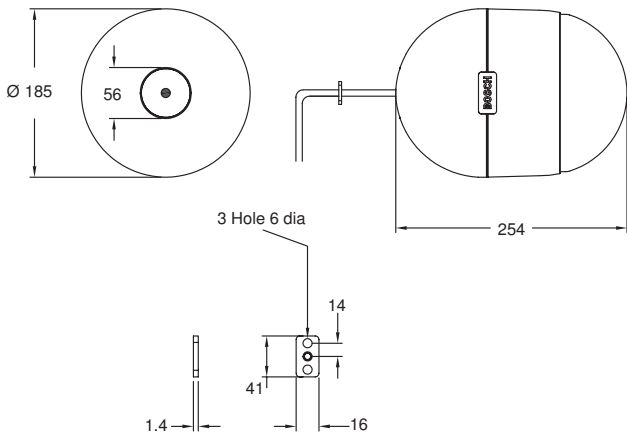

Dimensions in mm

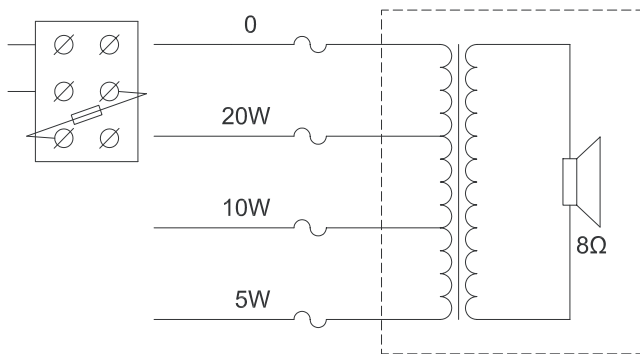

Circuit diagram

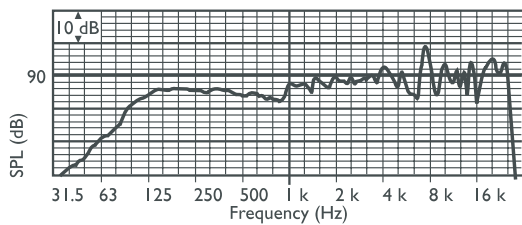

Frequency response

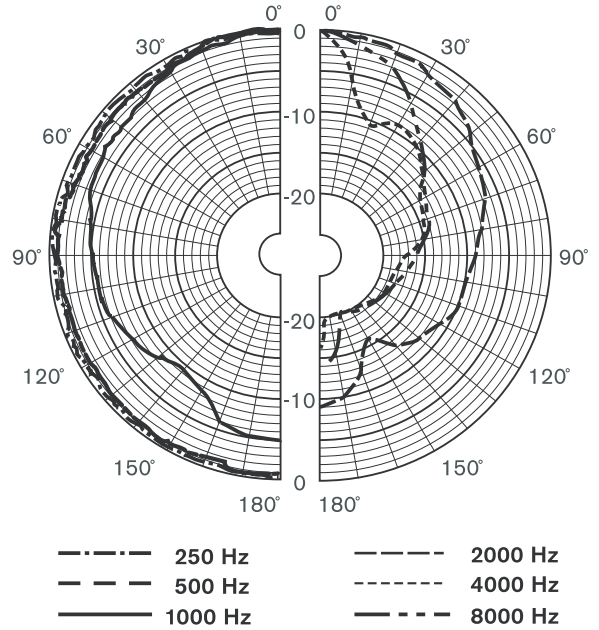

Polar diagram (measured with pink noise)

**Parts Included**

Quantity	Components
1	LS1-UC20E Pendant Sphere Loudspeaker
1	Cable clamp

**Technical Specifications**

**Electrical\***

Maximum power	30 W
Rated power	20 / 10 / 5 W
Sound pressure level at 20 W / 1 W (1kHz, 1 m)	99 dB / 86 dB (SPL)
Opening angle at 1 kHz / 4 kHz (-6 dB)	220° / 65°
Effective frequency range (-10 dB)	80 Hz to 20 kHz
Rated voltage	100 V
Rated impedance	500 ohm
Connector	3-pole screw terminal

\* Technical performance data acc. to IEC 60268-5

**Mechanical**

Dimensions (D x L)	185 x 254 mm (7.3 x 10 in)
Weight	3 kg (6.6 lb)
Color	White (RAL 9010)
Material	ABS

**Environmental**

Operating temperature	-25 °C to +55 °C (-13 °F to +131 °F)
Storage temperature	-40 °C to +70 °C (-40 °F to +158 °F)
Relative humidity	<95%

**Ordering Information**

**LS1-UC20E Pendant Sphere Loudspeaker**      **LS1-UC20E**  
20 W, white ABS

**Americas:**  
Bosch Security Systems, Inc.  
130 Perinton Parkway  
Fairport, New York, 14450, USA  
Phone: +1 800 289 0096  
Fax: +1 585 223 9180  
security.sales@us.bosch.com  
www.boschsecurity.us

**Europe, Middle East, Africa:**  
Bosch Security Systems B.V.  
P.O. Box 80002  
5600 JB Eindhoven, The Netherlands  
Phone: +31 40 2577 284  
Fax: +31 40 2577 330  
emea.securitysystems@bosch.com  
www.boschsecurity.com

**Asia-Pacific:**  
Bosch Security Systems Pte Ltd  
38C Jalan Pemimpin  
Singapore 577180  
Phone: +65 6319 3450  
Fax: +65 6319 3499  
apr.securitysystems@bosch.com  
www.boschsecurity.com

**Represented by**