

# User Manual

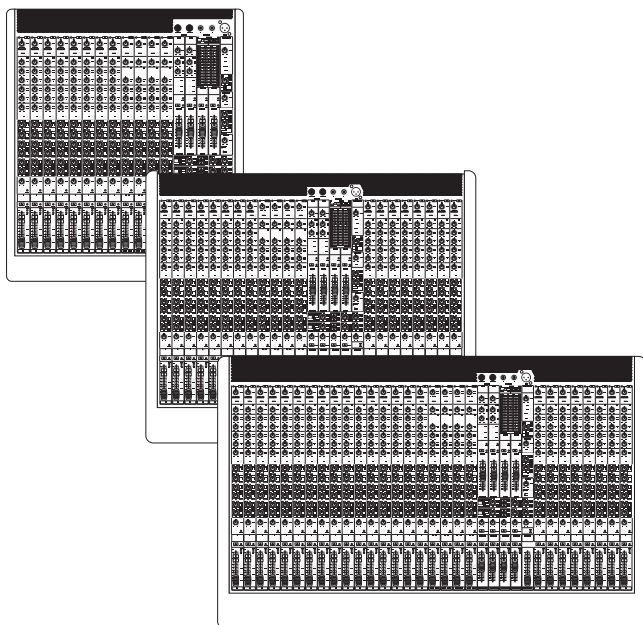

# XENYX XL1600/XL2400/XL3200

## Premium 16/24/32-Input 4-Bus Live Mixer with XENYX Mic Preamps and British EQs

## Thank you

Congratulations! By purchasing one of the XENYX mixing consoles you have acquired a state-of-the-art audio mixer that sets new standards. Right from the very start it has been our goal to design a revolutionary unit that can be used for a great variety of applications. And indeed, this overwhelming mixing console gives you plenty of functionality and a broad range of connection and expansion options.

## Table of Contents

Thank you .....	1
Important Safety Instructions .....	2
1. Introduction .....	3
2. Quick start .....	4
3. Installation.....	6
4. Connectors .....	8
5. Control elements .....	10
6. Modifications .....	17
7. Specifications .....	18
Limited Warranty.....	21
Legal Disclaimer .....	22

This manual is available in English, German, French, Spanish, Italian, Russian, Polish, Dutch, Finnish, Swedish, Danish, Portuguese, Greek, Japanese and Chinese. There may also be more current versions of this document. Download them by going to the appropriate product page at:

**[www.behringer.com](http://www.behringer.com)**

A50-00000-03078



## Important Safety Instructions



Terminals marked with this symbol carry electrical current of sufficient magnitude to constitute risk of electric shock. Use only high-quality commercially-available speaker cables with ¼" TS plugs pre-installed. All other installation or modification should be performed only by qualified personnel.



This symbol, wherever it appears, alerts you to the presence of uninsulated dangerous voltage inside the enclosure - voltage that may be sufficient to constitute a risk of shock.



This symbol, wherever it appears, alerts you to important operating and maintenance instructions in the accompanying literature. Please read the manual.



### Caution

To reduce the risk of electric shock, do not remove the top cover (or the rear section). No user serviceable parts inside. Refer servicing to qualified personnel.



### Caution

To reduce the risk of fire or electric shock, do not expose this appliance to rain and moisture. The apparatus shall not be exposed to dripping or splashing liquids and no objects filled with liquids, such as vases, shall be placed on the apparatus.



### Caution

These service instructions are for use by qualified service personnel only. To reduce the risk of electric shock do not perform any servicing other than that contained in the operation instructions. Repairs have to be performed by qualified service personnel.

- 1 Read these instructions.
- 2 Keep these instructions.
- 3 Heed all warnings.
- 4 Follow all instructions.
- 5 Do not use this apparatus near water.

- 6 Clean only with dry cloth.
- 7 Do not block any ventilation openings. Install in accordance with the manufacturer's instructions.
- 8 Do not install near any heat sources such as radiators, heat registers, stoves, or other apparatus (including amplifiers) that produce heat.
- 9 Do not defeat the safety purpose of the polarized or grounding-type plug. A polarized plug has two blades with one wider than the other. A grounding-type plug has two blades and a third grounding prong. The wide blade or the third prong are provided for your safety. If the provided plug does not fit into your outlet, consult an electrician for replacement of the obsolete outlet.
- 10 Protect the power cord from being walked on or pinched particularly at plugs, convenience receptacles, and the point where they exit from the apparatus.
- 11 Use only attachments/accessories specified by the manufacturer.
- 12 Use only with the cart, stand, tripod, bracket, or table specified by the manufacturer, or sold with the apparatus. When a cart is used, use caution when moving the cart/apparatus combination to avoid injury from tip-over.
- 13 Unplug this apparatus during lightning storms or when unused for long periods of time.
- 14 Refer all servicing to qualified service personnel. Servicing is required when the apparatus has been damaged in any way, such as power supply cord or plug is damaged, liquid has been spilled or objects have fallen into the apparatus, the apparatus has been exposed to rain or moisture, does not operate normally, or has been dropped.
- 15 The apparatus shall be connected to a MAINS socket outlet with a protective earthing connection.
- 16 Where the MAINS plug or an appliance coupler is used as the disconnect device, the disconnect device shall remain readily operable.



## 1. Introduction

BEHRINGER is a company with its roots in professional recording studio technology. For many years now we have been successful in developing products for studio and live use. These include microphones and studio gear of all kinds (compressors, enhancers, noise gates, tube processors, headphone amplifiers, digital effects, DI boxes, etc.), monitor and PA speakers as well as professional live and recording mixers. Our entire technical know-how has gone into your XENYX mixing console.

### 1.1 Before you get started

#### 1.1.1 Shipment

Your XENYX was carefully packed at the factory, and the packaging was designed to protect the unit from damage caused by rough handling. Nevertheless, we recommend that you carefully examine the packaging and its contents for any signs of physical damage that may have occurred during transit.

- ◆ If the unit is damaged, please do NOT return it to us; instead, notify your dealer and the shipping company immediately, otherwise claims for damage or replacement may not be granted.
- ◆ We recommend using a case to ensure optimal protection of the device.
- ◆ Please always use the original packaging to avoid damage due to storage or shipping.
- ◆ Never let unsupervised children play with the XENYX or with its packaging.
- ◆ Recycle whenever possible.

#### 1.1.2 Initial operation

Ensure adequate air supply, and to avoid overheating do not place the unit near radiators etc.

- ◆ Blown fuses must be replaced by fuses of the same type and rating! Please refer to the "Specifications" for details.



### Caution

- ◆ Before changing the fuse, switch off the device and pull the plug to avoid electric shock or damage to the device.

The power connection is made by using the enclosed cable and the amplifier's standard IEC receptacle. It meets all of the international safety certification requirements.

- ◆ Please make sure that all units have a proper earth connection. For your own safety, never remove or disable the earth conductor from the unit or of the AC power cord. The unit must always be connected to the mains outlet with a protective grounding connection.
- ◆ Extreme output volumes may damage your hearing and/or your loudspeakers. Turn down all volume and level controls before you switch on the unit. Always set the volume to an appropriate level.

### IMPORTANT NOTES CONCERNING INSTALLATION

- ◆ The sound quality may diminish within the range of powerful broadcasting stations and high-frequency sources. Increase the distance between the transmitter and the device and use shielded cables for all connections.

#### 1.1.3 Online registration

Please remember to register your new BEHRINGER equipment right after your purchase by visiting [www.behringer.com](http://www.behringer.com) (alternatively [www.behringer.de](http://www.behringer.de)) and read the terms and conditions of our warranty carefully. Should your BEHRINGER product malfunction, our goal is to have it repaired as quickly as possible. To arrange for warranty service, please contact the retailer from whom the equipment was purchased. Should your BEHRINGER dealer not be located in your vicinity, you may directly contact one of our subsidiaries. Corresponding contact information is included in the original equipment packaging (Global Contact Information/European Contact Information). Should your country not be listed, please contact the distributor nearest you. A list of distributors can be found in the support area of our website ([www.behringer.com](http://www.behringer.com)). Registering your purchase and equipment with us helps us process your repair claims quicker and more efficiently. Thank you for your cooperation!

## 1.2 The user manual

The user manual is designed to give you both an overview of the controls, as well as detailed information on how to use them. In order to help you understand the links between the controls, we have arranged them in groups according to their function. If you need to know more about specific issues, please visit our website at <http://www.behringer.com>. Additional information and explanations about various music industry/audio technology terminology can be found on individual product pages as well as in the glossary.

## 2. Quick start

### 2.1 Hook-up example (inputs and inserts)

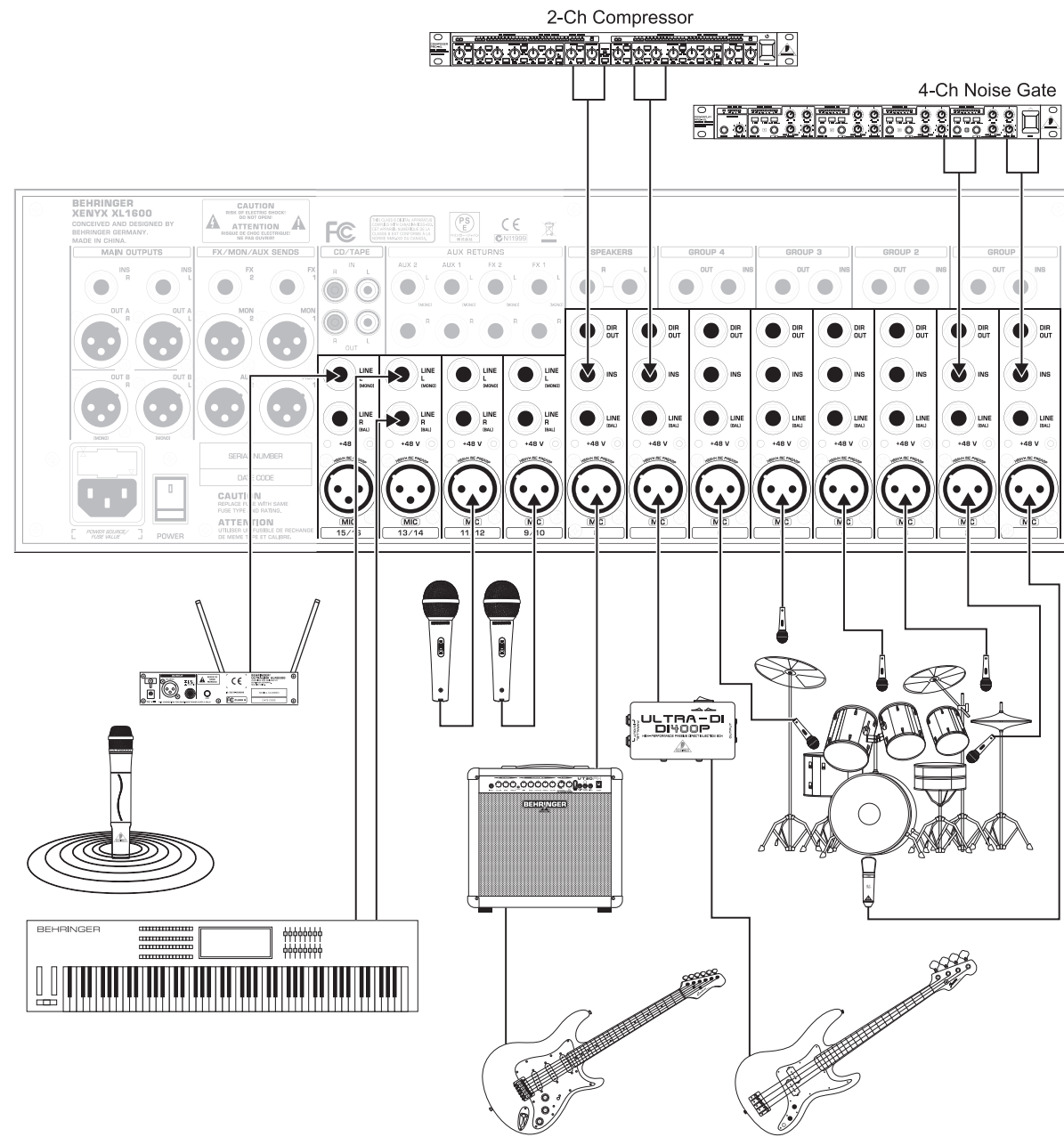

Fig. 2.1: Input wiring

### 2.2 Hook-up example (outputs)

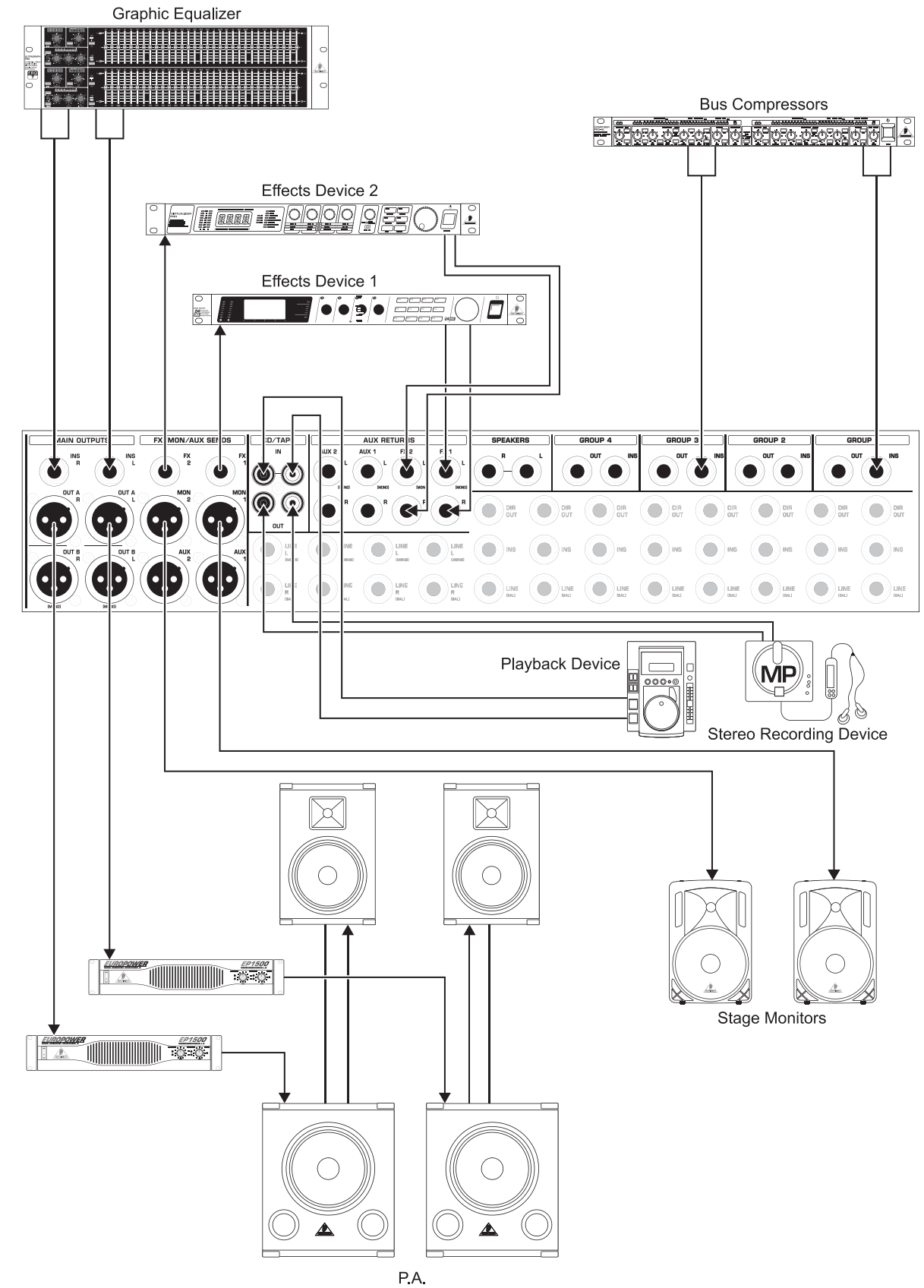

Fig. 2.2: Output wiring

### 3. Installation

#### 3.1 Audio connectors

The 1/4" inputs and outputs of the BEHRINGER XENYX mixer are unbalanced mono TS connectors except for the balanced Line inputs on the mono and stereo channels as well as the Main Out connectors. Of course, you can use the mixer with balanced as well as unbalanced 1/4" connectors. The CD/TAPE inputs and outputs are stereo RCA connectors.

♦ **Make sure that only competent people install your mixer. They must be sufficiently grounded during and after the installation process. Otherwise, electrostatic discharges may negatively affect the operating characteristics of your equipment.**

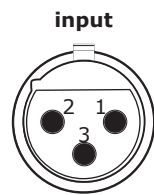

- 1 = ground/shield
- 2 = hot (+ve)
- 3 = cold (-ve)

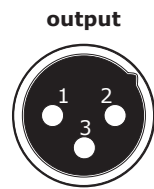

For unbalanced use, pin 1 and pin 3 have to be bridged

#### Balanced use with XLR connectors

Fig. 3.1: XLR connector

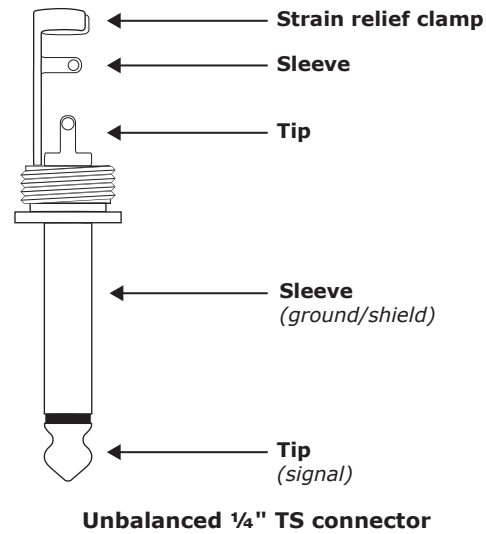
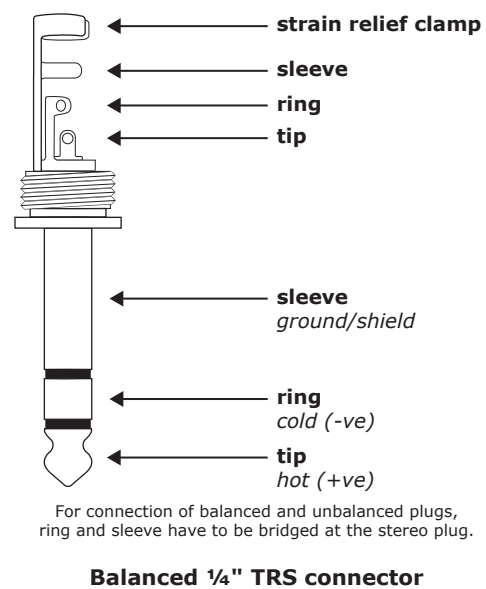
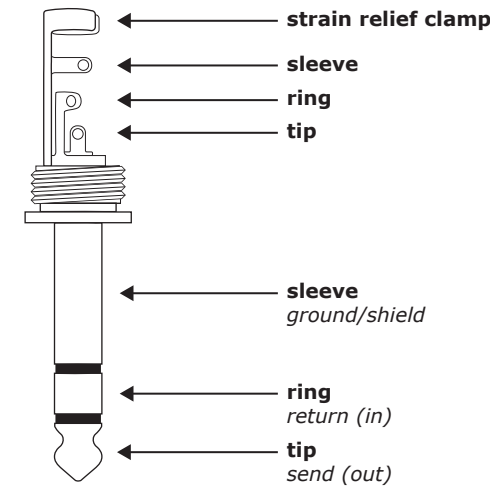

Fig. 3.2: 1/4" TRS connector



For connection of balanced and unbalanced plugs, ring and sleeve have to be bridged at the stereo plug.

Fig. 3.3: 1/4" TS connector



#### Insert send return 1/4" TRS connector

Fig. 3.4: Insert send/return stereo plug

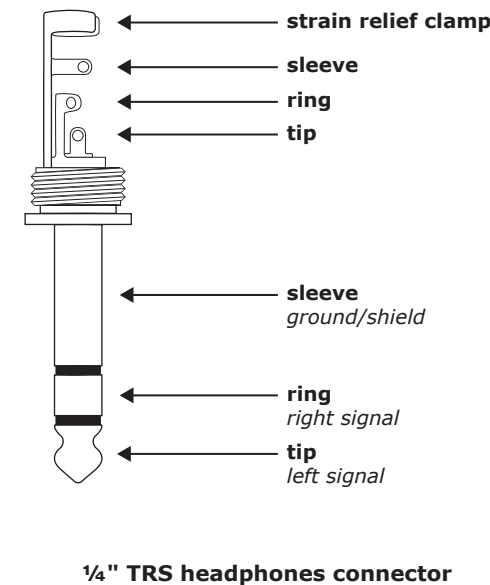

Fig. 3.5: 1/4" headphones connector

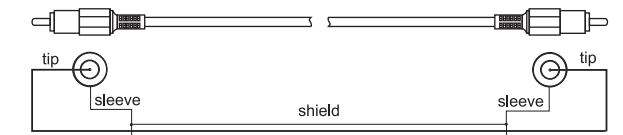
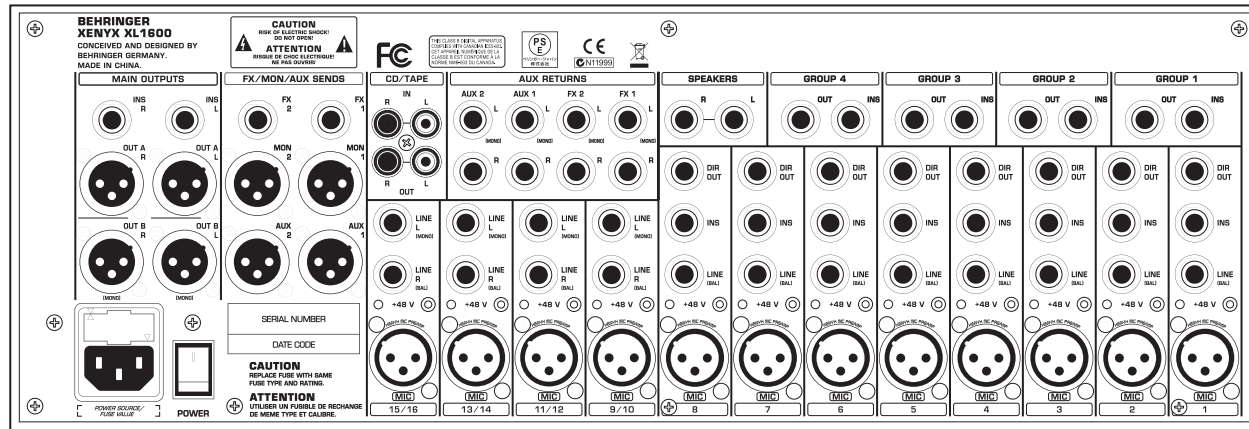

Fig. 3.6: RCA cable



## 4. Connectors

Let's begin with the rear panel where the majority of inputs and outputs are located.



### 4.1 Power supply

#### IEC receptacle

The mains connection is a standard IEC re-ceptacle. An appropriate power cord is supplied with the unit.

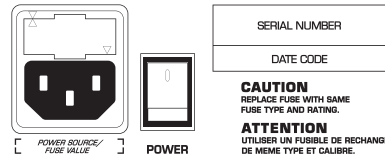

#### FUSE HOLDER

Before connecting the unit to the mains, ensure that the voltage setting matches your local voltage. Blown fuses should only be replaced by fuses of the same type and rating. Please also read the information given in chapter "Specifications."

#### POWER

Use the POWER switch to turn on the mixing console. The POWER switch should always be in the "Off" position when you are about to connect your unit to the mains. To disconnect the unit from the mains, pull out the main cord plug. When installing the product, ensure that the plug is easily accessible. If mounting in a rack, ensure that the mains can be easily disconnected by a plug pull or by an all-pole disconnect switch on or near the rack.

- ♦ **Please note: The POWER switch does not fully disconnect the unit from the mains. To disconnect the unit from the mains, pull out the main cord plug or appliance coupler. When installing the product, ensure the plug or appliance coupler is readily operable. Unplug the power cord when the unit is not used for prolonged periods of time.**

#### SERIAL NUMBER

This is the serial number of the mixing console.

### 4.2 Mono inputs

#### MIC

The balanced XLR input connects to microphones, DI boxes and multicores. (Multicores are cables that have multiple cores and which run from the so-called stagebox to the mixer.)

- ♦ **Connect the microphone and mute all mixer outputs before turning on the phantom power to avoid noise when the microphone is turned on. Please wait for about one minute when switching on the mic until the voltage is stable. Only then turn on the input amplification.**

- ♦ **Caution! Never use unbalanced XLR connectors (pins 1 and 3 interconnected) on the MIC input jacks, if you want to use phantom power.**

#### +48 V

Phantom power is used for operating a capacitor microphone. A control LED lights up next to the switch when the phantom power supply is active. Additional control LEDs are located in each Trim section of the mixer's channels. As a rule, dynamic microphones can still be used with phantom power, provided they are wired in a balanced configuration. In case of doubt, contact the microphone manufacturer!

#### LINE

This is a 1/4" jack connector which connects to line-level signal sources (for example, keyboards, CD players and wireless microphone receivers). The input is balanced (TRS connector) but can also be used with unbalanced connectors (TS connector).

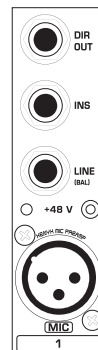

### INSERT

The INS(ert) connector (1/4" stereo jack connector) is used to connect to external signal processors. Here you can hook up a compressor, noise gate or equalizer to process the signal of a single channel. The insert jack is placed before the fader, EQ and aux send. Please use an insert cable to connect to the insert point.

### DIRECT OUT

This 1/4" mono jack connector is a direct output which taps the signal after the channel fader to route it to a multi-track recorder, for example. By modifying the circuit board in the unit, the signal can also be tapped pre-fader (see chapter 6).

### 4.3 Stereo inputs

#### LINE L (MONO), LINE R

The stereo channels consist of two line inputs (1/4" jacks), one for the left and one for the right channel. The inputs are balanced (TRS connectors), but it is also possible to connect to unbalanced plugs (TS connectors). These channels can also be used as mono channels by connecting to the jack labeled "L" (left).



#### MIC

The stereo channels also consist of XLR inputs for connecting to microphones DI boxes and multicores.

#### +48 V

This is the phantom power for operating capacitor microphones along with the control LED located next to the switch and in the Trim section of the stereo channels.

### 4.4 Main mix outputs

#### OUT A

The OUT A outputs are balanced XLR connectors with a nominal operating level of +4 dBu and provide the main mix signal.

#### OUT B

The OUT B outputs provide the MAIN B signal the volume level of which can be controlled.

#### INSERT

Like the channel inserts, the INS(ert) connectors can be used to hook up a dynamics processor or equalizer for further processing of the mix signal on OUT A.

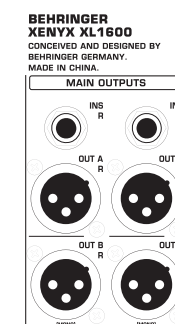

### 4.5 Subgroup connectors

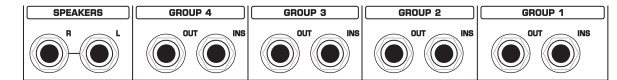

#### GROUP OUT 1 - 4

These four GROUP OUTS 1 – 4 carry the signals of the individual subgroups. For multi-tracking connect the outputs to the inputs of a multi-track recorder.

#### INSERT

Each subgroup has an insert jack which is labeled INS. Here you can connect to a noise gate, compressor or equalizer to process the subgroup signal as a whole. For example, route your background vocalists to one subgroup bus and then use a compressor to bring the vocals closer together. This makes it sound more like a choir rather than a group of individual soloists. The insert point is placed before the group fader, allowing the dynamics processors (noise gate, compressor, etc.) to be optimally used and not affected by changes in volume level of the group fader. Please use an insert cable to connect to the insert point.

#### SPEAKERS

The SPEAKERS outputs provide the same signal as the headphone outputs. Use these outputs to hook up monitor speakers. This is helpful when the mixing console is not located close to the performance but in a separate room, such as a TV control room. It is also possible to hook up a stage monitor, ideally one identical to the monitors being used on stage, to listen in on the sound as perceived from the stage monitors.

### 4.6 CD/tape connectors

#### IN

The CD/TAPE input connectors are used to hook up CD players, tape decks or other line-level sources.

#### OUT

The CD/TAPE output connectors provide the stereo main mix signal to a tape deck or DAT recorder to record your mix. The signal is taken pre-fader so that it will not be influenced by the fader positions.

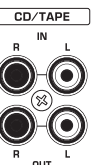

### 4.7 FX/Mon/Aux sends

#### FX 1 and 2

The FX outputs 1 and 2 provide the signals of the effects buses 1 and 2. These signals may be sent to external effects processors and are routed back over the AUX-RETURN inputs or separate input channels, for example.

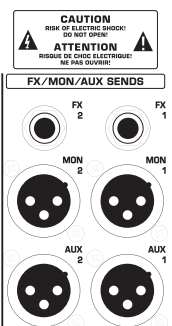

## MON 1 and 2

The monitor outputs 1 and 2 provide the signals of the monitor buses. These signals may be sent to stage loudspeakers. To prevent interference due to the long cables being used between stage and mixing console, the outputs are balanced XLR connectors. What's more, you have the right connectors when working with multicores.

## AUX 1 and 2

The AUX outputs 1 and 2 provide the signals of the AUX buses 1 and 2. You can switch these buses pre-fader and post-fader so that they may be used for effects as well as for monitor applications.

## 4.8 Aux returns

### AUX RETURN

The stereo AUX inputs 1 and 2 let you connect the mixer to additional equipment (players, effects processors, submixers, etc.). The signal is sent to the signal sum.

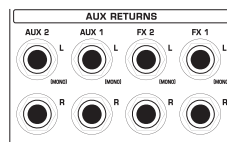

### FX RETURN

The stereo FX RETURN connectors 1 and 2 are linked to the outputs of external effects processors. Depending on the routing, the signals are sent to the subgroup or the main mix bus.

## 4.9 Light and headphone connectors

### LAMPS

The LAMPS plugs are for connecting gooseneck lamps with BNC connectors. The power supply is 12 V - and the total connection load is 5 Watts a lamp.

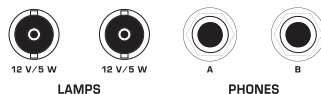

### PHONES

The PHONES outputs (1/4" stereo jacks) let you plug in your headphones.

## 5. Control elements

This chapter describes the various control elements of your mixing console. Each control and switch is explained in full detail.

### 5.1 Mono channels

#### +48 V

This control LED lights up as long as the phantom power is switched on. The switch is found on the rear panel of the unit.

#### Trim

The TRIM control adjusts the input gain.

- Be sure to set this control fully counter-clockwise before you connect or disconnect a signal source to or from one of the inputs.

The dial offers 2 different value ranges. The first value range between 0 and +60 refers to the microphone input, indicating the degree of amplification applied to the input's signal. The second value range between -20 and +40 dB refers to the amplification of the line input. When centered (at 12 o'clock), the line signals are neither boosted nor cut.

#### 80 Hz

Press the 80 Hz switch to activate the high-pass filter which blends out low-frequency noise (-3 dB at 80 Hz, 18 dB/octave).

#### Equalization

The mono input channels provide 4-band equalization with 2 semi-parametric mids. You can boost or cut the bands up to 15 dB. When in center position (0 dB), the equalizer has a flat response.

#### HIGH

The high-frequency range is processed with a shelving filter above 12 kHz.

#### HIGH MID

A semi-parametric peak filter processes the upper mid range between 400 Hz and 8 kHz. The FREQ control selects the frequency which is boosted or cut by using the HIGH MID control.

#### LOW MID

A second semi-parametric peak filter processes the upper mid range. The FREQ control selects the frequency which is boosted or cut by using the HIGH MID control.

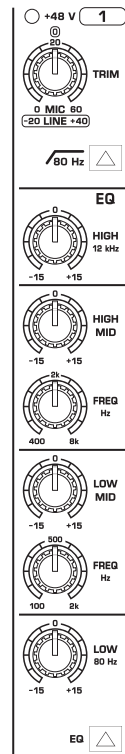

## LOW

The low-frequency range is processed with a shelving filter below 80 Hz.

## EQ

The EQ push-button switch activates the equalizer. Toggle the EQ to give you a quick comparison between unprocessed and processed signal.

### 5.1.1 FX, MON, AUX send paths

The send paths FX, MON and AUX allow you to tap the signals of one or more channels and route them to other outputs. This way you can create individual mixes for effects (FX) and musicians performing on stage (MON). Using the FX/MON/AUX send outputs, the mix is fed to the stage loudspeakers and effects units.

#### FX 1 and FX 2

The FX buses are used as send paths to external effects units. The signal is usually tapped after the channel fader and therefore is affected by the position of the channel fader. The FX control adjusts the volume level of the channel signal to the effects unit.

#### PRE

Press the PRE switch to change the routing of both effects paths from "post-fader" to "pre-fader." This way the volume level of the effects signal is not affected by the channel fader. Both the FX control on the channel and the corresponding Master FX SEND control need to be fully turned up as well. Connect the FX Send output to the input of the effects unit. The effects signal is routed back through the FX Returns found in the master section.

#### Monitor 1 and 2:

The monitor buses are used as send paths to stage monitors. The monitor sends are hardwired pre-fader. This means the volume level of the monitor mix is not affected when using the channel fader. The MON control adjusts the volume level of the channel signal in the monitor buses.

#### AUX

The aux buses are used as additional, flexible send paths for various applications. The AUX control adjusts the volume level of the channel signal in the aux buses. The sum of all aux signals is determined by the corresponding AUX SEND control found in the main section. The signals can be routed from the corresponding AUX SEND outputs. Both the aux send paths can be amplified up to +15 dB and are pre-fader and post-fader switchable in the main section.

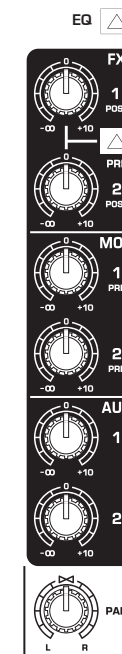

## Pre-fader or post-fader:

For most applications using external effects signals, the aux send path should be switched to post-fader so that the effects volume level in a channel is affected by the position of the channel fader. If not, the effects signal would be audible even with a pulled down fader. For monitoring applications, the aux send paths are usually switched to pre-fader and therefore are not affected by the channel fader. To offer you the utmost flexibility, the FX buses can be switched to pre-fader in each channel. What's more, you may switch the AUX buses in the main section between pre-fader and post-fader. This gives you a maximum of 6 pre-fader buses or, alternatively, 4 post-fader plus 2 pre-fader buses.

### 5.1.2 Channel fader, pan control, mute control, etc.

#### PAN

The PAN control determines the position of the channel signal in the stereo mix as well as the subgroup to which the channel signal is routed.

#### MUTE

The MUTE switch mutes the channel. This means that the channel signal has been removed from the main mix and subgroups. At the same time the FX, monitor and aux paths of the respective channel are muted as well. The corresponding MUTE LED indicates that the channel has been muted.

#### SOLO

Use the solo function to listen in on a channel. Press the channel's SOLO switch to hear the signal on your headphones. Simultaneously, the monitor meter 1/2 switches to the solo signal, allowing you to level the signal correctly (see chapter X). The signal to be listened in on is tapped either before (PFL, mono) or behind (AFL, stereo) the channel fader and the pan control (depending on the state of the PFL/AFL switch). The corresponding LED lights up when the solo function is activated.

#### CLIP

The CLIP LED lights up as soon as the channel's level is too high. In this case, reduce the channel's input amplification with the TRIM control.

#### SIG

The SIG LED lights up when a channel's signal is higher than -20 dB. The LED is not affected by the fader. The signals are indicated even when the fader is pulled down and the channel is muted.

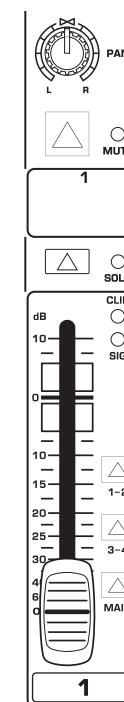



### 1 MON 2

The monitor meters indicate the levels of the monitor buses 1 and 2. In solo mode (SOLO LED lights up) the PFL signal (mono, only left meter) or the AFL signal (stereo, left and right meter) are shown. This depends on the state of the PFL and AFL switch in the solo section.

### SOLO

When a SOLO switch is pressed on the mixing console, not only the corresponding LED lights up, but also the global SOLO LED. This way you can keep a cool head when mixing live and don't have to check the whole console to see that one SOLO switch is active. Simultaneously this LED indicates that the monitor meters are in solo mode.

### MAIN

The high-precision level meter accurately indicates the output signal level (MAIN OUT A).

### 5.5 Subgroups

The XENYX provides 4 subgroups which allow you to feed multiple channels to mono or stereo mixdowns. Their volume level can be adjusted using the subgroup faders. For example, create a subgroup with all vocal channels and adjust the volume using the subgroup fader. This way you can keep track and, at the same time, can process the signal with a compressor via the subgroup insert. Additionally, you can also use the subgroup outputs as sends for a multitrack recorder.

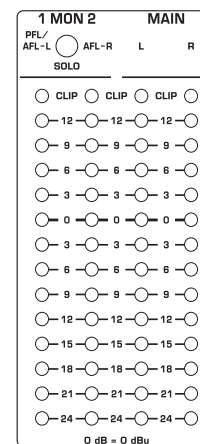
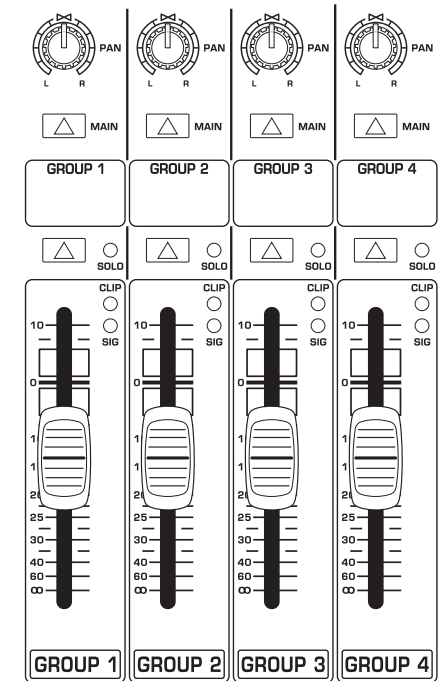

### 1-2, 3-4, MAIN

The routing switch feeds the signal to the respective subgroup or the main mix or both. Please note that when using the routing switch to route a stereo signal to the subgroups the balance control needs to be centered so that the signal is routed to two groups and remains in stereo.

### 5.3 Main section

#### 5.3.1 MAIN A section

#### BAL(ANCE)

The BAL(ANCE) control adjusts the mix of the left and right output signal before both signals are routed to the MAIN A output. This way the left and right volume level of the mixer sum can individually be adjusted if necessary.

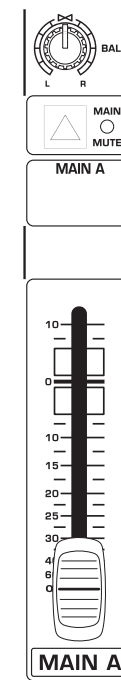

#### MAIN MUTE

When the MAIN MUTE switch is pressed, all input channels are muted. The MUTE LED lights up when the MUTE switch is pressed. Only the CD/TAPE signal will be routed to the main mix. In this way, you can prevent the microphones from picking up unwanted sounds or noise that would interfere with CD playback during a break. The main mix and channel faders can remain in their normal positions while playing back music from CD (using the CD/TAPE inputs, so you don't lose your mix.

#### MAIN A

Use this high-precision MAIN fader to control the output level of the main mix.

#### MAIN B

Depending on the settings of the MAIN B section, the level of the Main B output is affected by the MAIN A fader.

### 5.4 Level meters

Four high-resolution LED meters indicate the levels of the monitor buses' and mixer sum's output signals. As soon as you have pressed the solo switch on the mixing console, the monitor LED meter automatically shows the solo signal. The master signal is always indicated.

### Fader

The channel fader adjusts the level of the channel signal as part of the main mix (or submix).

### 1-2, 3-4, MIX

The routing switch routes the signal to the respective subgroup or the main mix or both. The XENYX features 4 subgroups. The PAN control determines the group to which the signal is routed (fully left: Sub 1 or 3, fully right: Sub 2 or 4).

### 5.2 Stereo channels

#### +48 V

This control LED lights up when the phantom power is activated. The switch is located on the rear panel of the unit.

#### MIC TRIM

The MIC TRIM control adjusts amplification of the microphone input. The amplification ranges between 0 and +60 dB.

Be sure to set this control fully counter-clockwise before you connect or disconnect a signal source to or from one of the inputs.

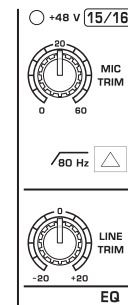

#### 80 Hz

Press the 80 Hz switch to activate the high-pass filter which blends out low-frequency noise (-3 dB at 80 Hz, 18 dB/octave).

#### LINE TRIM

The LINE TRIM control adjusts the amplification of the LINE input, ranging between -20 and +20 dB. When centered (at 12 o'clock), the line signal is neither boosted nor cut.

### 5.2.1 Equalizer stereo channels

The stereo channels provide 4-band equalization. Each frequency band can be boosted and cut up to 15 dB and has a flat response when the controls are in center position.

#### HIGH

The HIGH control of the EQ section adjusts the high-frequency range of the respective channel. This is a shelving filter which boosts and cuts the frequencies above 12 kHz.

#### HIGH MID

The HIGH MID control adjusts the mid frequency range. This is a peak filter which boosts and cuts the frequencies centered at 3 kHz.

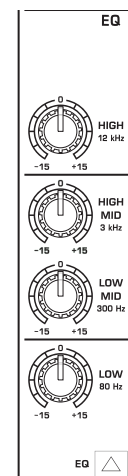

### LOW MID

The LOW MID control adjusts the mid frequency range. This is a peak filter which boosts and cuts the frequencies centered at 300 Hz.

### LOW

The LOW control adjusts the low-frequency range. This is a shelving filter which boosts and cuts the frequencies below 80 Hz.

### EQ

The EQ push-button switch activates the equalizer. Toggle the EQ to give you a quick comparison between unprocessed and processed signal.

### 5.2.2 Stereo channel FX/MON/AUX send paths

The aux and FX paths of the stereo channels work in principle the same way as the mono channels. Since the aux buses are mono, the stereo signal needs to be converted to a mono signal before being routed to these buses.

### 5.2.3 Channel fader, pan control, mute switch, etc.

#### BAL(ANCE)

The BAL(ANCE) control has the same function as the PAN control on the mono channels. It determines the relative volume of the left and right input signals before they are routed to the stereo main mix bus (or to two subgroups).

#### MUTE

Use the MUTE switch to mute the channel signal. The MUTE LED is illuminated when the channel is muted.

#### SOLO

Press the SOLO switch to hear the signal on your headphones and simultaneously see it on the monitor display 1/2). The corresponding LED lights up when the solo function is activated.

#### CLIP

The CLIP LED lights up as soon as the channel's level is too high. In this case, turn the TRIM control to reduce the channel's input amplification until the LED goes out.

#### SIG

The SIG LED lights up when a channel's signal is higher than -20 dB. The LED is not affected by the fader. The signals are indicated even when the fader is pulled down and the channel is muted.

#### Fader

The channel fader governs the level of the channel signal as part of the main mix (or submix)

**PAN**

The PAN control adjusts the position within the stereo image.

**MAIN**

The MAIN switch routes the subgroup signal to the main mix. With the PAN control you can adjust the signal to the left side of the stereo image (PAN turned fully left), to the right side of the stereo image (PAN turned fully right) or to both sides (PAN in center position) of the stereo main mix. For example, when creating a stereo submix with the subgroups 1 and 2, group 1 should be adjusted to the left and group 2 to the right side of the main mix in order to maintain a balanced stereo image. In case you have created a mono submix with only one subgroup, be sure to center the PAN control so that the signal is not only heard on one side.

**SOLO**

The SOLO switch routes the subgroup signal to the AFL bus (Solo In Place) or PFL bus (Pre Fader Listen), so that you can monitor the subgroup signal without affecting the main or sub output signals. The signal to be monitored is taken either pre (PFL, mono) or post-subgroup fader (Solo, stereo), depending on the position of the SOLO/PFL switch. The SOLO LED illuminates when the SOLO switch is pressed.

**CLIP**

The CLIP LED lights up as soon as the subgroup signal's level is too high. In this case, pull down the channels' faders routed to this group.

**SIG**

The SIG LED lights up when a signal is routed to the subgroup whose level is higher than -20 dB.

- ♦ **The signal and clip LEDs are not affected by the fader. The signals are indicated even when the subgroup fader is pulled down.**

**Fader**

The subgroup faders adjust the volume level of the subgroup signal at the subgroup output. If the MAIN switch is pressed, you can also adjust the subgroup's volume level in the main mix.

**5.6 Further functions of the master section****5.6.1 Talkback**

The talkback function of the XENYX allows you to communicate with people on stage. The talkback signal can be routed to the different bus outputs.

**MIC**

Here you can plug in the microphone for talkback use.

**LEVEL**

The LEVEL control adjusts the volume level of the talkback signal.

**MON, AUX, GROUP, MAIN**

These push-button switches (MON, AUX, GROUP and MAIN) determine to which outputs and buses the talkback signal is to be routed. Then, turn on the talkback microphone. Press and hold down the push-button switch while speaking into the microphone.

**5.6.2 SOLO****SOLO LEVEL**

The SOLO LEVEL control adjusts the volume level of all solo signals routed to the headphone and loudspeaker outputs.

**PFL/AFL**

Press the PFL/AFL switch to change the solo functionality from PFL mono (pre-fader listen) to AFL stereo. The LED next to the switch indicates the selected state. In PFL mode, the signal is tapped before the fader when pressing the solo switch. In AFL mode, the signal is tapped behind the fader and in stereo for a correct positioning within the stereo image. If you adjust the signal's level with the TRIM control, select the PFL mode so that the displayed level is not affected by the channel fader.

**5.6.3 CD/TAPE****LEVEL**

The LEVEL control adjusts the signal in the main mix, for example, when connecting the CD/tape inputs to a CD player.

**MAIN**

Press the MAIN switch to route the CD signal to the main output. The CD signal remains audible even when the MAIN MUTE switch is pressed. This allows you to play music during performance breaks.

**5.6.4 PHONES/SPEAKER section**

The PHONES A/B control adjusts the volume level of the headphone output.

- ♦ **IMPORTANT! High volume levels may damage your hearing and/or your headphones/loudspeakers. To avoid switch-on/off thumps from the console and any downstream devices, always make sure that the power amp(s) or active speaker(s) are the last components that are switched on and the first to be switched off. Always make sure that the appropriate volume is set.**

**SPKR**

The Speaker control adjusts the volume level of the SPEAKERS outputs.

**SOURCE**

The SOURCE push-button switch selects the signal source for the headphone and loudspeaker outputs (main or CD/TAPE signal). Pressing a solo switch routes the solo signal to these outputs and is not affected by the SOURCE push-button switch.

**MAIN B section**

The mixer sum can also be routed to the MAIN B output which may be connected to a separate power amplifier. This way the sum can be sent to multiple zones and various loudspeaker groups (for example, center clusters and front fills). One may also want to connect a stereo recording system for live recording.

**LEVEL**

The LEVEL control adjusts the volume level of the signal routed to the MAIN B output.

**STEREO/MONO**

The STEREO/MONO switch changes the Main B signal from mono to stereo depending on the situation. For example, a mono signal is usually used for a center cluster.

**PRE/POST**

The PRE/POST switch is used to determine whether the signal is tapped in front or behind the MAIN A fader.

**5.7 FX master section**

This section has additional inputs for signals which do not require further signal processing. Ideally, use them for signals returning from external effects units. This is why these inputs are referred to as FX returns. It is possible to route the effect signals to the monitors and subgroups. This way the stereo channels can be used for additional stereo signals, such as keyboards, etc., and not for effects units' signals which require functions like fader, routing, solo and mute.

**FX SEND**

This is the master FX SEND control for adjusting the volume of all FX send signals at the corresponding FX send jacks and at the inputs of the built-in effects processor. Use it to control the master signal of all FX 1/FX 2 signals from the input channels. When neither of the FX SEND controls is turned up, the effects processor will not receive a signal.

**MON**

Use the MON controls to add an effect signal to the monitor buses 1 and 2. For this application, the effects unit needs a signal: turn up the respective master FX SEND control and the FX send controls on the channel strips (34) and pull up the channel faders.

**1-2, 3-4**

These selector switches route the effect signal to the main mix or to the subgroups 1-2 or 3-4. For example, if you create a subgroup for a choir, you need to feed the effect, which processes the vocal signal, to the same subgroup so that all signals can be adjusted equally. In this case it doesn't matter that the FX sends are routed post-fader as long as the choir's volume level is adjusted with the subgroup fader. Otherwise, the effect signal is perceived as unaffected in the main mix.

**MUTE**

The MUTE switch mutes the effect return path. Use this function to deactivate the reverb effect of a vocalist who makes announcements between songs. The corresponding MUTE LED indicates that the channel is muted.

**SOLO**

Press the SOLO switch to listen in on the effect signal on the head-phones/speakers as well as see it on the monitor meter 1/2. The corresponding LED lights up when the solo function is activated.

**FX RETURN**

The FX return fader adjusts the volume level of the returned effect signal in the main mix and subgroups (this depends on the routing switch you have pressed).



## 5.8 Monitor send section

The monitor send section merges the monitor signals of all channels. Then the mix is sent to the monitor outputs. The monitor fader provides precise adjustment and optical control of the monitor output signals.

### SEND

The SEND faders control the output level of the monitor buses. Each fader is 60 mm long and features 10 dB headroom.

### MUTE

Each monitor send has a MUTE switch and MUTE LED.

### SOLO

For acoustic control of the stage sound, use the SOLO switch to feed the monitor signal to the headphone and speaker output. If you connect the speaker output to a monitor that is identical with the monitor speakers on stage, you can tell how the stage sound is perceived.

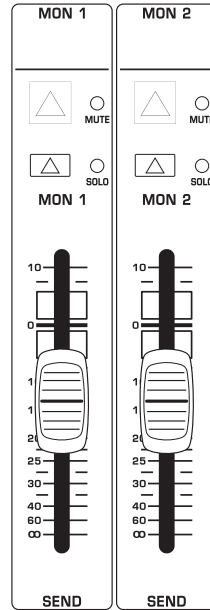

## 5.9 AUX master section

This section is split up in an aux send section (left side) and an aux return section (right side). The aux send paths 1 and 2 can individually be switched from pre-fader to post-fader depending on whether you want to use them as monitor or effect signal paths. As with all outputs, both aux master outputs feature 10 dB headroom as well as a MUTE and SOLO switch. In the aux return section, you can adjust the signals of the devices (CD player, effects unit, submixer, etc.) connected to the aux inputs which are then routed to the monitor buses and the main mix.

### PRE/POST

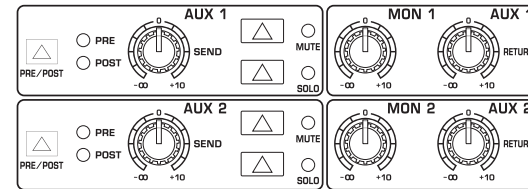

This is the global PRE/POST switch for the aux buses. For utmost flexibility, each AUX bus can individually be switched from pre-fader to post-fader.

### AUX SEND

The Master AUX SEND controls 1 and 2 adjust the signals' volume level of the respective aux send connector. This way you adjust the sum of the AUX 1 and AUX 2 signals on the input channels.

### MUTE

The MUTE switch mutes the aux outputs.

### SOLO

The aux send signals can individually be listened to using the SOLO function.

### MON

A signal sent from AUX RETURN can be added to the stage mix using the MON control.

### AUX RETURN

The AUX RETURN controls adjust the volume level of the aux return signals in the main mix.

## 6. Modifications

- ◆ These modifications require soldering. Attempt only if you are experienced in using an iron on PCBs. Otherwise, refer to qualified personnel. After modification the warranty becomes void.
- ◆ We wish to be absolutely clear that BEHRINGER cannot be held responsible after you start disassembling your XENYX. If you make much of your warranty privileges, think again.
- ◆ Links should not be threaded into the holes on the PCB, but are to be soldered to the tinned areas around the holes. Bend the links a little upwards.

### 6.1 Mon/Aux sends > post-EQ

Pre-fader switched monitor sends and aux sends are tapped off before the equalizer. Do you prefer post-EQ? What are you waiting for? You don't have to look far—the necessary information is found on the bottom side of the unit.

- ◆ Make sure to turn off the mixer and disconnect it from the mains before removing the cover.

- 1) Strip the PRE EQ lead.



- 2) Solder a POST EQ link into place.

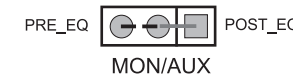

- 3) Make these modifications to as many channels as required (does it have to be all of them?).

### 6.2 Direct Out > pre-fader

If you prefer to use the Direct Out pre-fader than post-fader, the signal needs to be tapped off before the fader and not after the fader. To perform this modification, find the label "DIR-OUT" on the circuit board.

- ◆ Make sure to turn off the mixer and disconnect it from the mains before removing the cover.

- 1) Strip the POST FADER lead.



- 2) Solder a PRE FADER link into place.



- 3) Make these modifications to as many channels as required.

## 7. Specifications

### MONO INPUTS

#### Microphone inputs (XENYX Mic preamp)

Type	XLR connector, electronically balanced, discrete input circuit RF rejection filters
------	---

#### Mic E.I.N.1 (20 Hz - 20 kHz)

@ 0 $\Omega$ source resistance	-127 dB / 129.7 dB A-weighted
@ 50 $\Omega$ source resistance	-126 dB / 128.3 dB A-weighted
@ 150 $\Omega$ source resistance	-125 dB / 126.5 dB A-weighted

#### Frequency response

To Direct Out	<10 Hz - 50 kHz (-1 dB) <10 Hz - 100 kHz (-3 dB)
To Insert Send	<10 Hz - 90 kHz (-1 dB) <10 Hz - 170 kHz (-3 dB)
Gain range	0 dB to +60 dB Max. input level +24 dBu @ 0 dB Gain
Impedance	approx. 2.6 k $\Omega$ balanced
Signal-to-noise ratio	120 dB / 122 dB A-weighted (0 dBu In @ +22 dB Gain)
Distortion (THD+N)	typ. 0.0008 %

#### Line input

Type	¼" TRS jack, electronically balanced
Impedance	approx. 20 k $\Omega$ balanced, approx. 10 k $\Omega$ unbalanced
Gain range	-10 dB to +40 dB Max. input level +22 dBu @ 0 dB Gain

#### Channel inserts

Type	¼" TRS jack, unbalanced Max. input level +22 dBu
------	--

#### Channel direct outs

Type	¼" TRS jack, balanced
Impedance	75 $\Omega$ balanced
Max. input level	+22 dBu

#### Crosstalk<sup>2</sup>

Main fader closed	100 dB
Channel muted	90 dB
Channel fader muted	85 dB

#### Frequency response (Mic In → Main Out)

<20 Hz - 20 kHz	+0 dB / -1 dB
<10 Hz - 160 kHz	+0 dB / -3 dB

#### Stereo inputs

Type	2 x ¼" TRS jack, balanced
Impedance	approx. 20 k $\Omega$ balanced, 10 k $\Omega$ unbalanced
Gain range	-20 dB to +20 dB
Max. input level	+22 dBu @ 0 dB Gain

#### CD/Tape in

Type	RCA connector
Impedance	approx. 10 k $\Omega$
Max. input level	+22 dBu

### EQUALIZER

#### EQ mono channels

LOW	80 Hz / $\pm$ 15 dB
HIGH MID	100 Hz to 2 kHz / $\pm$ 15 d
BLOW MID	400 Hz to 8 kHz / $\pm$ 15 dB
HIGH	12 kHz / $\pm$ 15 d
BLOW CUT	80 Hz, 12 dB/oct.

#### EQ stereo channels

LOW	80 Hz / $\pm$ 15 d
BLOW MID	300 Hz / $\pm$ 15 dB
HIGH MID	3 kHz / $\pm$ 15 dB
HIGH	12 kHz / $\pm$ 15 dB

#### Channel inserts

Type	¼" TRS jack, unbalanced
Max. input level	+22 dBu

#### AUX/MON send

Type	XLR connector, electronically balanced
Impedance	approx. 75 $\Omega$
Max. output level	+22 dBu

#### FX send

Type	¼" TRS jack, balanced
Impedance	75 $\Omega$
Max. output level	+22 dBu

#### AUX/FX Returns

Type	¼" TRS jack, unbalanced
Impedance	approx. 20 k $\Omega$
Max. input level	+22 dBu

#### Subgroup outputs

Type	¼" TRS jack, unbalanced
Impedance	approx. 75 $\Omega$
Max. output level	+22 dBu

#### Group inserts

Type	¼" TRS jack, unbalanced
Max. output level	+22 dBu

#### Main outputs A/B

Type	XLR connector, electronically balanced
Impedance	approx. 240 $\Omega$ balanced, 120 $\Omega$ unbalanced
Max. output level	+25 dBu

#### Main Inserts

Type	¼" TRS jack, unbalanced
Max. input level	+22 dBu

#### Speakers

Type	¼" TRS jack, unbalanced
Impedance	75 $\Omega$
Max. output level	+22 dBu

#### Phones A/B output

Type	¼" TRS jack, unbalanced
Max. output level	+22 dBu / 600 $\Omega$

#### CD/Tape output

Type	RCA connector
Impedance	approx. 1 k $\Omega$
Max. output level	+15 dBu

#### Main mix system data<sup>3</sup> (Noise)

Main mix @ - $\infty$ , channel fader @ - $\infty$	-110 dB / -114 dB A-weighted
Main mix @ 0 dB, channel fader @ - $\infty$	-95 dB / -98 dB A-weighted
Main mix @ 0 dB, channel fader @ 0 dB	-92 dB / -95 dB A-weighted

#### Power supply

XL1600	Power consumption 60 W
XL2400	Power consumption 65 W
XL3200	Power consumption 70 W
Fuse	(100 - 240 V~, 50/60 Hz) T 2,0 A H 250 V
Mains connector	Standard IEC receptacle

#### Physical/weight

Dimensions (H x W x D)	
XL1600	7.1 in / 180 mm x 19.5 in / 495 mm x 21.3 in / 540 mm
XL2400	7.1 in / 180 mm x 27.8 in / 705 mm x 21.3 in / 540 mm
XL3200	7.1 in / 180 mm x 35.8 in / 910 mm x 21.3 in / 540 mm
Weight (net)	
XL1600	25.8 lb / 11.7 kg
XL2400	19.0 lb / 8.6 kg
XL3200	32.8 lb / 14.9 kg

1) Equivalent Input Noise

2) Measuring conditions: 1 kHz rel. to 0 dBu; 20 Hz - 20 kHz; line input; main output; unity gain

3) 20 Hz - 20 kHz; measured at main output. Channels 1 - 4 unity gain; EQ flat; all channels on main mix; channels 1/3 as far left as possible; channels 2/4 as far right as possible; reference = +6 dBu

BEHRINGER is constantly striving to maintain the highest professional standards. As a result of these efforts, modifications may be made from time to time to existing products without prior notice. Specifications and appearance may differ from those listed or illustrated.

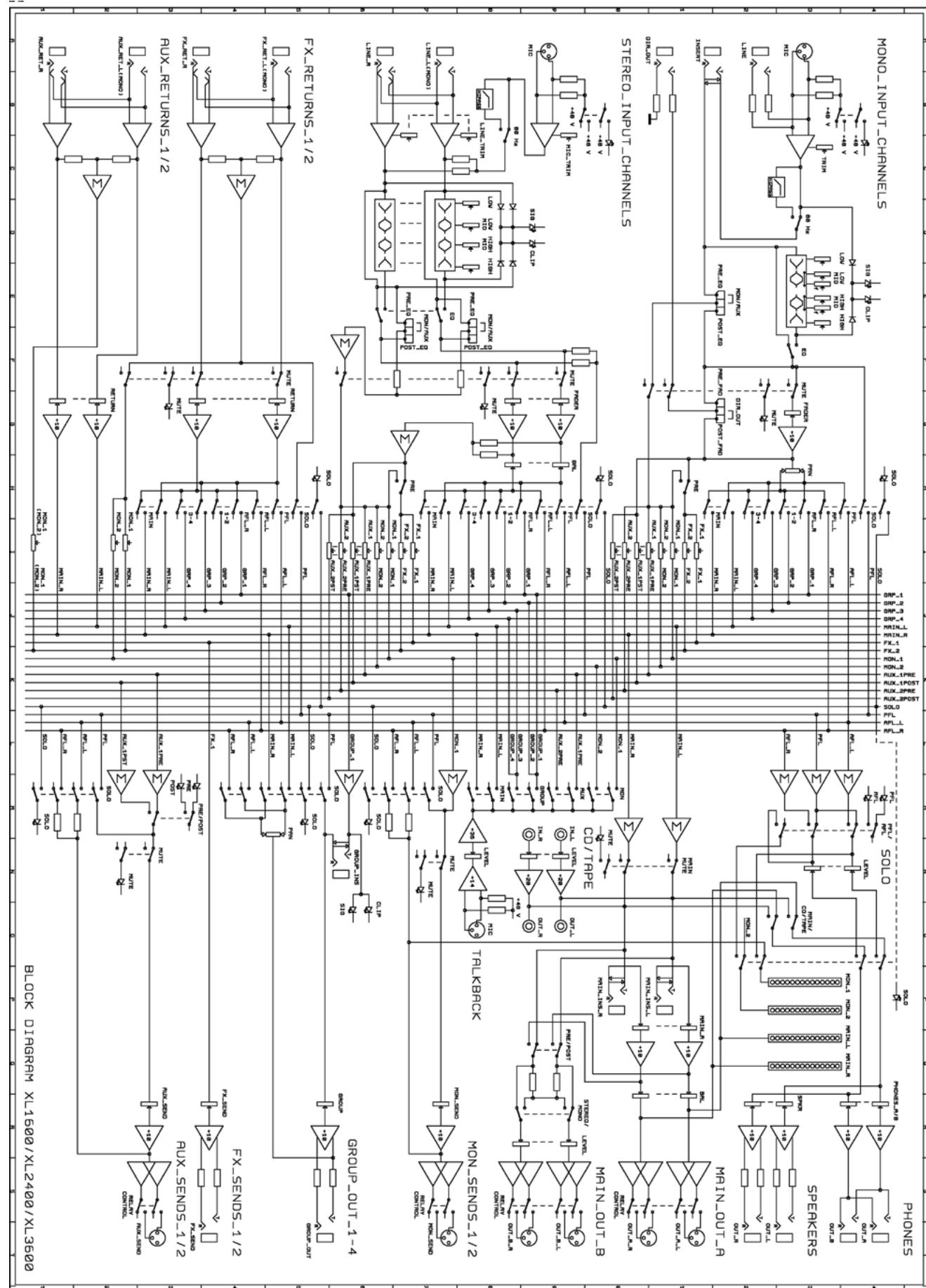

BLOCK DIAGRAM XL1600/XL2400/XL3200

# Limited Warranty

## § 1 Warranty

- 1 This limited warranty is valid only if you purchased the product from a BEHRINGER authorized dealer in the country of purchase. A list of authorized dealers can be found on BEHRINGER's website [www.behringer.com](http://www.behringer.com) under "Where to Buy", or you can contact the BEHRINGER office closest to you.
- 2 BEHRINGER\* warrants the mechanical and electronic components of this product to be free of defects in material and workmanship if used under normal operating conditions for a period of one (1) year from the original date of purchase (see the Limited Warranty terms in § 4 below), unless a longer minimum warranty period is mandated by applicable local laws. If the product shows any defects within the specified warranty period and that defect is not excluded under § 4, BEHRINGER shall, at its discretion, either replace or repair the product using suitable new or reconditioned product or parts. In case BEHRINGER decides to replace the entire product, this limited warranty shall apply to the replacement product for the remaining initial warranty period, i.e., one (1) year (or otherwise applicable minimum warranty period) from the date of purchase of the original product.
- 3 Upon validation of the warranty claim, the repaired or replacement product will be returned to the user freight prepaid by BEHRINGER.
- 4 Warranty claims other than those indicated above are expressly excluded.

PLEASE RETAIN YOUR SALES RECEIPT. IT IS YOUR PROOF OF PURCHASE COVERING YOUR LIMITED WARRANTY. THIS LIMITED WARRANTY IS VOID WITHOUT SUCH PROOF OF PURCHASE.

## § 2 Online registration

Please do remember to register your new BEHRINGER equipment right after your purchase at [www.behringer.com](http://www.behringer.com) under "Support" and kindly read the terms and conditions of our limited warranty carefully. Registering your purchase and equipment with us helps us process your repair claims quicker and more efficiently. Thank you for your cooperation!

## § 3 Return authorization number

- 1 To obtain warranty service, please contact the retailer from whom the equipment was purchased. Should your BEHRINGER dealer not be located in your vicinity, you may contact the BEHRINGER distributor for your country listed under "Support" at [www.behringer.com](http://www.behringer.com). If your country is not listed, please check if your problem can be dealt with by our "Online Support" which may also be found under "Support" at [www.behringer.com](http://www.behringer.com). Alternatively, please submit an online warranty claim at [www.behringer.com](http://www.behringer.com) BEFORE returning the product. All inquiries must be accompanied by a description of the problem and the serial number of the product. After verifying the product's warranty eligibility with the original sales receipt, BEHRINGER will then issue a Return Materials Authorization ("RMA") number.
- 2 Subsequently, the product must be returned in its original shipping carton, together with the return authorization number to the address indicated by BEHRINGER.
- 3 Shipments without freight prepaid will not be accepted.

## § 4 Warranty Exclusions

- 1 This limited warranty does not cover consumable parts including, but not limited to, fuses and batteries. Where applicable, BEHRINGER warrants the valves or meters contained in the product to be free from defects in material and workmanship for a period of ninety (90) days from date of purchase.

- 2 This limited warranty does not cover the product if it has been electronically or mechanically modified in any way. If the product needs to be modified or adapted in order to comply with applicable technical or safety standards on a national or local level, in any country which is not the country for which the product was originally developed and manufactured, this modification/adaptation shall not be considered a defect in materials or workmanship. This limited warranty does not cover any such modification/adaptation, regardless of whether it was carried out properly or not. Under the terms of this limited warranty, BEHRINGER shall not be held responsible for any cost resulting from such a modification/adaptation.
- 3 This limited warranty covers only the product hardware. It does not cover technical assistance for hardware or software usage and it does not cover any software products whether or not contained in the product. Any such software is provided "AS IS" unless expressly provided for in any enclosed software limited warranty.
- 4 This limited warranty is invalid if the factory-applied serial number has been altered or removed from the product.
- 5 Free inspections and maintenance/repair work are expressly excluded from this limited warranty, in particular, if caused by improper handling of the product by the user. This also applies to defects caused by normal wear and tear, in particular, of faders, crossfaders, potentiometers, keys/buttons, guitar strings, illuminants and similar parts.
- 6 Damage/defects caused by the following conditions are not covered by this limited warranty:
  - improper handling, neglect or failure to operate the unit in compliance with the instructions given in BEHRINGER user or service manuals;
  - connection or operation of the unit in any way that does not comply with the technical or safety regulations applicable in the country where the product is used;
  - damage/defects caused by acts of God/Nature (accident, fire, flood, etc) or any other condition that is beyond the control of BEHRINGER.
- 7 Any repair or opening of the unit carried out by unauthorized personnel (user included) will void the limited warranty.
- 8 If an inspection of the product by BEHRINGER shows that the defect in question is not covered by the limited warranty, the inspection costs are payable by the customer.
- 9 Products which do not meet the terms of this limited warranty will be repaired exclusively at the buyer's expense. BEHRINGER or its authorized service center will inform the buyer of any such circumstance. If the buyer fails to submit a written repair order within 6 weeks after notification, BEHRINGER will return the unit C.O.D. with a separate invoice for freight and packing. Such costs will also be invoiced separately when the buyer has sent in a written repair order.
- 10 Authorized BEHRINGER dealers do not sell new products directly in online auctions. Purchases made through an online auction are on a "buyer beware" basis. Online auction confirmations or sales receipts are not accepted for warranty verification and BEHRINGER will not repair or replace any product purchased through an online auction.

## § 5 Warranty transferability

This limited warranty is extended exclusively to the original buyer (customer of authorized retail dealer) and is not transferable to anyone who may subsequently purchase this product. No other person (retail dealer, etc.) shall be entitled to give any warranty promise on behalf of BEHRINGER.



## Legal Disclaimer

Technical specifications and appearance are subject to change without notice. The information contained herein is correct at the time of printing. BEHRINGER accepts no liability for any loss which may be suffered by any person who relies either wholly or in part upon any description, photograph or statement contained herein. Colors and specifications may vary slightly from product. BEHRINGER products are sold through authorized dealers only. Distributors and dealers are not agents of BEHRINGER and have absolutely no authority to bind BEHRINGER by any express or implied undertaking or representation. This manual is copyrighted. No part of this manual may be reproduced or transmitted in any form or by any means, electronic or mechanical, including photocopying and recording of any kind, for any purpose, without the express written permission of Red Chip Company Ltd.

ALL RIGHTS RESERVED.

© 2009 Red Chip Company Ltd.

Trident Chambers, Wickhams Cay, P.O. Box 146,  
Road Town, Tortola, British Virgin Islands

### § 6 Claim for damage

Subject only to the operation of mandatory applicable local laws, BEHRINGER shall have no liability to the buyer under this warranty for any consequential or indirect loss or damage of any kind. In no event shall the liability of BEHRINGER under this limited warranty exceed the invoiced value of the product.

### § 7 Limitation of liability

This limited warranty is the complete and exclusive warranty between you and BEHRINGER. It supersedes all other written or oral communications related to this product. BEHRINGER provides no other warranties for this product.

### § 8 Other warranty rights and national law

- 1 This limited warranty does not exclude or limit the buyer's statutory rights as a consumer in any way.
- 2 The limited warranty regulations mentioned herein are applicable unless they constitute an infringement of applicable mandatory local laws.
- 3 This warranty does not detract from the seller's obligations in regard to any lack of conformity of the product and any hidden defect.

### § 9 Amendment

Warranty service conditions are subject to change without notice. For the latest warranty terms and conditions and additional information regarding BEHRINGER's limited warranty, please see complete details online at [www.behringer.com](http://www.behringer.com).

\* BEHRINGER Macao Commercial Offshore Limited of Rue de Pequim No. 202-A, Macau Finance Centre 9/J, Macau, including all BEHRINGER group companies

## FEDERAL COMMUNICATIONS COMMISSION COMPLIANCE INFORMATION



Responsible party name: **BEHRINGER USA, Inc.**  
 Address: **18912 North Creek Parkway,  
 Suite 200 Bothell, WA 98011,  
 USA**  
 Phone/Fax No.: **Phone: +1 425 672 0816  
 Fax: +1 425 673 7647**

hereby declares that the product

**XENYX XL1600/XL2400/XL3200**

complies with the FCC rules as mentioned in the following paragraph:

This equipment has been tested and found to comply with the limits for a Class B digital device, pursuant to part 15 of the FCC Rules. These limits are designed to provide reasonable protection against harmful interference in a residential installation. This equipment generates, uses and can radiate radio frequency energy and, if not installed and used in accordance with the instructions, may cause harmful interference to radio communications. However, there is no guarantee that interference will not occur in a particular installation. If this equipment does cause harmful interference to radio or television reception, which can be determined by turning the equipment off and on, the user is encouraged to try to correct the interference by one or more of the following measures:

- Reorient or relocate the receiving antenna.
- Increase the separation between the equipment and receiver.
- Connect the equipment into an outlet on a circuit different from that to which the receiver is connected.
- Consult the dealer or an experienced radio/TV technician for help.

This device complies with Part 15 of the FCC rules. Operation is subject to the following two conditions:

- (1) this device may not cause harmful interference, and
- (2) this device must accept any interference received, including interference that may cause undesired operation.

### Important information:

Changes or modifications to the equipment not expressly approved by BEHRINGER USA can void the user's authority to use the equipment.



This manual is available in English, German, French, Spanish, Italian, Russian, Polish, Dutch, Finnish, Swedish, Danish, Portuguese, Greek, Japanese and Chinese. There may also be more current versions of this document. Download them by going to the appropriate product page at:

**[www.behringer.com](http://www.behringer.com)**